

siegling transilon
conveyor and processing belts

SIDEWALLS



Sidewalls

Article number	Thickness t [mm]	Height h [mm]	Width w [mm]	Pitch p [mm]	Shore A hardness	d_{\min} approx. [mm]**	Operating temperature permitted [°C]	Special feature
----------------	------------------	---------------	--------------	--------------	------------------	---------------------------	--------------------------------------	-----------------

PCV

FWG 5X40/P67-V60 green	882020	5	40	52	67	60	100	-10/+70	robust due to fabric reinforcement
FWG 5X60/P67-V60 green	882021	5	60	52	67	60	150	-10/+70	robust due to fabric reinforcement
FWG 5X80/P67-V60 green	882022	5	80	52	67	60	200	-10/+70	robust due to fabric reinforcement
FWG 5X40/P67-V60 white FDA	882023	5	40	52	67	60	100	-10/+70	robust due to fabric reinforcement
FWG 5X60/P67-V60 white FDA	882024	5	60	52	67	60	150	-10/+70	robust due to fabric reinforcement
FWG 5X80/P67-V60 white FDA	882025	5	80	52	67	60	200	-10/+70	robust due to fabric reinforcement
FW 5X33/P67-V60 green	881150	5	33	52	67	60	80	-10/+70	
FW 5X40/P67-V60 white FDA	880640	5	40	52	67	60	100	-10/+70	
FW 5X60/P67-V60 white FDA	880641	5	60	52	67	60	150	-10/+70	
FW 5X80/P67-V60 white FDA	880642	5	80	52	67	60	200	-10/+70	
FW 5X40/P67-V60 green	880646	5	40	52	67	60	100	-10/+70	
FW 5X60/P67-V60 green	880647	5	60	52	67	60	150	-10/+70	
FW 5X68/P67-V60 green	882127	5	68	52	67	60	175	-10/+70	
FW 5X80/P67-V60 green	880648	5	80	52	67	60	200	-10/+70	

Urethane

FW 2X40/P30-U87 blue-RAL5015 FDA	882221	2	40	36	30	87	80	-30/+80	smaller pitch for smaller end diameters
FW 2X40/P45-U87 blue-RAL5015 FDA	882220	2	40	36	45	87	100	-30/+80	
FW 2X30/P30-U87 green FDA	882035	2	30	36	30	87	50	-30/+80	smaller pitch for smaller end diameters
FW 2X40/P30-U87 green FDA	882036	2	40	36	30	87	80	-30/+80	smaller pitch for smaller end diameters
FW 2X30/P45-U87 green FDA	881246	2	30	36	45	87	80	-30/+80	
FW 2X40/P45-U87 green FDA	881247	2	40	36	45	87	100	-30/+80	
FW 2X60/P45-U87 green FDA	881248	2	60	36	45	87	150	-30/+80	
FW 2X30/P30-U87 white FDA	882037	2	30	36	30	87	50	-30/+80	smaller pitch for smaller end diameters
FW 2X40/P30-U87 white FDA	882038	2	40	36	30	87	80	-30/+80	smaller pitch for smaller end diameters
FW 2X30/P45-U87 white FDA	881243	2	30	36	45	87	80	-30/+80	
FW 2X40/P45-U87 white FDA	881244	2	40	36	45	87	100	-30/+80	
FW 2X60/P45-U87 white FDA	881245	2	60	36	45	87	150	-30/+80	

Polyester

FW 2X40/P45-E92 transparent FDA	881213	2	40	46	45	92	100	-10/+100	
FW 2X60/P45-E92 transparent FDA	881214	2	60	46	45	92	150	-10/+100	
FW 2X80/P67-E92 transparent FDA	881155	2	80	52	67	92	200	-10/+100	

Forbo Siegling's sidewall range focuses even more strongly on food safety and offers new options for more compact conveyor designs.

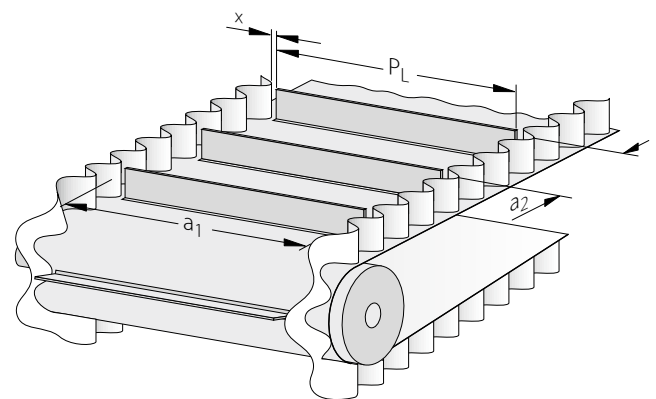

The properties

smaller pitch in PU sidewalls	▶	smaller drum diameters (50 mm for 30 mm high sidewalls, 80 mm for 40 mm high sidewalls)
light	▶	ideal for small conveyors
resistant to oil and grease	▶	for use in the food and pharmaceuticals industries

The advantages

Finished belt sizes available:

Length: 2600 to 60000 mm, Width: 200 to 1300 mm

Recommended splicing method:

Stepped overlap or stepped Z-splice

Inner distance between sidewalls:

$a_1 = 100$ to 1200 mm (for $a_1 < 150$ mm deviations in edge parallelism are possible)

Maximum profile length $P_{L\max}$: $P_{L\max} = a_1 - 2x$ (with $x = 2\frac{1}{3}$)

Sidewall amplitude tolerances: ± 1.0 mm

Manual splice tolerances:

Amplitude ± 3.0 mm; spacing distance ± 1.5 mm

Recommended conveyor belt types

Article number	Total thickness approx. [mm]	Weight approx. [kg/m ²]	Pull at 1% elongation (K _{1%} relaxed) [N/mm width]*	d _{min} approx. [mm]**	Operating temperature permitted [°C]	Special feature
----------------	------------------------------	-------------------------------------	---	---------------------------------	--------------------------------------	-----------------

PCV							
E 10/M V1/V10 green	900066	2.85	3.3	6	60	-10/+70	exceptionally robust
E 10/M V1/V10 MT white FDA	900092	2.85	3.3	6	60	-10/+70	exceptionally robust
E 12/2 U0/V7 green	900045	2.85	3.4	10	60	-10/+70	
E 12/2 U0/V20 MT-NA white FDA	900050	3.7	4.4	10	60	-10/+70	non-antistatic

Urethane							
E 6/2 U0/U2-M green FDA	906191	1.9	2	5.5	50	-30/+100	exceptionally laterally stiff
E 8/2 U0/U2 green FDA	900320	1.4	1.6	6.5	40/25 (Z)	-30/+100	
E 8/2 U0/U8 transparent FDA	900024	2	2.2	7.5	60	-30/+100	
NP 6698 (E 14/2 U0/U4-M MT white FDA)	906698	2.9	3	16	50	-30/+100	exceptionally laterally stiff, ideal for welding profiles and sidewalls
E 18/H U0/U2 MT white FDA	906420	1.75	1.75	21	20 ¹⁾	-30/+100	only limited suitability for swan neck conveyors

Polyester							
E 12/2 E0/E3 MT-TT transparent	900348	1.7	1.8	10.5	50 ¹⁾	-30/+100	
E 18/3 E0/E3 MT-TT transparent	900350	2.6	2.8	14	60	-30/+100	

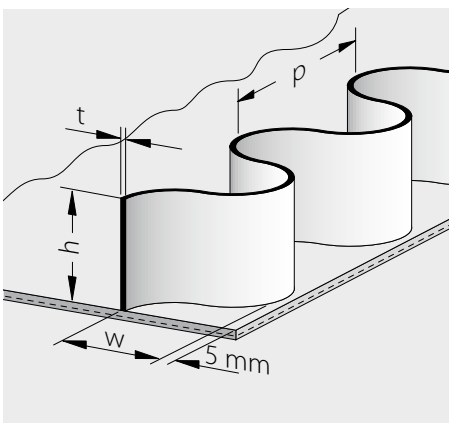

Type key

FWG 5 x 40 / P67 - V60 green

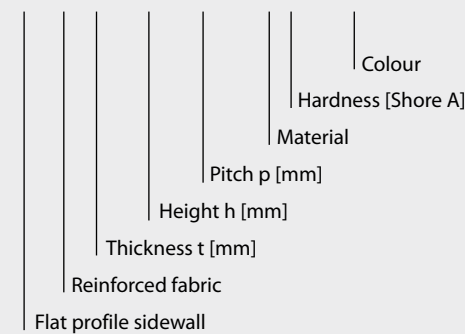

Key

- * Established in line with ISO 21181:2005
- ** When establishing the end diameter, take into account the d_{min} of the belt, of the lateral profile and of the sidewall. The highest value is important and must be adhered to. The d_{min} figures are guidelines. They were determined at normal ambient conditions (20 °C/50% humidity.) Lower temperatures require larger diameters.
- ¹⁾ May be lower for special applications. Please contact us.

Please note: the values stated are nominal and can fluctuate in a belt whose width is a result of production processes. Our products are constantly adapted to market requirements. Consequently, changes in technical parameters can occasionally occur. Therefore, please see the current product data sheets for specific information on designs and calculations.

Siegling – total belting solutions

Committed staff, quality oriented organization and production processes ensure the constantly high standards of our products and services.

Forbo Movement Systems complies with total quality management principles. Our quality management system has ISO 9001 certification at all production and fabrication sites. What's more, many sites have ISO 14001 environmental management certification.



Ref. no. 120-2
06/24-UDH - Reproduction of text or parts thereof only with our approval. Subject to change.



Our service – anytime, anywhere

Forbo Movement Systems employs around 2,500 people in its group of companies. Our products are manufactured in ten production facilities across the world.

You can find companies and agencies with warehouses and workshops in over 80 countries.

Service points are located in more than 300 places worldwide.

Forbo Siegling GmbH

Lilienthalstrasse 6/8, D-30179 Hannover

Phone +49 511 6704 0

www.forbo-siegling.com, siegling@forbo.com



MOVEMENT SYSTEMS