

# Belt scraper module and Scraper range

# siegling transilon conveyor and processing belts

## Belt scraper module

### Properties

- suitable for belt scrapers of urethane and polyester
- robust and compact design
- adjustable, continuously contact force
- adjustable scraper angle

### Technical data

Basic material fixing element	stainless steel
Contact force [N/mm]	0.1
Angle [°]	110 – 120
Belt widths [mm]	300 – 1500 (individual widths on request)
Basic material scraper	polyurethane (U) and polyester (E)

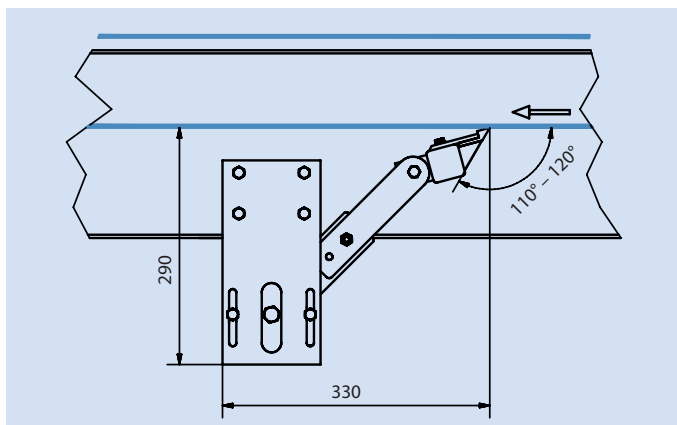

## Scraper range

Scraper U beige	Scraper U white	Scraper MD U blue	Scraper U blue	Scraper E cream white
Art. no. 882155	Art. no. 882156	Art. no. 882228	Art. no. 880137	Art. no. 880066
RAL 3012	RAL 9016	RAL 5003	RAL 5015	RAL 9001
Lip: Shore A 75 Body: Shore D 60	Lip: Shore A 85 Body: Shore D 78	Shore A 95	Lip: Shore A 85 Body: Shore D 78	Shore D 63
- Co-extruded - EU and FDA compliant	- Co-extruded - EU and FDA compliant	- Metal detectable - EU and FDA compliant	- Co-extruded - EU and FDA compliant	- Pyrolyse confirm - FDA compliant

All dimensions in mm.  
The dimensions given for the scrapers are subject to the usual tolerances of extruded plastic products.

Ref. no. 431-2  
09/18 - Reproduction of text or parts thereof only with our approval. Modifications reserved.