

## Data Sheet

### Heating Press for Melt Splices SM-HP-120/1250-P

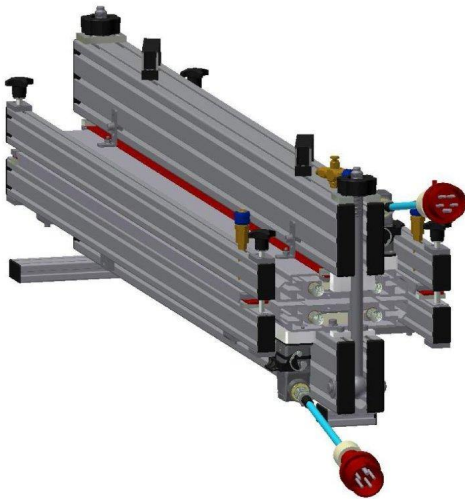

Heating presses are electrical heating devices, used for fabricating (splicing) Forbo Siegling belting material that is suitable for maximum temperatures for 200 °C and press inlet pressure of 5 bars.

The connecting heating devices of this series are outlined by their light, compact construction as well as the short heating up and cooling time. The connection cables of these devices are delivered in plug-in form.

The standard equipment of the heating presses includes: Hold-down bar, pressure equalizing metal sheets, shim bar set, textured fabric standard, separating paper, soft pad 1 mm, silicone fabric no. 1 and thermometer.

The application can be enhanced by using the following components: A portable cooling device, a control unit and a handy compressor.

Heating press for melt splices  
SM-HP-120/1250-P

**Should you need any further information, please contact directly the manufacturer:**

**Müssel Maschinenbau GmbH**  
Reichelsweierstrasse 8,  
D-95615 Marktredwitz  
[www.muessel.com](http://www.muessel.com)



Technical Data	SM-HP-120/1250-P	
Belt width max.	[mm]	1250
Belt length min.	[mm]	900
Splice max.	[mm]	Z-70
Heating plates length	[mm]	120
Length	[mm]	270
Width	[mm]	1510
Height	[mm]	425
Weight (net)	[kg]	83,0
Voltage	[V]	3x 400 / 3x 220
Capacity	[W]	2x 3250
Frequency	[Hz]	50
Heating up time	[min]	100
Cooling down time	[min]	2
Coolant		water
Air pressure max.	[bar]	5
Heating temperature max.	[°C]	200

#### Accessories

Material number	Designation
870356	WCD-55 cooling device
872863	ECU-AV-3 control unit
871524	ACU-8/200 compressor
872841	Sil. embossing mat SG
872847	Sil. embossing mat GSTR
872914	Sil. embossing mat LG
872989	Sil. embossing mat NP
872830	Textured fabric AR

Further Sil. embossing mat types on request!

Material number	Designation
872513	SM-HP-120/1250-P (3x 400V)
872514	SM-HP-120/1250-P (3x 220V)