

Data Sheet

Heating Press for Melt Splices SM-HP-180/3000-P

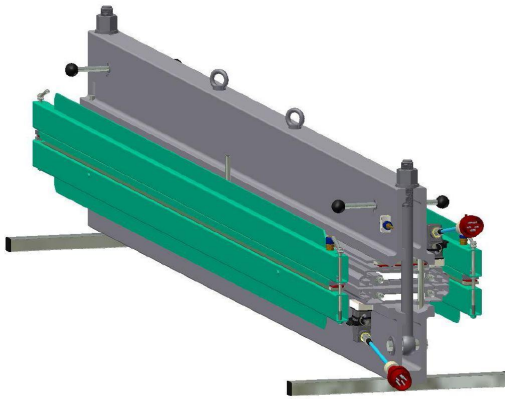

Electrical heating devices for fabricating melt splices using Forbo Siegling belt material.

The presses are entirely dismountable; therefore larger devices are also easily transportable. The connection cables of these heating presses are delivered in plug-in form.

The standard equipment of the heating presses of this type includes: Hold-down bar, pressure equalizing metal sheets, shim bars, textured fabric, separating paper, soft pad, silicone fabric and thermometer.

The application can be enhanced by using the following components: A portable cooling device, a control unit and a handy compressor.

Heating press for melt splices
SM-HP-180/3000-P

Should you need any further information, please contact directly the manufacturer:

Müssel Maschinenbau GmbH
Reichelsweiherstrasse 8,
D-95615 Marktredwitz
www.muessel.com

MÜSSEL
Maschinenbau GmbH



Accessories

| Material number | Designation |
|-----------------|---------------------------------------|
| 870356 | WCD-55 Cooling device |
| 872863 | ECU-AV-3 Control unit |
| 871524 | ACU-8/200 Compressor |
| 872609 | Adjustable hold-down bar (1 pc.) |
| 875044 | Pressure equalizing me. sh. spezial |
| 871077 | Sil. embossing mat FG |
| 871084 | Sil. embossing mat GSTR (fabric str.) |
| 871089 | Sil. embossing mat LG |
| 871096 | Sil. embossing mat NP |
| 871101 | Sil. embossing mat RF |
| 871107 | Sil. embossing mat SG |
| 871305 | Sil. embossing mat LN |
| 871905 | Sil. embossing mat RFF |
| 872089 | Sil. embossing mat VN |
| 872581 | Sil. embo. mat GSTR 60° (roller str.) |
| 872582 | Sil. embossing mat GSTR (roller str.) |
| 872950 | Sil. embossing mat AR |
| 870430 | Textured fabric AR |

Further silicone embossing mat types on request!

| Technical Data | | SM-HP-180/3000-P |
|--------------------------|-------|---------------------|
| Belt width max. | [mm] | 3000 |
| Belt length min. | [mm] | 1500 |
| Splice max. | [mm] | Z-110 and Z-Stepped |
| Heating plates length | [mm] | 180 |
| Length | [mm] | 460 |
| Width | [mm] | 3300 |
| Height | [mm] | 720 |
| Weight (net) | [kg] | 415,0 |
| Voltage | [V] | 3x 400 / 3x 220 |
| Capacity | [W] | 2x 4400 |
| Heating up time | [min] | approx. 30 |
| Cooling down time | [min] | approx. 5 |
| Coolant | | water |
| Air pressure | [bar] | 7 |
| Heating temperature max. | [°C] | 200 |

| Material number | Designation |
|-----------------|----------------------------|
| 870282 | SM-HP-180/3000-P (3x 400V) |
| 871342 | SM-HP-180/3000-P (3x 220V) |