

Data Sheet

Heating Press for Bonded Splices SB-HP-180/300

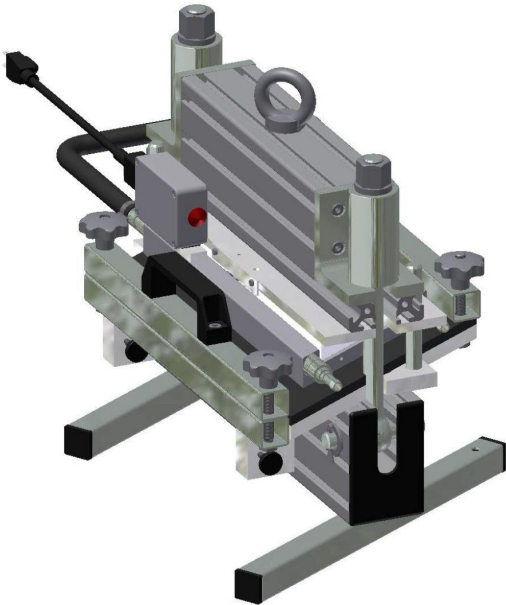

Heating presses are electrical heating devices used for fabricating (splicing) Forbo Siegling belting material that is suitable for temperatures of 110°C.

The hold-down bar can be removed by the aligned belt; the glued points are easily accessible and can be exactly pasted. After coating with glue the hold-down bar can be put on again and closed by fabric, soft pad, pressure equalizing metal sheets and the pre-heated top part.

The standard equipment of the heating press includes:
Pressure equalizing metal sheet, heat resistant foil, soft pad 2 mm, thermometer and cooling hose.

The connection cables of these heating presses are delivered in plug-in form.

Heating press for bonded splices
SB-HP-180/300

Should you need any further information, please
contact directly the manufacturer:

Müssel Maschinenbau GmbH
Reichelsweiherstrasse 8,
D-95615 Marktredwitz
www.muessel.com



Technical Data		SB-HP-180/300
Belt width max.	[mm]	300
Belt length min.	[mm]	1000
Heating plates length	[mm]	180
Length	[mm]	300
Width	[mm]	480
Height	[mm]	410
Weight (net)	[kg]	34,0
Voltage	[V]	110 / 230
Capacity	[W]	850
Splicing angle	[°]	60
Heating up time	[min]	15
Cooling down time	[min]	4
Coolant		Water
Heating temperature max.	[°C]	110

Accessories

Material number	Designation
871225	Timer
870356	Cooling device WCD-55

Material number	Designation
870076	SB-HP-180/300 (230V)
871298	SB-HP-180/300 (110V)