

Data Sheet

Punching press for Z-splices PP-ZP-V/80-6 and PP-ZP-V150/6

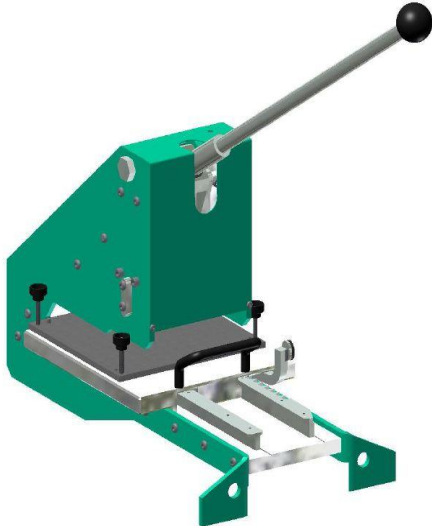

Punching presses of the PP-ZP-V/80-6 and PP-ZP-V/150-6 types are used for preparing Z-splices for belt widths up to 80 mm (PP-ZP-V/80-6) or 150 mm (PP-ZP-V/150-6) and belt thicknesses up to 6 mm. The splices are 35, 70 and 110 mm long.

Punching sets and hold-down bars are not included in the delivery of the punching presses and must be ordered separately!

Punching press for Z-splices
PP-ZP-V/80-6 and PP-ZP-V/150-6

Should you need any further information, please contact directly the manufacturer:

Müssel Maschinenbau GmbH
Reichelsweiherstrasse 8,
D-95615 Marktredwitz
www.muessel.com



Technical Data		PP-ZP-V/80-6	PP-ZP-V/150-6
Belt width max.	[mm]	80	150
Belt thickness max.	[mm]	6	6
Length	[mm]	440	500
Width	[mm]	210	210
Height	[mm]	360	360
Weight (net)	[kg]	16,0	18,5
Splicing angle	[°]	90	90
Type of splice		Z 35 x 5,75 Z 35 x 11,5 Z 70 x 11,5 Z 110 x 11,5	Z 35 x 5,75 Z 35 x 11,5 Z 70 x 11,5 Z 110 x 11,5

Accessories

Material number	Designation
872094	Punching set 35 x 5,75 mm
872093	Punching set 35 x 11,5 mm
872095	Punching set 70 x 11,5 mm
872096	Punching set 110 x 11,5 mm
872584	Hold-down bar for PP-ZP-V/80-6 for belts without profile
872585	Hold-down bar for PP-ZP-V/80-6 for belts with concentric profile
872090	Hold-down bar for PP-ZP-V/150-6 for belts without profile
872092	Hold-down bar for PP-ZP-V/150-6 for belts with concentric profile

Material number	Designation
872583	PP-ZP-V/80-6 basic tool
872089	PP-ZP-V/150-6 basic tool