

siegling transilon

conveyor and processing belts

The new sidewall range

NEW

forbo

MOVEMENT SYSTEMS

Sidewalls

		Article number	Thickness t [mm]	Height h [mm]	Width w [mm]	Pitch p [mm]	Shore A hardness	d _{min} approx. [mm]**	Operating temperature permitted [°C]	Special feature
PVC	FWG 5X40/P67-V60 green	882020	5	40	52	67	60	100	-10/+70	NEW robust due to fabric reinforcement
	FWG 5X60/P67-V60 green	882021	5	60	52	67	60	150	-10/+70	NEW robust due to fabric reinforcement
	FWG 5X80/P67-V60 green	882022	5	80	52	67	60	200	-10/+70	NEW robust due to fabric reinforcement
	FWG 5X40/P67-V60 white FDA	882023	5	40	52	67	60	100	-10/+70	NEW robust due to fabric reinforcement
	FWG 5X60/P67-V60 white FDA	882024	5	60	52	67	60	150	-10/+70	NEW robust due to fabric reinforcement
	FWG 5X80/P67-V60 white FDA	882025	5	80	52	67	60	200	-10/+70	NEW robust due to fabric reinforcement
	FW 5X33/P67-V60 green	881150	5	33	52	67	60	80	-10/+70	
	FW 5X40/P67-V60 white FDA	880640	5	40	52	67	60	100	-10/+70	
	FW 5X60/P67-V60 white FDA	880641	5	60	52	67	60	150	-10/+70	
	FW 5X80/P67-V60 white FDA	880642	5	80	52	67	60	200	-10/+70	
	FW 5X40/P67-V60 green	880646	5	40	52	67	60	100	-10/+70	
	FW 5X60/P67-V60 green	880647	5	60	52	67	60	150	-10/+70	
	FW 5X68/P67-V60 green	882127	5	68	52	67	60	175	-10/+70	
FW 5X80/P67-V60 green	880648	5	80	52	67	60	200	-10/+70		
Urethane	FW 2X40/P30-U87 blue-RAL5015 FDA	882221	2	40	36	30	87	80	-30/+80	NEW smaller pitch for smaller end diameters
	FW 2X40/P45-U87 blue-RAL5015 FDA	882220	2	40	36	45	87	100	-30/+80	
	FW 2X30/P30-U87 green FDA	882035	2	30	36	30	87	50	-30/+80	NEW smaller pitch for smaller end diameters
	FW 2X40/P30-U87 green FDA	882036	2	40	36	30	87	80	-30/+80	NEW smaller pitch for smaller end diameters
	FW 2X30/P45-U87 green FDA	881246	2	30	36	45	87	80	-30/+80	
	FW 2X40/P45-U87 green FDA	881247	2	40	36	45	87	100	-30/+80	
	FW 2X60/P45-U87 green FDA	881248	2	60	36	45	87	150	-30/+80	
	FW 2X30/P30-U87 white FDA	882037	2	30	36	30	87	50	-30/+80	NEW smaller pitch for smaller end diameters
	FW 2X40/P30-U87 white FDA	882038	2	40	36	30	87	80	-30/+80	NEW smaller pitch for smaller end diameters
	FW 2X30/P45-U87 white FDA	881243	2	30	36	45	87	80	-30/+80	
Polyester	FW 2X40/P45-E92 transparent FDA	881213	2	40	46	45	92	100	-10/+100	
	FW 2X60/P45-E92 transparent FDA	881214	2	60	46	45	92	150	-10/+100	
	FW 2X80/P67-E92 transparent FDA	881155	2	80	52	67	92	200	-10/+100	

The new sidewall range

Forbo Siegling's new sidewall range focuses even more strongly on food safety and offers new options for more compact conveyor designs.

The properties

smaller pitch
in PU sidewalls

light

resistant to oil
and grease

The advantages

▶ smaller drum diameters
(50 mm for 30 mm high sidewalls,
80 mm for 40 mm high sidewalls)

▶ ideal for small conveyors

▶ for use in the food and
pharmaceuticals industries

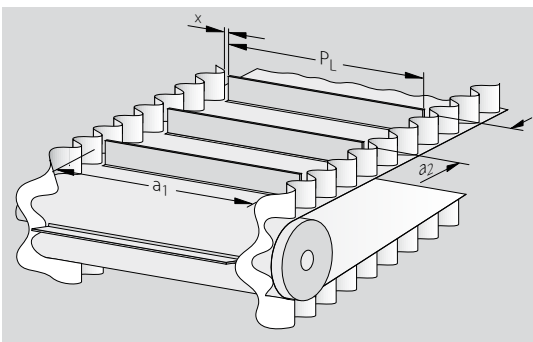

Finished belt sizes available:

Length: 2600 to 60000 mm
Width: 200 to 1300 mm

Recommended splicing method: Stepped overlap or stepped Z-splice

Inner distance between sidewalls: $a_1 = 100$ to 1200 mm
(for $a_1 < 150$ mm deviations in edge parallelism are possible)

Maximum profile length $P_{L\max}$: $P_{L\max} = a_1 - 2x$ (with $x = 2 \pm \frac{1}{2}$)

Sidewall amplitude tolerances: ± 1.0 mm

Manual splice tolerances: Amplitude ± 3.0 mm; spacing distance ± 1.5 mm

Recommended conveyor belt types

	Article number	Total thickness approx. [mm]	Weight approx. [kg/m ²]	Pull at 1% elongation (K _{1%} relaxed) [N/mm width]*	d _{min} approx. [mm]**	Operating temperature permitted [°C]	Special feature
PVC	E 10/M V1/V10 green	900066	2.85	3.3	6	60	exceptionally robust
	E 10/M V1/V10 MT white FDA	900092	2.85	3.3	6	60	exceptionally robust
	E 12/2 U0/V7 green	900045	2.85	3.4	10	60	
	E 12/2 U0/V20 MT-NA white FDA	900050	3.7	4.4	10	60	non-antistatic
Urethane	E 6/2 U0/U2-M green FDA	906191	1.9	2	5.5	50	exceptionally laterally stiff
	E 8/2 U0/U2 green FDA	900320	1.4	1.6	6.5	40/25 (Z)	
	E 8/2 U0/U8 transparent FDA	900024	2	2.2	7.5	60	
	NP 6698 (E 14/2 U0/U4-M MT white FDA)	906698	2.9	3	16	50	NEW exceptionally laterally stiff, ideal for welding profiles and sidewalls
	E 18/H U0/U2 MT white FDA	906420	1.75	1.75	21	20 ¹⁾	only limited suitability for swan neck conveyors
Polyester	E 12/2 E0/E3 MT-TT transparent	900348	1.7	1.8	10.5	50 ¹⁾	
	E 18/3 E0/E3 MT-TT transparent	900350	2.6	2.8	14	60	

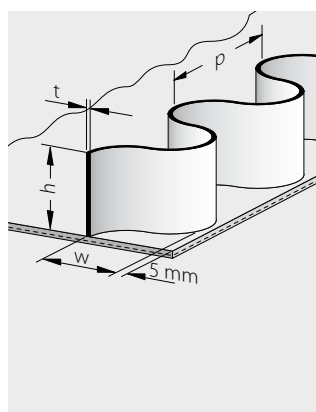

Type key

FWG 5 x 40 / P67 - V60 green

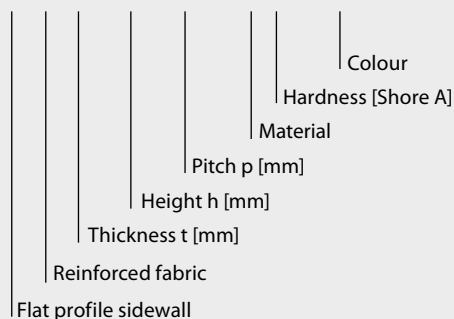

Key

- * Established in line with ISO 21181:2005
- ** When establishing the end diameter, take into account the d_{min} of the belt, of the lateral profile and of the sidewall. The highest value is important and must be adhered to. The d_{min} figures are guidelines. They were determined at normal ambient conditions (20°C/50% humidity.) Lower temperatures require larger diameters.
- ¹⁾ May be lower for special applications. Please contact us.

Please note: the values stated are nominal and can fluctuate in a belt whose width is a result of production processes. Our products are constantly adapted to market requirements. Consequently, changes in technical parameters can occasionally occur. Therefore, please see the current product data sheets for specific information on designs and calculations.



MOVEMENT SYSTEMS

Siegling – total belting solutions

Committed staff, quality-orientated organisation and production processes ensure the constantly high standards of our products and services. The Forbo Siegling Quality Management System is certified in accordance with ISO 9001.

In addition to product quality, environmental protection is an important corporate goal. Early on we also introduced an environmental management system, certified in accordance with ISO 14001.



Forbo Siegling service – anytime, anywhere

The Forbo Siegling Group employs more than 2,000 people. Our products are manufactured in nine production facilities across the world. You can find companies and agencies with warehouses and workshops in over 80 countries. Forbo Siegling service points are located in more than 300 places worldwide.