



siegling fullsan
homogenous belts

ENGINEERING MANUAL

Fullsan compliments the Forbo Movement Systems conveyor belt range with homogenous belts made from high-grade polyurethane. Our extensive experience in light materials handling is your guarantee not only of outstanding product quality, but also of competent advice, rapid availability and practice-oriented service.



BETTER HYGIENE WITH FULLSAN

Fullsan is virtually resistant to contamination of oil, grease, moisture and bacteria. Fullsan is very easy to clean, and is exceptionally well suited to use in especially hygiene-critical applications (dairy products, dough processing, meat and poultry processing, as well as other food processing applications).

Fullsan is manufactured in three series. With optional profiles (flights, sidewalls), they can be adapted to countless conveying tasks.

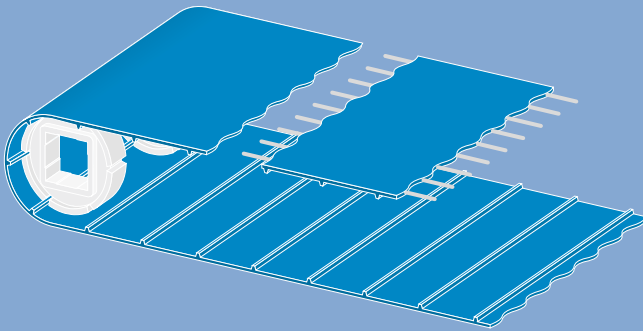

Fullsan Positive Drive

Polyurethane belt with homogenous belt body or optionally with fully enclosed tension members. Form-fit (positively driven) power transmission via sprockets. Full width drive bars on the underside of the belt.

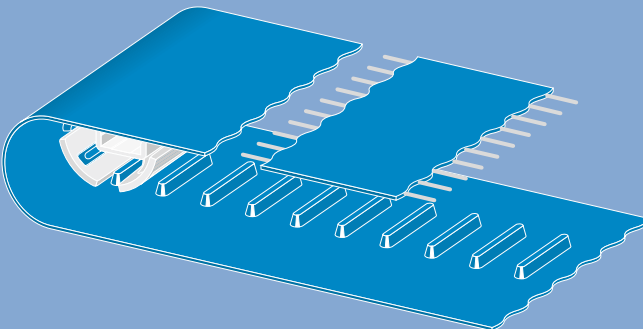

Fullsan Center Drive

Polyurethane belt with homogenous belt body or optionally with fully enclosed tension members. Form-fit (positively driven) power transmission via sprocket drums. With one centric or depending on width up to three parallel lug rows.

In addition to their hygiene benefits, Fullsan belts with Center Drive (CD) or Positive Drive (PD) offer other application engineering advantages: the form-fit sprocket drive means the belts are slip-free and enables accurate positioning.

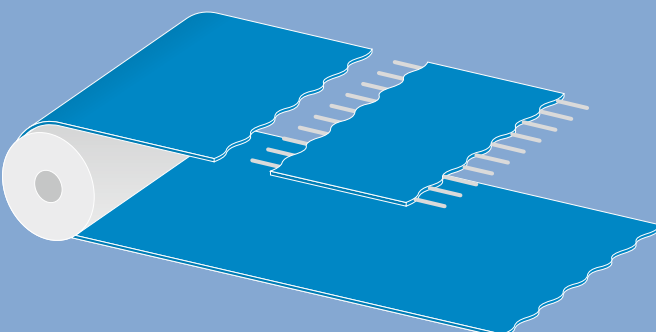

Fullsan Flat

Polyurethane belt with homogeneous belt body or optionally with fully enclosed tension members. For tension driven applications.

INDEX

1 Basics.....	6	2 Conveyor design	28
1.1 Technical data	8	2.1 General	30
Fullsan Positive Drive.....	8	Conveyor components	30
Fullsan Center Drive.....	10	Hygienic design	32
Fullsan Flat	12	Materials	33
Type key	14	2.2 Notes on conveyor construction	34
Retainer Rings	15	Frame and support	34
1.2 Belt fabrication	16	Belt side guides	35
Splice types	16	Conveyor speed	36
Belt features	17	Conveyor length	36
Profiles (PU-flights)	18	Expansion/contraction due to temperature ...	36
Profiles (PU top side guides).....	18	Take-ups	37
PU side walls	20	Quick release tensioning devices	37
1.3 Belt selection and sizing	22	Scrapers	38
Which Fullsan type for which application?	22	Side limits	39
Drive types	23	Feeding in the transported material	40
Pre-tension	24	Designing axes and shafts	40
Calculating the required belt length	24	Sprockets	42
1.4 Factors influencing belt life	25	2.3 Belt support on the carrying side	44
1.5 Cleaning	26	General	44
		Flat (table) supports	45
		Parallel wearstrips	46
		V-shaped arrangement of wearstrips	48
		Supporting the belt with rollers	50
		2.4 Belt support on the return side	51
		General	51
		Supporting the belt with rollers	52
		Sliding belt supports	52
		Belt sag	53
		2.5 Fullsan Positive Drive	54
		General	54
		Drive types	54
		Drive and idler shafts	56
		Belt tracking	58
		2.6 Fullsan Center Drive	60
		General	60
		Drive types	60
		Drive and idler shafts	62
		Belt tracking	64

2.7	Fullsan Flat	66
	General	66
	Drive types	66
	Drive and idler shafts	68
	Belt tracking	70
3	Conveyor layouts	76
3.1	Horizontal conveyors	78
	General	78
	Conveyor layouts	78
3.2	Incline/decline conveyors	79
	General	79
	Incline conveyor	79
	Decline conveyor	79
3.3	Hockey-stick and swan-neck conveyors	80
	General	80
	Use of profiles (flights, sidewalls) and bending/counter-bending radii	81
	Drive	81
	Belt guidance in the concave curve (top side of belt)	82
	Belt guidance in the convex curve (underside of belt)	83
3.4	Troughed conveyors	84
	General	84
	Transitional area between end pulley and trough	84
	Trough angle	84
	Fullsan series and trough shape	85

4 Calculations.....88

4.1	Calculations	90
	Input variables	90
	Calculation of the adjusted belt length	91
	Calculation of the effective belt pull	92
	Calculation of the adjusted belt pull	94
	Calculation of the admissible belt pull	95
	Validation of the belt selection	96
	Shaft calculation– Shaft load	97
	Shaft calculation – Torque	98
	Shaft calculation – Deflection	99
	Shaft calculation – Torsion	100
	Shaft calculation – Power requirement	101
	Shaft calculation – Shaft revolutions	101
	Legal Notes	102



1 BASICS

- 1.1 Technical data
- 1.2 Belt fabrication
- 1.3 Belt selection and sizing
- 1.4 Factors influencing belt life
- 1.5 Cleaning

1.1 TECHNICAL DATA

Fullsan Positive Drive

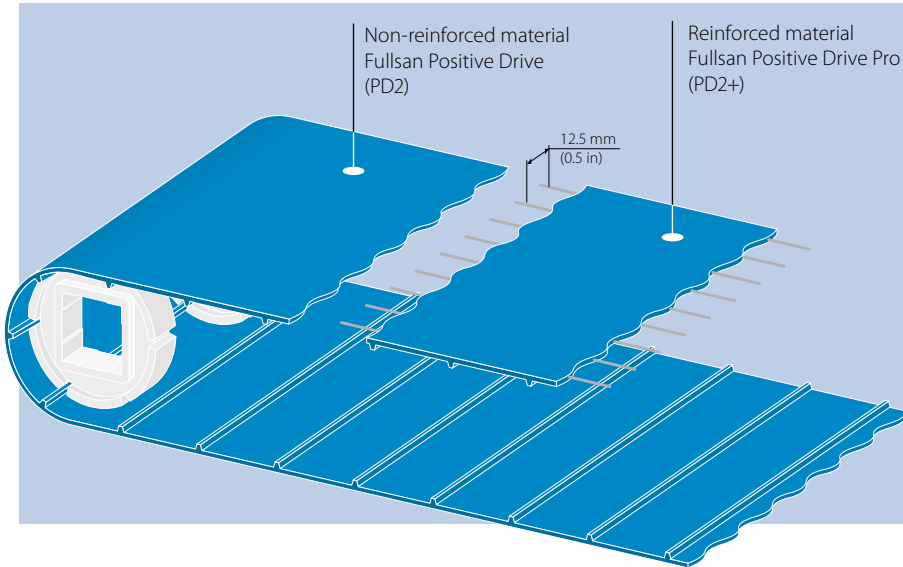

Top face · Optional surfaces

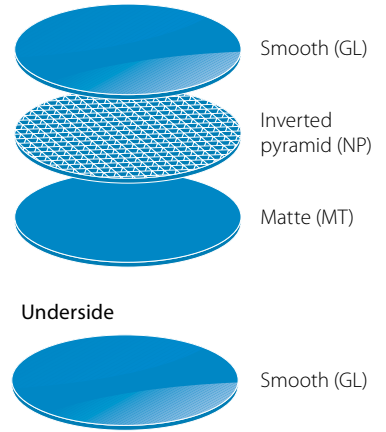

Fullsan Positive Drive is used as a homogenous belt (PD2), or one with fully enclosed cords (PD2+). The flat polyurethane belt width has teeth over the whole belt width and a form-fit drive. As a result, the belts don't slip and can be positioned very accurately.

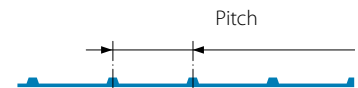

Technical information Fullsan Positive Drive

Belt type	Article number	Belt thickness approx. [mm (in)] ± 0.15 (0.006)	Tooth height approx. [mm (in)]	Pitch [mm (in)]	Nominal belt pull [N/mm width (lbf/ft width)]*	Drum diameter** without counter-bending min. [mm (in)]	Drum diameter** with counter-bending min. [mm (in)]	Operating temperature allowed [°C (°F)]	Belt weight [kg/m² (lb/ft²)]
PD2 U30 GL-NA-HACCP BL FDA	640006	3.0 (0.12)	5.0 (0.2)	49.8 (1.96)	6 (411)	95 (3.74)	60 (2.36)	-10/+70 (14/158)	4.5 (0.92)
PD2 U30 MT-NA-HACCP BL FDA	640007	3.0 (0.12)	5.0 (0.2)	49.8 (1.96)	6 (411)	95 (3.74)	60 (2.36)	-10/+70 (14/158)	4.5 (0.92)
PD2+ U30 GL-NA-HACCP BL FDA	640009	3.0 (0.12)	5.0 (0.2)	49.9 (1.96)	9 (617)	95 (3.74)	40 (1.57)	-10/+70 (14/158)	4.1 (0.84)
PD2+ U30 MT-NA-HACCP BL FDA	640010	3.0 (0.12)	5.0 (0.2)	49.9 (1.96)	9 (617)	95 (3.74)	40 (1.57)	-10/+70 (14/158)	4.1 (0.84)
PD2+ U30 NP-NA-HACCP BL FDA	640011	3.4 (0.13)	5.0 (0.2)	49.9 (1.96)	9 (617)	95 (3.74)	40 (1.57)	-10/+70 (14/158)	4.1 (0.84)

* The nominal belt pull were established in standard ambient conditions (20°C/50% humidity).

** When establishing the drum diameter, the d_{min} of the belt, flight, and side wall must be allowed for. The highest value is the relevant one and must be no lower. The d_{min} specifications are guidelines. They were established in standard ambient conditions (20°C/50% humidity). Lower temperatures require larger diameters.

Fabrication/widths supplied

Fullsan Positive Drive belts are supplied fabricated (if required with profiles and side walls), or as roll material. The deliverable width starts at 50 mm and ends depending on the belt type at up to 1800 mm (2.0 – 70.9 in). Regarding the available width please contact customer service.

Caution: Lengthways cuts in the reinforced versions are made in the center between the cords. Therefore, the potential width of these belts is always a multiple of 12.5 mm (0.5 in).

The potential length of the belt is a multiple of the tooth pitch. The spacing between flights and pitch of side walls might also have to be considered.

Sprockets for Fullsan Positive Drive 2 and Positive Drive 2 Pro

Sprocket type	Article number	Pitch circle diameter D_0 [mm (in)]	No. of teeth	Material	Color	Axle diameter [mm (in)]	Sprocket width W_{spr} [mm (in)]	Sprocket weight [kg (lb)]
Positive Drive 2 Pro - Molded sprockets								
PD2-Z8 SPR POM BL SQ40MM	648014	126.9 (4.99)	8	POM	blue	40.0 (1.57) SQ	35 (1.38)	0.176 (0.388)
PD2-Z8 SPR POM BL SQ1.5IN	648013	126.9 (4.99)	8	POM	blue	38.1 (1.50) SQ	35 (1.38)	0.184 (0.406)
PD2-Z10 SPR POM BL SQ40MM*	648016	159.4 (6.28)	10	POM	blue	40.0 (1.57) SQ	35 (1.38)	0.240 (0.529)
PD2-Z10 SPR POM BL SQ1.5IN*	648015	159.4 (6.28)	10	POM	blue	38.1 (1.50) SQ	35 (1.38)	0.248 (0.546)
PD2-Z12 SPR POM BL SQ40MM	648018	191.9 (7.56)	12	POM	blue	40.0 (1.57) SQ	35 (1.38)	0.258 (0.569)
PD2-Z12 SPR POM BL SQ1.5IN	648017	191.9 (7.56)	12	POM	blue	38.1 (1.50) SQ	35 (1.38)	0.266 (0.587)
Positive Drive 2 and Positive Drive 2 Pro - Machined sprockets								
		126.9 (4.99)	8	UHMW-PE	white	40.0 (1.57) SQ	35 (1.38)	0.319 (0.703)
		126.9 (4.99)	8	UHMW-PE	white	38.1 (1.50) SQ	35 (1.38)	0.325 (0.717)
		159.4 (6.28)	10	UHMW-PE	white	40.0 (1.57) SQ	35 (1.38)	0.539 (1.188)
		159.4 (6.28)	10	UHMW-PE	white	38.1 (1.50) SQ	35 (1.38)	0.545 (1.202)
		191.9 (7.56)	12	UHMW-PE	white	40.0 (1.57) SQ	35 (1.38)	0.817 (1.801)
		191.9 (7.56)	12	UHMW-PE	white	38.1 (1.50) SQ	35 (1.38)	0.822 (1.813)

* Coming soon

Further axle diameters and sprocket sizes (also over the whole belt width) on request. Drum drives are also available. Contact our customer service for more information and recommendations.

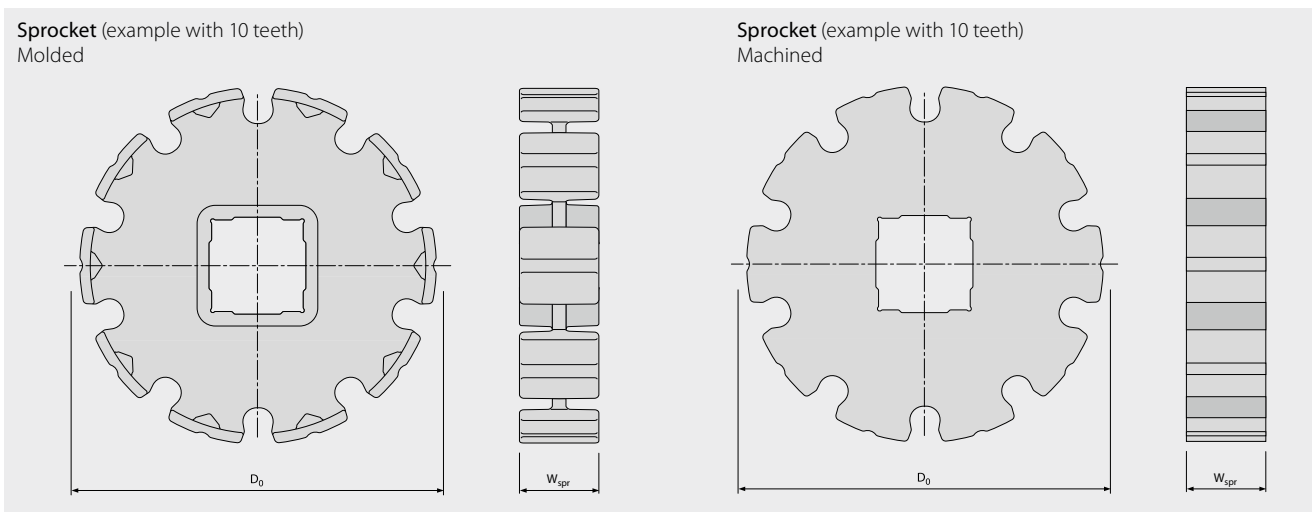

1.1 TECHNICAL DATA

Fullsan Center Drive

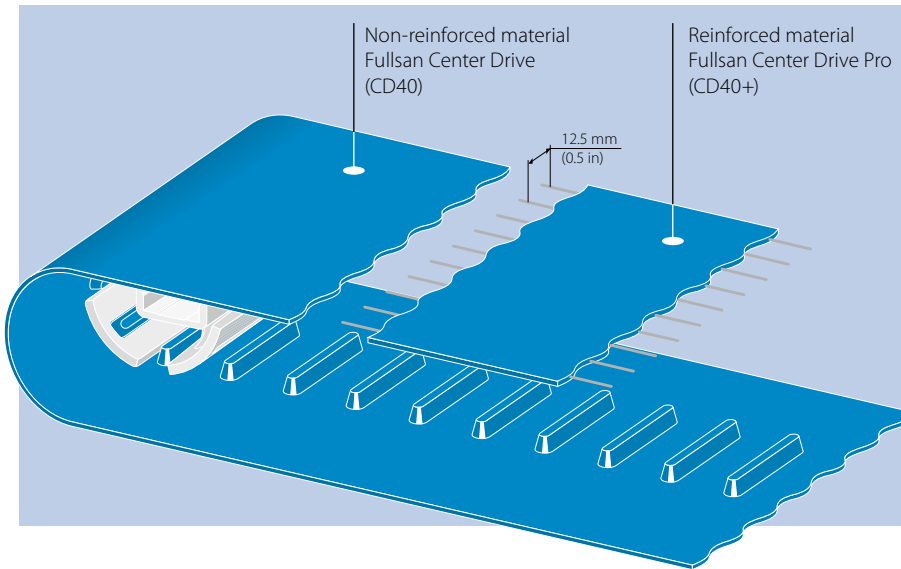

Top face · Optional surfaces

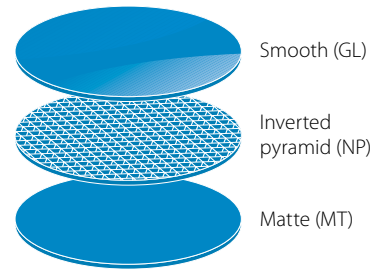

Underside

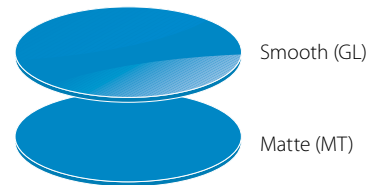

Fullsan Center Drive is used as a homogenous belt (CD40), or one with fully enclosed cords (CD40+). Depending on the belt width, the flat polyurethane belt width is driven by one, two or three rows of teeth in a form-fit manner. As a result, the belts don't slip, track automatically and position accurately.

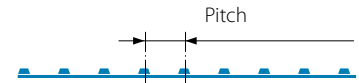

Technical information Fullsan Center Drive

Belt type	Article number	Belt thickness approx. [mm (in)] ± 0.15 (0.006)	Tooth height approx. [mm (in)]	Pitch [mm (in)]	Nominal belt pull [N/mm width (lb/ft width)]*	Drum diameter** without counter-bending min. [mm (in)]	Drum diameter** with counter-bending min. [mm (in)]	Operating temperature allowed [°C (°F)]	Belt weight [kg/m² (lb/ft²)]	Weight of teeth [g/mm (lb/in)]
CD40 1R U30 GL-NA-HACCP BL FDA	640026	3.0 (0.12)	7.5 (0.3)	40 (1.57)	2.0 (137) ¹⁾	80 (3.14)	125 (4.29)	-10/+70 (14/158)	3.65 (0.75)	0.18 (0.01)
CD40 1R U30 MT-NA-HACCP BL FDA	640027	3.0 (0.12)	7.5 (0.3)	40 (1.57)	2.0 (137) ¹⁾	80 (3.14)	125 (4.29)	-10/+70 (14/158)	3.65 (0.75)	0.18 (0.01)
CD40 1R U30 NP-NA-HACCP BL FDA	640028	3.4 (0.13)	7.5 (0.3)	40 (1.57)	2.0 (137) ¹⁾	80 (3.14)	125 (4.29)	-10/+70 (14/158)	3.65 (0.75)	0.18 (0.01)
CD40+ 1R U30 GL-NA-HACCP BL FDA	640029	3.0 (0.12)	7.5 (0.3)	40 (1.57)	5.0 (342) ¹⁾	80 (3.14)	125 (4.29)	-10/+70 (14/158)	3.5 (0.72)	0.18 (0.01)
CD40+ 1R U30 MT-NA-HACCP BL FDA	640030	3.0 (0.12)	7.5 (0.3)	40 (1.57)	5.0 (342) ¹⁾	80 (3.14)	125 (4.29)	-10/+70 (14/158)	3.5 (0.72)	0.18 (0.01)
CD40+ 1R U30 NP-NA-HACCP BL FDA	640031	3.4 (0.13)	7.5 (0.3)	40 (1.57)	5.0 (342) ¹⁾	80 (3.14)	125 (4.29)	-10/+70 (14/158)	3.5 (0.72)	0.18 (0.01)
CD40 2R U30 GL-NA-HACCP BL FDA	640032	3.0 (0.12)	7.5 (0.3)	40 (1.57)	2.0 (137) ¹⁾	80 (3.14)	125 (4.29)	-10/+70 (14/158)	3.65 (0.75)	0.36 (0.02)
CD40 2R U30 MT-NA-HACCP BL FDA	640033	3.0 (0.12)	7.5 (0.3)	40 (1.57)	2.0 (137) ¹⁾	80 (3.14)	125 (4.29)	-10/+70 (14/158)	3.65 (0.75)	0.36 (0.02)
CD40 2R U30 NP-NA-HACCP BL FDA	640034	3.4 (0.13)	7.5 (0.3)	40 (1.57)	2.0 (137) ¹⁾	80 (3.14)	125 (4.29)	-10/+70 (14/158)	3.65 (0.75)	0.36 (0.02)
CD40+ 2R U30 GL-NA-HACCP BL FDA	640035	3.0 (0.12)	7.5 (0.3)	40 (1.57)	5.0 (342) ¹⁾	80 (3.14)	125 (4.29)	-10/+70 (14/158)	3.5 (0.72)	0.36 (0.02)
CD40+ 2R U30 MT-NA-HACCP BL FDA	640036	3.0 (0.12)	7.5 (0.3)	40 (1.57)	5.0 (342) ¹⁾	80 (3.14)	125 (4.29)	-10/+70 (14/158)	3.5 (0.72)	0.36 (0.02)
CD40+ 2R U30 NP-NA-HACCP BL FDA	640037	3.4 (0.13)	7.5 (0.3)	40 (1.57)	5.0 (342) ¹⁾	80 (3.14)	125 (4.29)	-10/+70 (14/158)	3.5 (0.72)	0.36 (0.02)
CD40 3R U30 GL-NA-HACCP BL FDA	640038	3.0 (0.12)	7.5 (0.3)	40 (1.57)	2.0 (137) ¹⁾	80 (3.14)	125 (4.29)	-10/+70 (14/158)	3.65 (0.75)	0.54 (0.03)
CD40 3R U30 MT-NA-HACCP BL FDA	640039	3.0 (0.12)	7.5 (0.3)	40 (1.57)	2.0 (137) ¹⁾	80 (3.14)	125 (4.29)	-10/+70 (14/158)	3.65 (0.75)	0.54 (0.03)
CD40 3R U30 NP-NA-HACCP BL FDA	640040	3.4 (0.13)	7.5 (0.3)	40 (1.57)	2.0 (137) ¹⁾	80 (3.14)	125 (4.29)	-10/+70 (14/158)	3.65 (0.75)	0.54 (0.03)
CD40+ 3R U30 GL-NA-HACCP BL FDA	640041	3.0 (0.12)	7.5 (0.3)	40 (1.57)	5.0 (342) ¹⁾	80 (3.14)	125 (4.29)	-10/+70 (14/158)	3.5 (0.72)	0.54 (0.03)
CD40+ 3R U30 MT-NA-HACCP BL FDA	640042	3.0 (0.12)	7.5 (0.3)	40 (1.57)	5.0 (342) ¹⁾	80 (3.14)	125 (4.29)	-10/+70 (14/158)	3.5 (0.72)	0.54 (0.03)
CD40+ 3R U30 NP-NA-HACCP BL FDA	640043	3.4 (0.13)	7.5 (0.3)	40 (1.57)	5.0 (342) ¹⁾	80 (3.14)	125 (4.29)	-10/+70 (14/158)	3.5 (0.72)	0.54 (0.03)

* The nominal belt pull were established in standard ambient conditions (20 °C/50% humidity).

** When establishing the drum diameter, the d_{min} of the belt, flight, and side wall must be allowed for. The highest value is the relevant one and must be no lower. The d_{min} specifications are guidelines.

They were established in standard ambient conditions (20 °C/50% humidity). Lower temperatures require larger diameters.

¹⁾ For belts up to 600 mm (23.6 in) wide. Values for belt widths > 600 mm (23.6 in) on request.

Fabrication/widths supplied

Fullsan Center Drive belts are supplied fabricated (if required with profiles and side walls), or as roll material. The deliverable width starts at 100 mm and ends depending on the belt type at up to 1800 mm (3.9 – 70.9 in). Regarding the available width please contact customer service.

Caution: Lengthways cuts in the reinforced versions are made in the center between the cords. Therefore, the potential width of these belts is always a multiple of 25 mm (1.0 in).

The potential length of the belt is a multiple of the tooth pitch. The spacing between flights and pitch of side walls might also have to be considered.

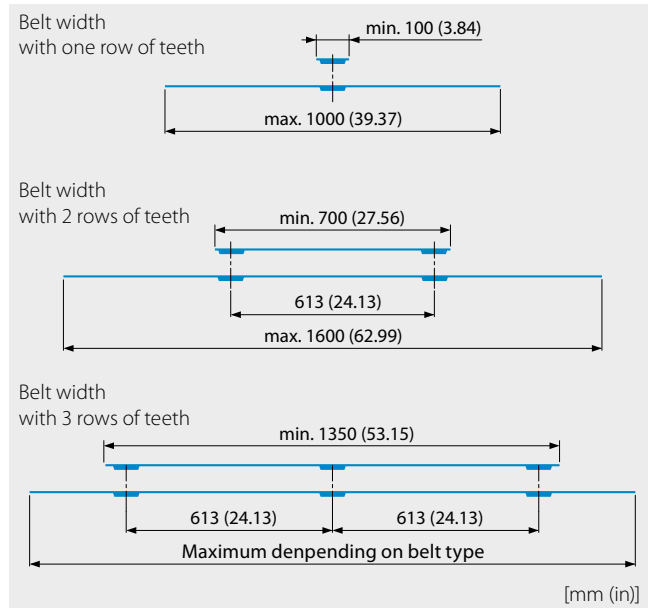

Sprockets for Fullsan Center Drive and Center Drive Pro

Sprocket type	Article number	Pitch circle diameter D_0 [mm (in)]	No. of teeth	Material	Color	Axle diameter [mm (in)]	Sprocket weight [kg (lb)]
Center Drive · Molded sprockets							
CD40-Z8 SPR POM BL SQ40MM	648007	100.6 (3.96)	8	POM	blue	40.0 (1.57) SQ	0.257 (0.566)
CD40-Z8 SPR POM BL SQ1.5IN	648008	100.6 (3.96)	8	POM	blue	38.4 (1.5) SQ	0.268 (0.591)
CD40-Z10 SPR POM BL SQ40MM	648009	126.5 (4.98)	10	POM	blue	40.0 (1.57) SQ	0.318 (0.700)
CD40-Z10 SPR POM BL SQ1.5IN	648010	126.5 (4.98)	10	POM	blue	38.4 (1.5) SQ	0.329 (0.726)
CD40-Z12 SPR POM BL SQ40MM	648011	152.4 (6)	12	POM	blue	40.0 (1.57) SQ	0.392 (0.865)
CD40-Z12 SPR POM BL SQ1.5IN	648012	152.4 (6)	12	POM	blue	38.4 (1.5) SQ	0.404 (0.890)
Center Drive · Machined sprockets							
		100.6 (3.96)	8	UHMW-PE	white	40.0 (1.57) SQ	0.488 (1.076)
		100.6 (3.96)	8	UHMW-PE	white	38.4 (1.5) SQ	0.503 (1.109)
		126.5 (4.98)	10	UHMW-PE	white	40.0 (1.57) SQ	0.878 (1.936)
		126.5 (4.98)	10	UHMW-PE	white	38.4 (1.5) SQ	0.894 (1.971)
		152.4 (6)	12	UHMW-PE	white	40.0 (1.57) SQ	1.376 (3.034)
		152.4 (6)	12	UHMW-PE	white	38.4 (1.5) SQ	1.391 (3.067)

Further axle diameters and sprocket sizes (also over the whole belt width) on request. Drum drives are also available. Contact our customer service for more information and recommendations.

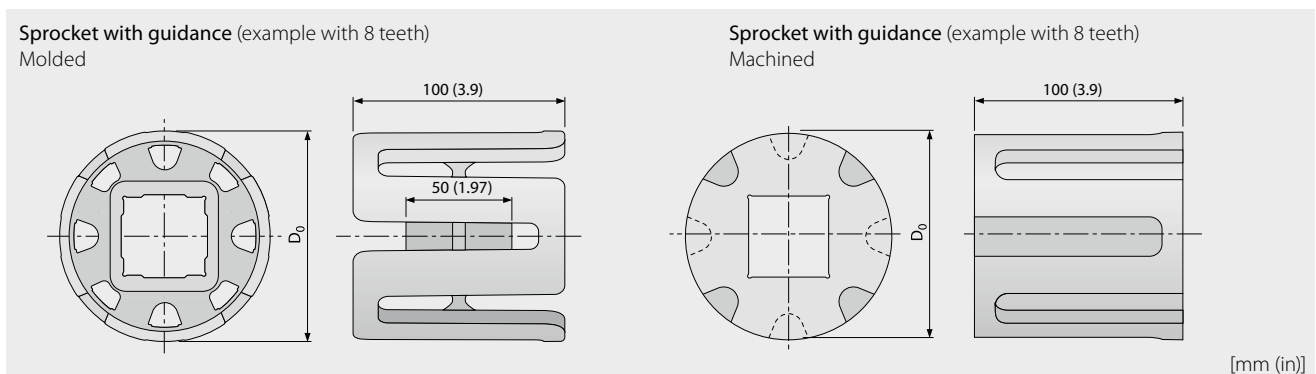

1.1 TECHNICAL DATA

Fullsan Flat

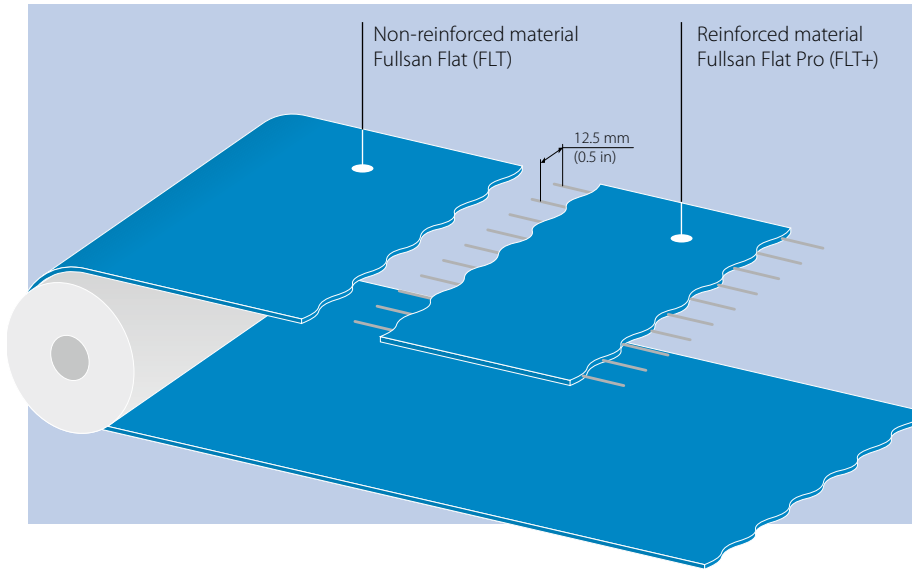

Top face · Optional surfaces

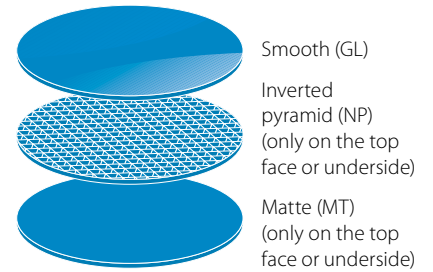

Fullsan Flat (FLT) is used as a homogenous belt, or with fully enclosed cords (FLT+). The flat polyurethane belt is friction driven via an end drum.

Technical information Fullsan Flat

Belt type	Article number	Belt thickness approx. [mm (in)] ± 0.15 (0.006)	Tensile force at 1% elongation ($k_{1\%}$ relaxed) [N/mm width (lb/ft width)]*	Drum diameter** without counter-bending min. [mm (in)]	Drum diameter** with counter-bending min. [mm (in)]	Operating temperature allowed [°C (°F)]	Belt weight [kg/m ² (lb/ft ²)]
FLT U30 GL/GL-NA-HACCP BL FDA	640012	3 (0.12)	1.75 (120)	40 (1.57)	40 (1.57)	-10/+70 (14/158)	3.65 (0.75)
FLT U30 GL/MT-NA-HACCP BL FDA	640013	3 (0.12)	1.75 (120)	40 (1.57)	40 (1.57)	-10/+70 (14/158)	3.65 (0.75)
FLT U30 GL/NP-NA-HACCP BL FDA	640014	3.4 (0.13)	1.75 (120)	40 (1.57)	40 (1.57)	-10/+70 (14/158)	3.65 (0.75)
FLT U30 MT/GL-NA-HACCP BL FDA	640015	3 (0.12)	1.75 (120)	40 (1.57)	40 (1.57)	-10/+70 (14/158)	3.65 (0.75)
FLT U30 MT/NP-NA-HACCP BL FDA	640016	3.4 (0.13)	1.75 (120)	40 (1.57)	40 (1.57)	-10/+70 (14/158)	3.65 (0.75)
FLT U30 NP/GL-NA-HACCP BL FDA	640017	3.4 (0.13)	1.75 (120)	40 (1.57)	40 (1.57)	-10/+70 (14/158)	3.65 (0.75)
FLT U30 NP/MT-NA-HACCP BL FDA	640018	3.4 (0.13)	1.75 (120)	40 (1.57)	40 (1.57)	-10/+70 (14/158)	3.65 (0.75)
FLT+ U30 GL/GL-NA HACCP BL FDA	640019	3 (0.12)	9 (617)	40 (1.57)	40 (1.57)	-10/+70 (14/158)	3.5 (0.72)
FLT+ U30 GL/MT-NA-HACCP BL FDA	640020	3 (0.12)	9 (617)	40 (1.57)	40 (1.57)	-10/+70 (14/158)	3.5 (0.72)
FLT+ U30 GL/NP-NA HACCP BL FDA	640021	3.4 (0.13)	9 (617)	40 (1.57)	40 (1.57)	-10/+70 (14/158)	3.5 (0.72)
FLT+ U30 MT/GL-NA-HACCP BL FDA	640022	3 (0.12)	9 (617)	40 (1.57)	40 (1.57)	-10/+70 (14/158)	3.5 (0.72)
FLT+ U30 MT/NP-NA-HACCP BL FDA	640023	3.4 (0.13)	9 (617)	40 (1.57)	40 (1.57)	-10/+70 (14/158)	3.5 (0.72)
FLT+ U30 NP/GL-NA HACCP BL FDA	640024	3.4 (0.13)	9 (617)	40 (1.57)	40 (1.57)	-10/+70 (14/158)	3.5 (0.72)
FLT+ U30 NP/MT-NA-HACCP BL FDA	640025	3.4 (0.13)	9 (617)	40 (1.57)	40 (1.57)	-10/+70 (14/158)	3.5 (0.72)

* Established in standard ambient conditions (20°C/50% humidity).

** When establishing the drum diameter, the d_{min} of the belt, flight, and side wall must be allowed for. The highest value is the relevant one and must be no lower. The d_{min} specifications are guidelines.

They were established in standard ambient conditions (20°C/50% humidity). Lower temperatures require larger diameters.

Fabrication/widths supplied

Fullsan Flat belts are supplied fabricated (if required with profiles and side walls), or as roll material. The deliverable width starts at 25 mm and ends depending on the belt type at up to 2000 mm (1.0–78.7 in). Regarding the available width please contact customer service.

Caution: Lengthways cuts in the reinforced versions are made in the center between the cords. Therefore, the potential width of these belts is always a multiple of 12.5 mm (0.5 in).

When establishing the belt length, the spacing between flights and pitch of side walls might also have to be taken into account.

1.1 TECHNICAL DATA

Type key for all Fullsan series

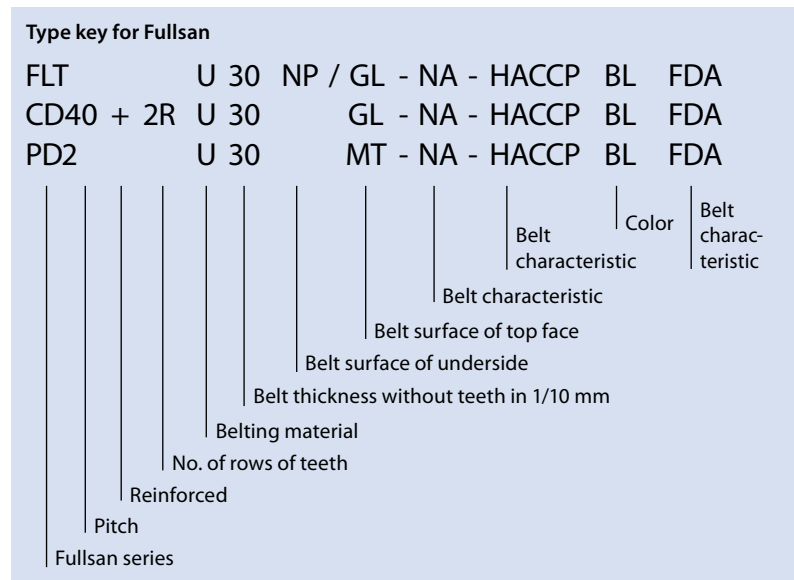

- FLT** = Flat top
- CD** = Center Drive
- PD** = Positive Drive
- +** = reinforced version (Pro)
- 1R/2R/3R** = no. of rows of teeth
- U** = polyurethane
- GL** = smooth
- MT** = matte
- NP** = inverted pyramid
- NA** = not antistatic
- HACCP** = HACCP concept support
- FDA** = food safe compliance with EC/FDA
- BL** = blue

 blue (RAL 5015)

Retainer Rings

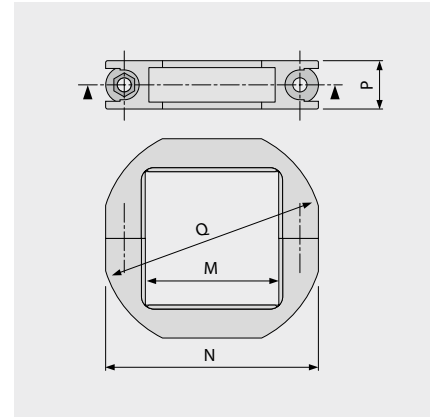
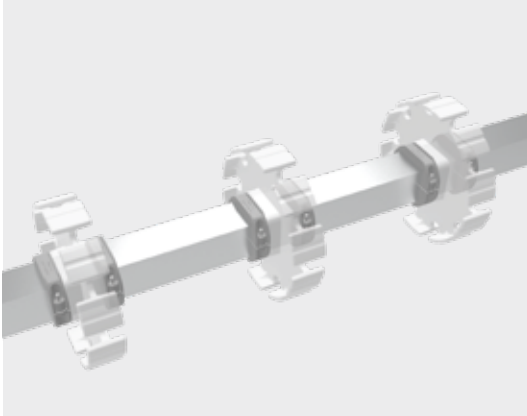

Shaft size	Article number	Designation*	Main dimensions [mm (in)]			
			M	N	P	Q
SQ 40 mm	98168799	RTR PA LG (SS) SQ40MM	41 (1.6)	65 (2.6)	15 (0.6)	68 (2.7)
SQ 60 mm	98168899	RTR PA LG (SS) SQ60MM	61 (2.4)	86 (3.4)	15 (0.6)	97 (3.8)
SQ 1½ in	98168999	RTR PA LG (SS) SQ1.5IN	39 (1.5)	65 (2.6)	15 (0.6)	67 (2.6)
SQ 2½ in	98169099	RTR PA LG (SS) SQ2.5IN	64 (2.5)	89 (3.5)	15 (0.6)	100 (3.9)

* SS = stainless steel screw and nut





1.2 BELT FABRICATION

Splice types

When choosing the type of endless splicing, take into account:

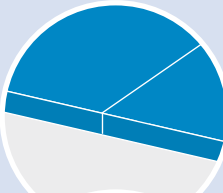
- Hygienic aspects
- Material being conveyed
- Tensile forces in the belt
- Conveyor design/application environment (can endless splicing be carried out on the conveyor?)
- Cleaning method - Cleaning-in-place (CIP), Cleaning-off-place (COP)

All belts are also available as open roll material or with prepared ends.

	Splice type possible with		
	Fullsan PD	Fullsan CD	Fullsan Flat
 <p>Butt splice (standard)</p>	●	●	●
 <p>Hook fastener</p>	●	●	●
 <p>Plastic rivet</p>	●	●	●
 <p>Clamp fastener (metal)</p>	●	●	●

For splices with mechanical fasteners in CD or PD2 belts needs one lug to be removed completely.

Metal mechanical fasteners cause increased wear on plastic sprockets, thereby such combinations are not recommended.

For minimal drum diameter and the transmittable belt pull contact customer service.

Belt features

Perforations

Belt perforations available for all belt types. Available in various hole diameters and patterns. Contact customer service for examples of row perforations and additional information.

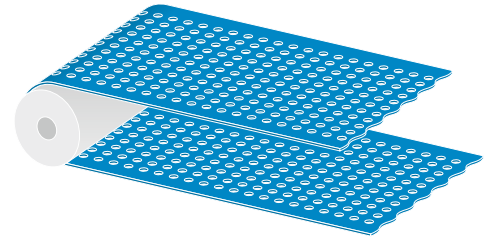

Drive bar removal

Drive bar removal is available for various belts, and applications. Contact customer service for examples and application specific recommendations.

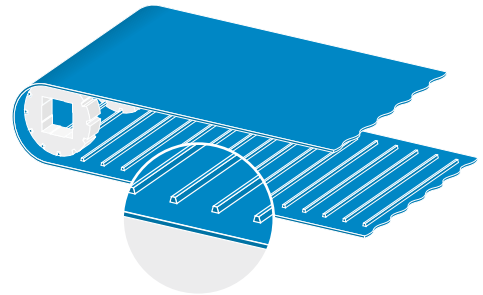

1.2 BELT FABRICATION

Profiles (PU-flights)

- Flights can be welded on belts with small tolerances. individual flight heights are possible. For formfit-driven belts is the splice area between the lugs (Fig. 1).
- Belt in widths of more than 1300 mm (51.18 in) can be equipped if gaps between are applicable.
- Slots can be applied to flights.
- For all open belts with prepared ends for butt splice is a sufficient flight distance necessary, to allow positioning the heating press. The flight distance ist depending on belt type, flight type and heating press.
- Contact our customer service for more information about production tolerances and recommendations of where the belt can be used.
- Flight widths are only possible in a multiple of 10 mm (0.39 in). the minimal width is 50 mm (1.97 in).

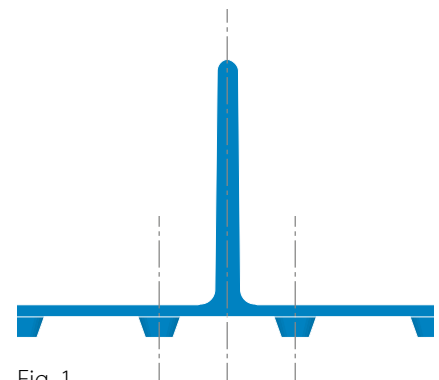
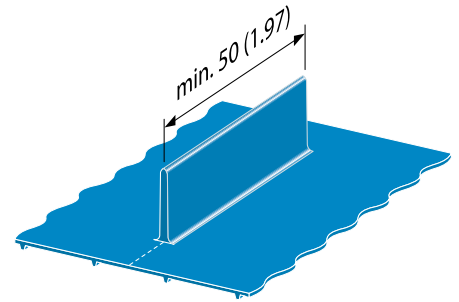
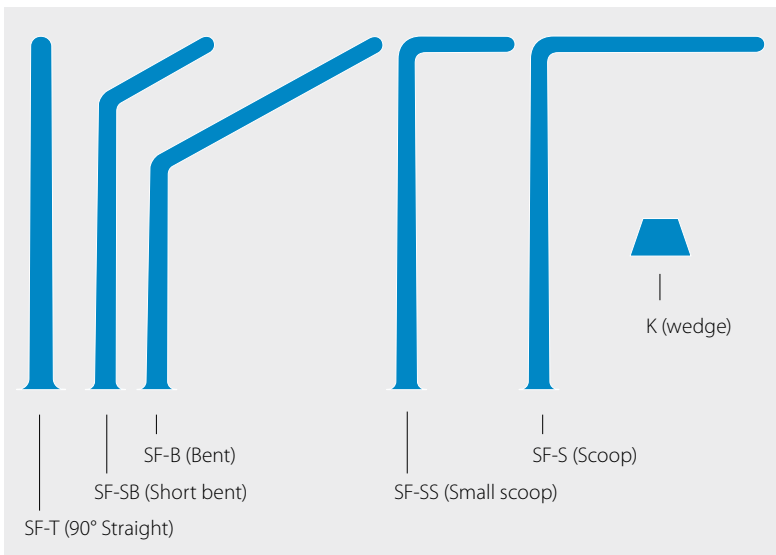

Fig. 1



Profiles (PU top side guides)

- Minimum gap topside guide to flight or sidewall is 12 mm (0.47 in) (see page 20).
- Contact customer service for additional fabrication tolerances, recommendations based on design, and application.

Technical information about PU flights

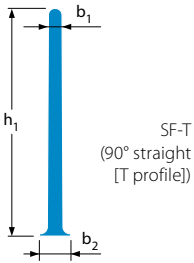

Type designation	Article no.	Height h ₁ [mm (in)]	Height h ₂ [mm (in)]	Thickness b ₁ /b ₂ [mm (in)]	Weight [g/mm (lb/in)]	Extension b ₃ [mm (in)]	Color	Material/surface	d _{min} [mm (in)]*	
									Temp ≥ 0°C/32°F	Temp < 0°C/32°F
SF-T 5X25-U85-GL/GL BL FDA	880730	25 (0.98)	–	4.7/11 (0.19/0.43)	0.159 (0.009)	–	blue	U85 smooth	101 (3.97)	151 (5.94)
SF-T 5X50-U85-GL/GL BL FDA	880731	50 (1.97)	–	4.3/11 (0.17/0.43)	0.306 (0.017)	–	blue	U85 smooth	101 (3.97)	151 (5.94)
SF-T 5X75-U85-GL/GL BL FDA	880732	75 (2.95)	–	4.0/11 (0.16/0.43)	0.442 (0.025)	–	blue	U85 smooth	101 (3.97)	151 (5.94)
SF-T 7X100-U85-GL/GL BL FDA	880733	100 (3.94)	–	6.3/13 (0.25/0.51)	0.867 (0.049)	–	blue	U85 smooth	128 (5.04)	180 (7.09)
SF-T 7X125-U85-GL/GL BL FDA	880734	125 (4.92)	–	6.2/13 (0.24/0.51)	1.069 (0.060)	–	blue	U85 smooth	128 (5.04)	180 (7.09)
SF-T 7X150-U85-GL/GL BL FDA	880736	150 (5.91)	–	6.0/13 (0.24/0.51)	1.268 (0.071)	–	blue	U85 smooth	128 (5.04)	180 (7.09)

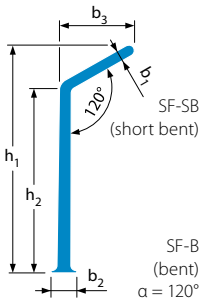

SF-SB 4X50-U85-GL/GL BL FDA	880750	50 (1.97)	379 (1.47)	4.0/10 (0.16/0.39)	0.320 (0.018)	25 (0.98)	blue	U85 smooth	101 (3.97)	151 (5.94)
SF-SB 4X75-U85-GL/GL BL FDA	880751	75 (2.95)	62.9 (2.48)	4.0/10 (0.16/0.39)	0.450 (0.025)	25 (0.98)	blue	U85 smooth	101 (3.97)	151 (5.94)
SF-SB 7X100-U85-GL/GL BL FDA	880752	100 (3.94)	88.7 (3.49)	6.4/13 (0.25/0.51)	0.951 (0.053)	25 (0.98)	blue	U85 smooth	128 (5.04)	180 (7.09)
SF-SB 7X125-U85-GL/GL BL FDA	880753	125 (4.92)	113.7 (4.48)	6.3/13 (0.25/0.51)	1.155 (0.065)	25 (0.98)	blue	U85 smooth	128 (5.04)	180 (7.09)
SF-SB 7X150-U85-GL/GL BL FDA	880755	150 (5.91)	138.7 (5.46)	6.1/13 (0.24/0.51)	1.354 (0.076)	25 (0.98)	blue	U85 smooth	128 (5.04)	180 (7.09)
SF-B 4X75-U85-GL/GL BL FDA	880745	75 (2.95)	48.4 (1.91)	4.0/10 (0.16/0.39)	0.525 (0.029)	50 (1.97)	blue	U85 smooth	101 (3.97)	151 (5.94)
SF-B 7X100-U85-GL/GL BL FDA	880746	100 (3.94)	74.3 (2.93)	6.4/13 (0.25/0.51)	1.077 (0.060)	50 (1.97)	blue	U85 smooth	128 (5.04)	180 (7.09)
SF-B 7X125-U85-GL/GL BL FDA	880748	125 (4.92)	99.3 (3.91)	6.3/13 (0.25/0.51)	1.280 (0.072)	50 (1.97)	blue	U85 smooth	128 (5.04)	180 (7.09)
SF-B 7X150-U85-GL/GL BL FDA	880749	150 (5.91)	124.3 (4.89)	6.1/13 (0.24/0.51)	1.478 (0.083)	50 (1.97)	blue	U85 smooth	128 (5.04)	180 (7.09)

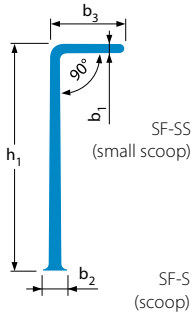

SF-SS 4X50-U85-GL/GL BL FDA	880770	50 (1.97)	–	4.0/10 (0.16/0.39)	0.345 (0.019)	25 (0.98)	blue	U85 smooth	101 (3.97)	151 (5.94)
SF-SS 4X75-U85-GL/GL BL FDA	880771	75 (2.95)	–	4.0/10 (0.16/0.39)	0.475 (0.027)	25 (0.98)	blue	U85 smooth	101 (3.97)	151 (5.94)
SF-SS 7X75-U85-GL/GL BL FDA	880772	75 (2.95)	–	6.6/13 (0.26/0.51)	0.770 (0.043)	25 (0.98)	blue	U85 smooth	128 (5.04)	180 (7.09)
SF-SS 7X100-U85-GL/GL BL FDA	880773	100 (3.94)	–	6.5/13 (0.26/0.51)	0.979 (0.055)	25 (0.98)	blue	U85 smooth	128 (5.04)	180 (7.09)
SF-SS 7X125-U85-GL/GL BL FDA	880774	125 (4.92)	–	6.3/13 (0.25/0.51)	1.184 (0.066)	25 (0.98)	blue	U85 smooth	128 (5.04)	180 (7.09)
SF-SS 7X150-U85-GL/GL BL FDA	880775	150 (5.91)	–	6.2/13 (0.24/0.51)	1.383 (0.077)	25 (0.98)	blue	U85 smooth	128 (5.04)	180 (7.09)
SF-S 4X50-U85-GL/GL BL FDA	880776	50 (1.97)	–	4.0/10 (0.16/0.39)	0.475 (0.027)	50 (1.97)	blue	U85 smooth	101 (3.97)	151 (5.94)
SF-S 4X75-U85-GL/GL BL FDA	880777	75 (2.95)	–	4.0/10 (0.16/0.39)	0.605 (0.034)	50 (1.97)	blue	U85 smooth	101 (3.97)	151 (5.94)
SF-S 7X75-U85-GL/GL BL FDA	880780	75 (2.95)	–	6.6/13 (0.26/0.51)	0.987 (0.055)	50 (1.97)	blue	U85 smooth	128 (5.04)	180 (7.09)
SF-S 7X100-U85-GL/GL BL FDA	880781	100 (3.94)	–	6.4/13 (0.25/0.51)	1.195 (0.067)	50 (1.97)	blue	U85 smooth	128 (5.04)	180 (7.09)
SF-S 7X125-U85-GL/GL BL FDA	880782	125 (4.92)	–	6.3/13 (0.25/0.51)	1.398 (0.078)	50 (1.97)	blue	U85 smooth	128 (5.04)	180 (7.09)
SF-S 7X150-U85-GL/GL BL FDA	880783	150 (5.91)	–	6.2/13 (0.24/0.51)	1.597 (0.089)	50 (1.97)	blue	U85 smooth	128 (5.04)	180 (7.09)

Technical information about PU flights and longitudinal profiles

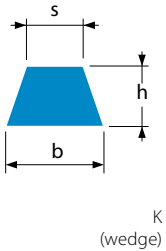

Type designation	Article no.	Dimensions b x h x s [mm (in)]	Color	Material/surface	Permitted operating temp. [°C]	Weight [g/mm (lb/in)]	Flights		Longitudinal profiles		
							Profile spacing min. [mm (in)]	d _{min} approx. [mm (in)]*	Profile spacing min. [mm (in)]	on underside d _{min} approx. [mm (in)]*	on top face d _{min} approx. [mm (in)]*
K6	888009	6x4.2x4 (0.24x0.17x0.16)	blue	U65 smooth	-30/+80	0.022 (0.001)	30 (1.18)	30 (1.18)	30 (1.18)	40 (1.57)	30 (1.18)
K10	880517	10x6x6 (0.39x0.24x0.24)	blue	U65 smooth	-30/+80	0.047 (0.003)	30 (1.18)	50 (1.97)	30 (1.18)	70 (2.76)	60 (2.36)
K13	881233	13x8x7.5 (0.51x0.31x0.30)	blue	U65 smooth	-30/+80	0.078 (0.004)	30 (1.18)	80 (3.15)	30 (1.18)	90 (3.54)	60 (2.36)
K17	888411	17x11x9.5 (0.67x0.43x0.37)	blue	U65 smooth	-30/+80	0.136 (0.008)	30 (1.18)	110 (4.33)	30 (1.18)	90 (3.54)	90 (3.54)

* When establishing the drum diameter, the d_{min} of the belt, flight, and side wall must be allowed for. The highest value is the relevant one and must be no lower. The d_{min} specifications are guidelines. They were established in standard ambient conditions (20°C/50% humidity). Lower temperatures require larger diameters.

1.2 BELT FABRICATION

PU side walls

Side walls can be welded onto the belts in tight tolerances. Customized profile heights are possible. All available side wall types can be used for FLT belts.

- PU side wall material is available in 2 mm (0.08 in) or 2.5 mm (0.10 in) thickness depending on the height of the side wall.
- Side walls must be applied to the belt edges with spacing of at least 5 mm (0.20 in).
- The minimum spacing from long tracking profiles on the belt's top face is 12 mm (0.47 in).
- The minimum distance to flights is 5 mm (0.20 in) – positioning the sidewall in the area of the drive lugs is not possible.
- If sidewalls are used, the belt length has to be a multiple of the sidewall pitch.

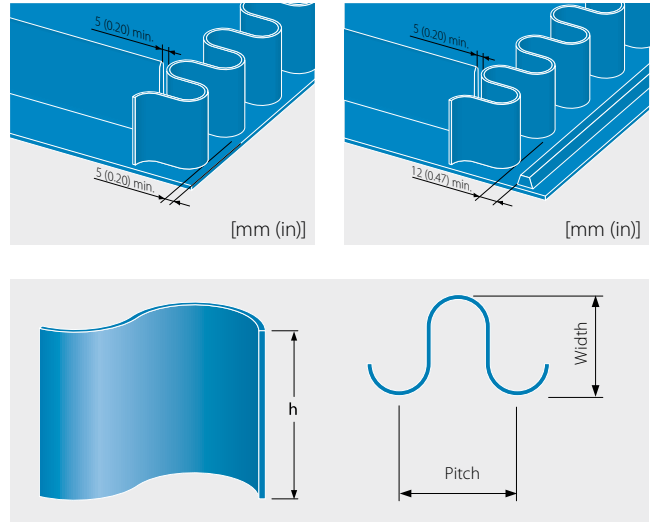

Technical information PU side walls

Type designation	Article no.	Belt type	Height h [mm (in)]	Thickness [mm (in)]	Weight [g/mm (lb/in)]	Pitch [mm (in)]	Width [mm (in)]	Color	Material/surface	d_{min} [mm (in)]*	d_{min} with counter-bending [mm (in)]*
FW 2X 25/P40-U90-GL/GL BL FDA	2880714	FLT/ CD40	25 (0.98)	2 (0.08)	0.235 (0.013)	40 (1.57)	49.5 (1.95)	blue	U90 smooth	80 (3.15)	100 (3.94)
FW 2X 50/P40-U90-GL/GL BL FDA	2880715		50 (1.97)	2 (0.08)	0.470 (0.026)	40 (1.57)	49.5 (1.95)	blue	U90 smooth	100 (3.94)	200 (7.87)
FW 2X 75/P40-U90-GL/GL BL FDA	2880716		75 (2.95)	2 (0.08)	0.705 (0.039)	40 (1.57)	49.5 (1.95)	blue	U90 smooth	130 (5.12)	300 (11.81)
FW 2X 100/P40-U90-GL/GL BL FDA	2880717		100 (3.94)	2 (0.08)	0.940 (0.053)	40 (1.57)	49.5 (1.95)	blue	U90 smooth	160 (6.3)	400 (15.75)
FW 2X 25/P49-U90-GL/GL BL FDA	880714	FLT/ PD2	25 (0.98)	2 (0.08)	0.206 (0.012)	49.5 (1.95)	49.5 (1.95)	blue	U90 smooth	80 (3.15)	100 (3.94)
FW 2X 50/P49-U90-GL/GL BL FDA	880715		50 (1.97)	2 (0.08)	0.411 (0.023)	49.5 (1.95)	49.5 (1.95)	blue	U90 smooth	100 (3.94)	200 (7.87)
FW 2X 75/P49-U90-GL/GL BL FDA	880716		75 (2.95)	2 (0.08)	0.617 (0.035)	49.5 (1.95)	49.5 (1.95)	blue	U90 smooth	130 (5.12)	300 (11.81)
FW 2X 100/P49-U90-GL/GL BL FDA	880717		100 (3.94)	2 (0.08)	1.028 (0.058)	49.5 (1.95)	49.5 (1.95)	blue	U90 smooth	160 (6.3)	400 (15.75)
FW 2.5X 125/P49-U90-GL/GL BL FDA	880720		125 (4.92)	2.5 (0.1)	1.285 (0.072)	49.5 (1.95)	49.5 (1.95)	blue	U90 smooth	210 (8.27)	500 (19.69)
FW 2.5X 150/P49-U90-GL/GL BL FDA	880721		150 (5.91)	2.5 (0.1)	1.541 (0.086)	49.5 (1.95)	49.5 (1.95)	blue	U90 smooth	250 (9.84)	600 (23.62)

* When establishing the drum diameter, the d_{min} of the belt, flight, and side wall must be allowed for. The highest value is the relevant one and must be no lower. The d_{min} specifications are guidelines. They were established in standard ambient conditions (20°C/50% humidity). Lower temperatures require larger diameters.

Detailed dimensions, tolerances, and other specifications available on request. Contact customer service for additional information and recommendations.

Type key PU flights and longitudinal profiles

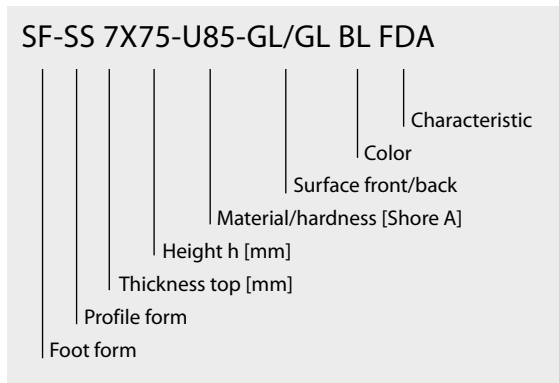

- SF** = Small foot
- B** = Bent
- K** = Wedge profile
- SB** = Short bent
- S** = Scoop
- SS** = Small scoop
- T** = T profile
- U** = polyurethane
- GL** = smooth
- FDA** = food safe compliance with EC/FDA
- BL** = blue

 Blue (RAL 5015)

Type key side walls

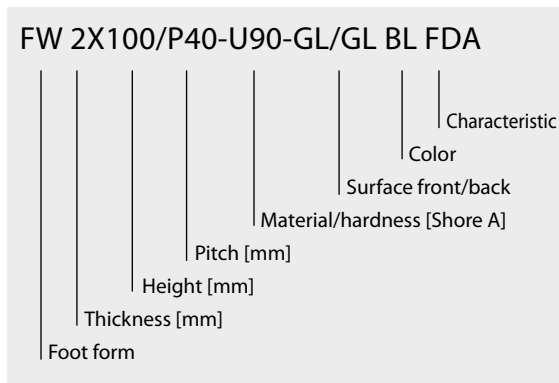

- FW** = footless wall
- P** = pitch
- U** = polyurethane
- GL** = smooth
- BL** = blue
- FDA** = food safe compliance with EC/FDA

 Blue (RAL 5015)

1.3 BELT SELECTION AND SIZING

Which Fullsan type for which application?

Forbo Movement Systems offers various Fullsan versions with or without tension members. They can be supplied with profiles (flights, sidewalls) and other custom configurations to suit various applications. This variability gives you the greatest application engineering benefits.

When selecting a belt, take all relevant factors into account:

- Nature of the transported material (grip, consistency, weight, shape, temperature etc.)
- Process parameters if applicable, e.g. for drying, washing and draining (temperature, pressure, necessary permeability etc.)
- Basic conveyor layout (direction, length, width)
- Drive position and type (form-fitting/friction)
- Belt speed and operating modes (e.g. stop & go, cycling, positioning)
- Spatial conditions at the installation site
- Ambient conditions during operation (temperature, humidity, chemical and mechanical loads)
- Hygiene/cleaning requirements

Belt dimensions may change in operation due to loading and the operating temperature. Take this into account when determining your order data.

Fullsan Positive Drive

Polyurethane belt with homogenous belt body (with or without tension members). Form-fit power transmission via sprockets. Full width drive bars on the underside of the belt.

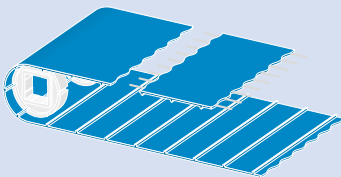

Advantages

- Easy to clean
- High-quality raw material and surface finishing for better hygienic properties
- Hydrolysis- and chemical-resistant
- Food-safe: FDA and EU compliant
- Blue color to provide a contrast to foodstuff
- Smooth running
- Retrofitting of plastic modular belts
- Optional: Reinforced version for heavier loads

Fullsan Center Drive

Polyurethane belt with homogenous belt body (with or without tension members). Form-fit power transmission via sprocket drums. With one centric or depending on width up to three parallel lug rows.

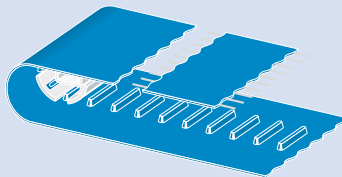

Advantages

- Easy to clean
- High-quality raw material and surface finishing for better hygienic properties
- Hydrolysis- and chemical-resistant
- Food-safe: FDA and EU compliant
- Blue color to provide a contrast to foodstuff
- Self tracking
- Trough conveying on request
- Optional: Reinforced version for heavier loads

Fullsan Flat



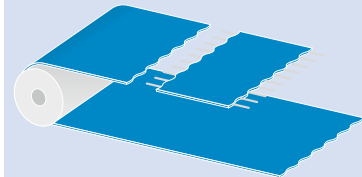

Polyurethane belt with homogenous belt body (with or without tension members). Friction power transmission via a drive drum.



Advantages

- Easy to clean
- High-quality raw material and surface finishing for better hygienic properties
- Hydrolysis- and chemical-resistant
- Food-safe: FDA and EU compliant
- Blue color to provide a contrast to foodstuff
- Trough conveying possible
- Easy tracking properties
- Optional: Reinforced version for heavier loads

Drive types

		Drive type possible with		
		Fullsan PD	Fullsan CD	Fullsan Flat
	Head drive	●	●	●
	Lower head drive	◐	◐	●
	Center drive (e.g. Omega drive)	●	●	●
	Tail drive	○	○	●

- recommendend
- ◐ not recommended
- not suitable

1.3 BELT SELECTION AND SIZING

Pre-tension

Depending on the type and application, Fullsan belts work with different pre-tensions.

Even with low pre-tension, which could be generated by the belt sagging on the return side, it is often advantageous to use a take-up or quick tensioning release take-up (see section 2.2). This makes the belt easy to fit, and provides good control over the belt sag. In addition, it enables fast and convenient cleaning of the belt and conveyor.

The tensioning range (A) should be calculated so that with the take-up extended 30%, no pre-tension is generated, and at least the desired pre-tension can be achieved with the remainder of the travel (fig. 1).

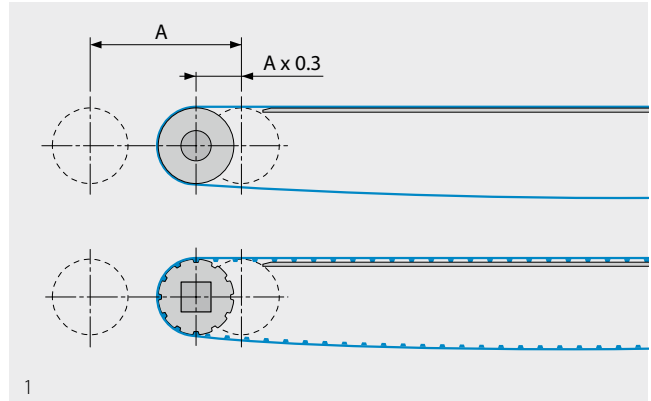

Calculating the required belt length

The required belt length can be determined using the following calculation process (fig. 2):

- Find the total of the individual span lengths in the stretched state. Assume that position-dependent take-ups are extended 30% (a).
- Find the total of the individual arc lengths at all deflection points (b).
- Find the additional required belt length resulting from the desired catenary sag (c) (see section 2.4).
- Add these values and round them if necessary up to a multiple of the tooth pitch.
- Correct the result if necessary taking expected load states into account (belt length and width change depending on the loading).

The calculation formulas for the belt length can be found in section 4.1.

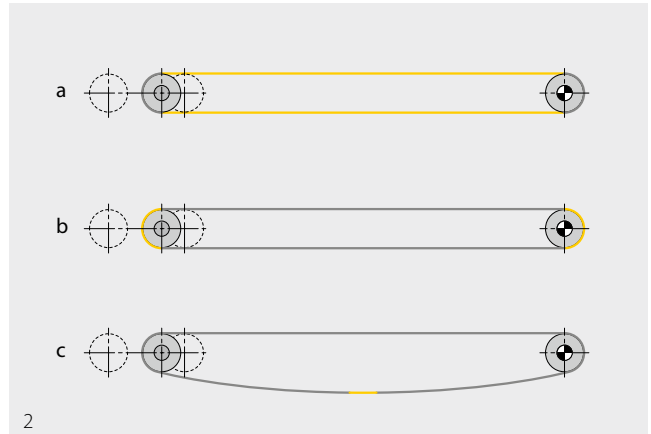

1.4 FACTORS INFLUENCING BELT LIFE

The following diagram shows the basic effects of various influencing factors on the service life of a Fullsan belt.

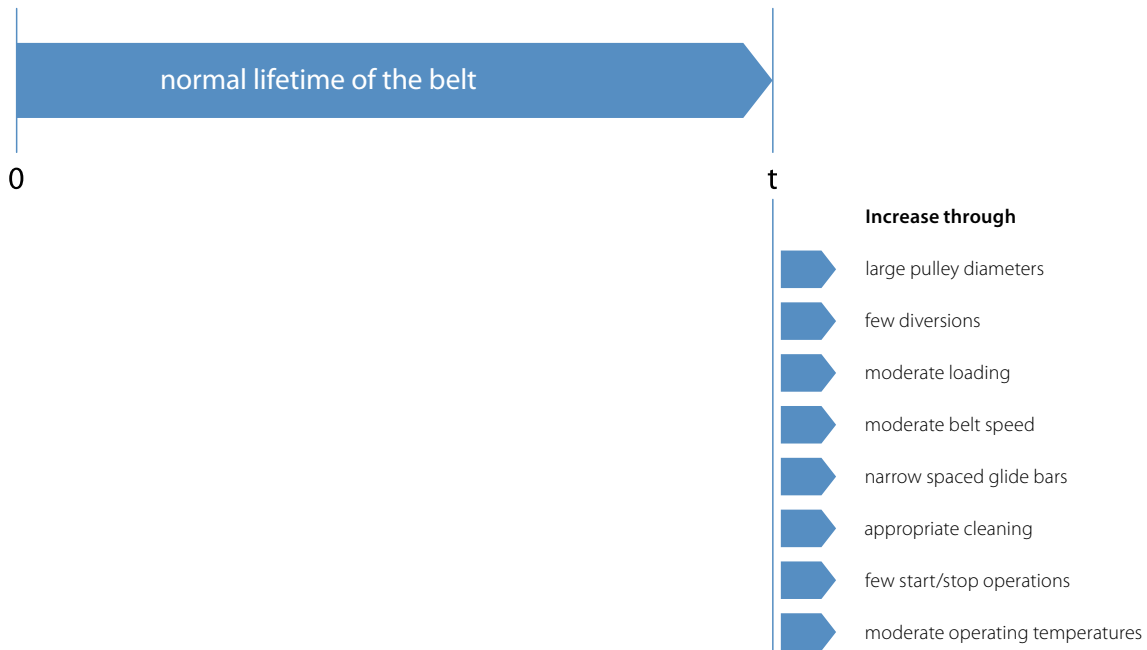

1.5 CLEANING

To achieve optimum cleaning results, coordinate the cleaning process in detail with your cleaning agent supplier and your contact at Forbo Movement Systems.

Follow the steps below to clean:

- 1** Make sure all large particles and residues are removed using scrapers or brushes.
- 2** Rinse with hot water (55–60 °C / 130–140 °F).
Do not use boiling water or extremely high pressure as this will reduce belt life.
- 3** Apply an alkaline cleaning agent to the belt surfaces that has been approved by your plant sanitarian, sanitary operation procedures, or cleaning chemical supplier.
- 4** Rinse the belt with hot water (55–60 °C / 130–140 °F).
Do not use boiling water or extremely high pressure as this will reduce belt life.
- 5** Disinfect with a disinfectant that has been approved by your plant sanitarian, sanitary operation procedures, or cleaning chemical supplier.
- 6** Rinse the belt with hot water (55–60 °C / 130–140 °F).
Do not use boiling water or extremely high pressure as this will reduce belt life.

Notes:

- Water pressure should not exceed 17 bar (250 psi), to avoid aerosol contamination.
- Maintain a safe distance between belt and water nozzle.
- Water temperature should not exceed 65 °C (150 °F), to avoid proteins sticking to the belt surface, as well as for safety reasons.
- Do not exceed the specified concentration or temperature for the cleaning agent. Please refer to your plant sanitarian, sanitary operation procedures, or cleaning chemical supplier for proper use of and recommended chemicals for your specific needs.

Our TecInfo 09 also offers you a detailed description. Please inquire.

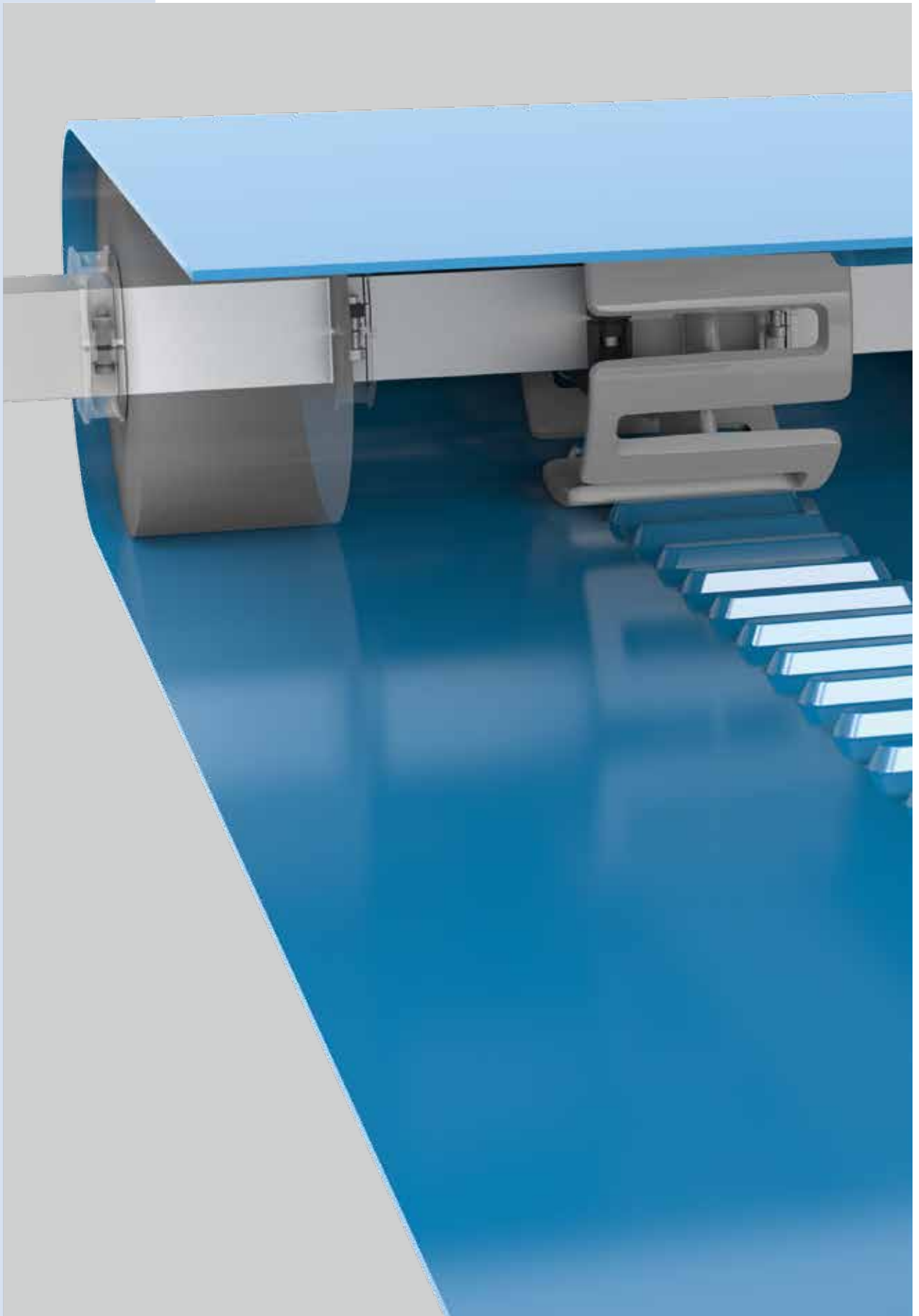

2 CONVEYOR DESIGN

Many conveyor design principles are identical for all Fullsan series, and are therefore dealt with together.

But drives, pulleys and belt tracking systems differ from each other in many respects, so they are described separately for each Fullsan series.

- 2.1 General
- 2.2 Notes on conveyor construction
- 2.3 Belt support on the carrying side
- 2.4 Belt support on the return side
- 2.5 Fullsan Positive Drive
Drive | Pulleys | Tracking
- 2.6 Fullsan Center Drive
Drive | Pulleys | Tracking
- 2.7 Fullsan Flat
Drive | Pulleys | Tracking

2.1 GENERAL

Conveyor components

Conveyors may differ considerably from the diagram shown here due to different drive types and layouts.

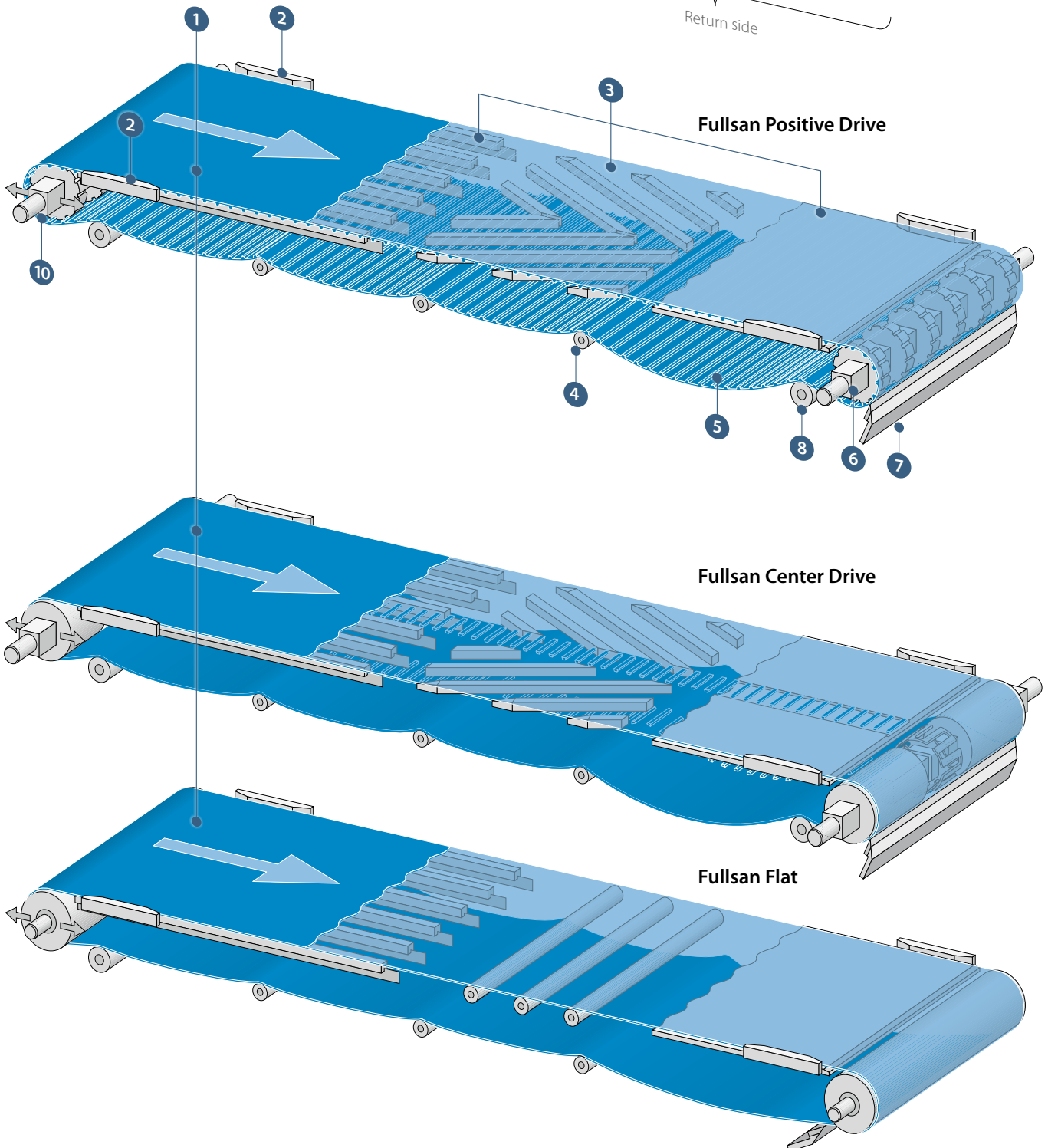
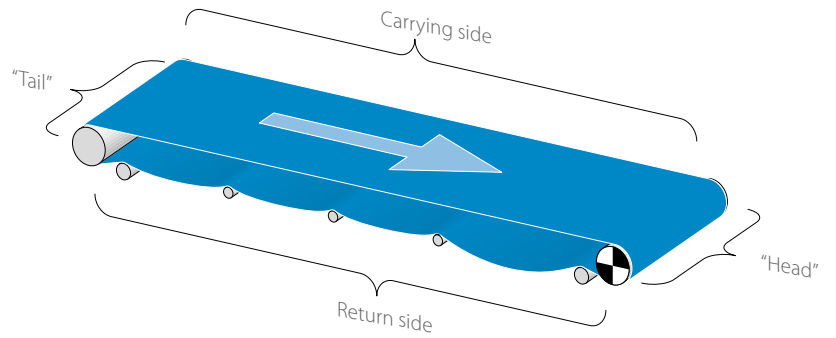

1 Fullsan homogenous belts (PD, CD, Flat series)

Conveyor carrying side

- 2 Guide rails to guide the belt at the sides
- 3 Different types of belt supports

Conveyor return side

- 4 Return rollers (if necessary with flanged pulleys to guide the sides of the belt)
- 5 Belt sag

“Head” of the conveyor (outfeed)

- 6 Drive shaft/drum (at the “head” of the conveyor)
- 7 Scraper
- 8 Snub roller
- 9 Pressure roller

“Tail” of the conveyor (infeed)

- 10 Idler shaft/drum (at the “tail” of the conveyor, optionally designed as a take-up)

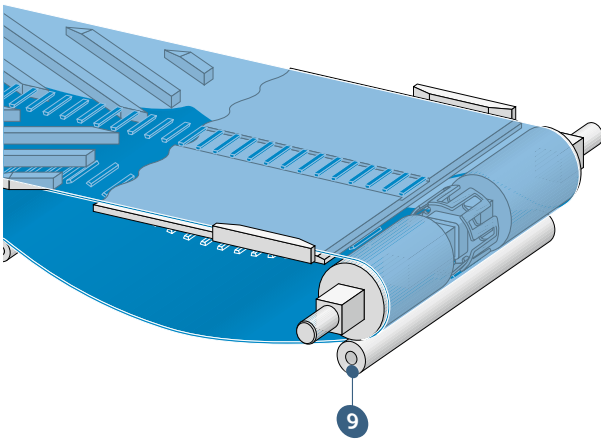

2.1 GENERAL

Hygienic design

Fullsan belts are very often used in applications where high hygiene standards have to be maintained. The system as a whole can only meet these standards in conjunction with an adequate conveyor design.

Where high hygiene standards are required, conveyor systems and conveyors have to be constructed according to design principles that avoid relevant design weaknesses. Dirt must not build up; materials, surfaces and components should be easy to clean.

Therefore, in these cases, bear the following principles in mind:

- Keep the overall design as simple as possible to avoid dirt traps.
- Use as many supports as structurally necessary.
- Avoid using mechanical belt splices whenever possible.
- Avoid using tubes that are not completely sealed. Instead use solid bars wherever possible.
- L and U sections as well as surfaces should be positioned so that liquids reliably run off them.
- For the joining technology, give preference to clean welded joints (welded seams in contact with food should be ground/cut flat).
- If bolted connections are unavoidable, do not leave any thread sections exposed; do not use star washers as clamping elements and do not use Allen screws. All joint areas should be easy to clean.
- If possible, do not design inside radii smaller than 3 mm (0.12 in).
- Never drill into completely sealed tube sections, not even to create internal threads, e.g. for adjustable feet.
- Design for easy tool-free installation and removal of accessory parts, e.g. belt guides.
- Finish all surfaces that are in direct contact with food in accordance with relevant food hygiene regulations (grind, polish, passivate, ...)
- Use only materials that are easy to clean and resistant to frequent cleaning, and are food safe where applicable. Note the materials table on the next page.

Detailed information about hygienic design requirements and hygienic operation can be found in the publications of the European Hygienic Engineering & Design Group (EHEDG) | www.ehedg.org

In addition to the requirements listed here, the further sections on conveyor design should also be taken into account whenever Fullsan is used.

Materials

All materials used in the conveyor must satisfy hygienic and mechanical requirements, withstand the corresponding operating conditions, and where applicable be correct friction partners in interaction with the conveyor belt.

Therefore, for the selection and type of materials, it is essential to observe the recommendations in the following table. During use, also note the expansion/contraction of the respective materials due to temperature.

Conveyor components	Materials
Frame	Aluminium Steel Stainless steel
Sliding support	Ultra-high-molecular-weight Polyethylene (UHMW-PE)
Drum	Steel Stainless steel
Scraper	Polyurethane (PU)
Side strips	Ultra-high-molecular-weight Polyethylene (UHMW-PE)
Side skirts	Polyurethane, solid (PUR)

Please contact our customer service team if you have any questions.

2.2 NOTES ON CONVEYOR CONSTRUCTION

Frame and supports

The following aspects should be taken into account in the design:

- For cleaning, maintenance and repair purposes, all parts of the conveyor must be easily accessible. Use simple structures that allow the belt to be lifted up and/or drive/idler rollers to be easily removed (e.g. swing open designs).
 - For easy belt installation as well as quick and convenient cleaning, take-ups and/or quick-tensioning devices may also be useful even if the belt is operated without pre-tension.
 - Match the conveyor design to the selected belt type. All pulley diameters, transitions etc. should have at least the allowed d_{min} of the belt (for wrap angles $\leq 15^\circ$ also $d_{min}/2$). Also pay attention to counter-bending and the space requirements e.g. of profiles (flights, sidewalls) etc. Profiles (flights, sidewalls) may require a greater drum diameter than the belt type on its own (see section 1).
 - If the design makes it difficult to fit preassembled belts, then it has to be possible to make the belts endless on the conveyor. Alternatively, mechanical belt fasteners can be used if the application permits.
 - The spatial conditions at the installation site must allow all planned conveyor functions.
- A catenary sag in the bottom run should normally be provided for positive driven belts (Positive Drive and Center Drive). It can only be omitted with relatively short belts that are fitted with a pre-tension of not more than 0.3%.
 - For all conveyor dimensions, note the belt elongation and shrinkage that can occur during operation. Low temperatures must not result in excessive shaft loads (due to shrinkage) and at high temperatures lengthening must be accounted for to ensure appropriate transmission of drive power (see materials table in section 2.1).
 - When designing the belt support in the bottom run, take into account the weight, length and position of the belt sagging that can occur depending on temperature. It is important that e.g. fastening elements, cables and collection trays do not touch the belt in any operating state.

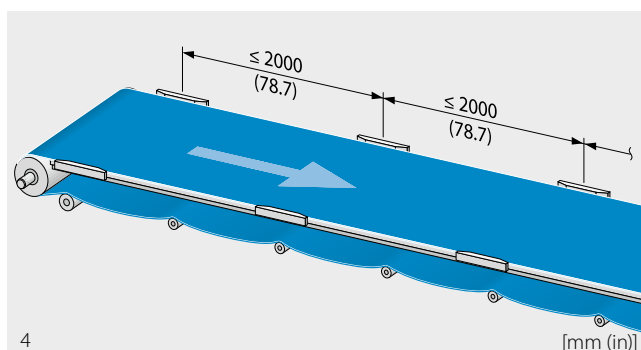
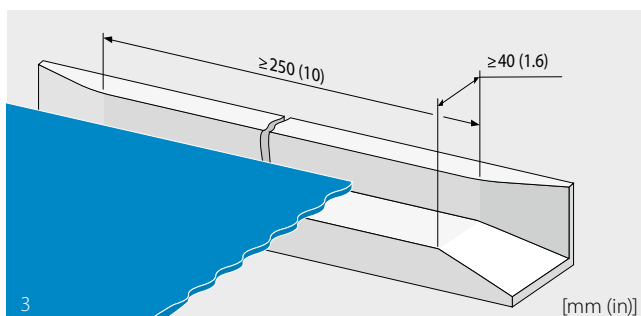
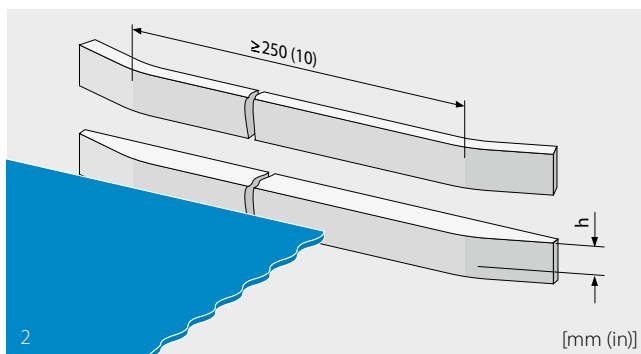
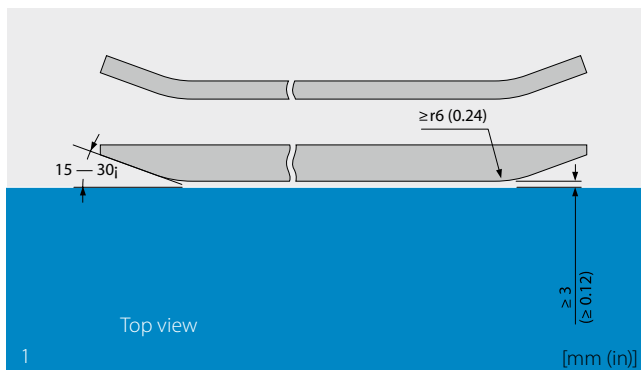

Belt side guides

If required, Fullsan belts can be guided at the belt edges. With the Fullsan Center Drive type, one or more rows of drive lugs ensure perfect tracking. Do not use these belt guides to compensate for poor belt tracking (if necessary, correct the belt tracking as described in sections 2.5/2.6/2.7).

- Use only the materials specified in section 2.1 with the corresponding surface finish to minimise abrasion and drag where applicable to meet hygienic requirements.
- At the greatest width that the belt reaches under the given operating conditions, the gap at the side from guide components must be at least 3 mm (0.12 in) (fig. 1, top view).
- Use either guide blocks or flange rollers (main dimensions see figures 1–4). Place the first guide components close to the end pulley; the next ones at intervals of no more than 2000 mm (78.7 in) towards the drive. Use long side guides or L-shaped supports in the area of infeeds and outfeeds.
- During installation, make sure fastening elements do not rub against the belt (use countersunk headscrews) and that hygiene requirements are observed. All guide surfaces should be accurately aligned in the conveyor direction and perpendicular to the conveyor path.

Support on the underside of the belt is provided by wearstrips, flat supports or rollers. See section 2.4.

2.2 NOTES ON CONVEYOR CONSTRUCTION

Conveyor speed

We recommend a soft start and soft stop for the motor for speeds of more than 20 m/min (65 ft/min), or for loads greater than 70% of the max. load. High conveyor speed negatively effects the service life of the belt.

Conveyor length

The maximum conveyor length is generally limited by the belt's maximum tensile strength, but it can also be limited by the effects of elastic oscillation, which should in principle be avoided. This can occur when the belt stretches under load and causes a slip-stick effect. The slip-stick-effect describes the effect of the belt alternating between sliding over and sticking to the slider bed.

The determining factors to avoid the slip-stick effect are belt length, belt speed, loading, and friction. In general, the higher the speed and the shorter the conveyor, the lower the risk of slip-stick.

Expansion/contraction due to temperature

Plastics can expand or contract significantly with variations in temperature.

- Make allowances for possible changes in the belt length and width that occur when the operating temperature deviates from the original ambient temperature. This applies both to the belt sag on the return side and lateral clearance on the conveyor frame.
- Components such as guide rails and wearstrips also change size depending on the temperature. Take this into account for assembly (e.g. by providing elongated holes, fixing at only one point, placing slotted parts on sheet metal edges, etc.) Easy to clean gaps should be allowed between adjacent parts.
- Remember that components and the belt expand at the same time, so gaps between them may become smaller from both sides due to temperature changes.

Materials recommended by Forbo Movement Systems for various conveyor components are listed in the materials table in section 2.1.

Take-ups

The belt contact pressure on the drive drum that Fullsan Flat requires to transmit the circumferential force is generated by a take-up that tensions the belt (fig. 1).

Even if no pre-tensioning is required (normally with Fullsan Positive Drive and Fullsan Center Drive), it can be helpful to use a take-up, because:

- it can make it easier to fit and remove the belt
- it simplifies and speeds up cleaning processes
- it can compensate for temperature and load-dependent belt lengthening, and if necessary control belt sag

Usually position-dependent take-ups are used. In this case, a pulley is fitted that is adjustable in the conveyor direction (e.g. by screws). It can be moved parallel to the axis to apply the desired pre-tension or generate the desired belt sag.

The tensioning range should be calculated so that with the tensioning travel extended 30%, no pre-tension is generated, and at least the desired pre-tension can be achieved by extending the take-up system out further.

Force-dependent tensioning can be achieved e.g. by means of a weight load acting via a cable. Alternatively, pneumatic, hydraulic or spring-loaded take-ups can be used.

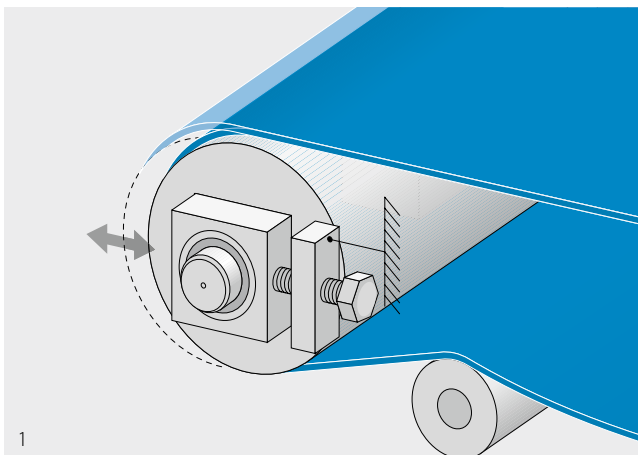

Quick release tensioning devices

Unlike adjustable take-ups, pure quick-action tensioning devices do not allow precise adjustment of the tension and belt sag (fig. 2).

Locking swing-open designs are common here. One end of the conveyor frame (including the pulley) is designed to swing up via an axis-parallel pivot axis. Swinging the device up completely slackens the belt and forms a large sag. This makes it much easier and faster to clean the belt and conveyor.

Once closed, the belt is correctly tensioned and in the right position again.

Of course it is possible and often useful to combine this with a take-up.

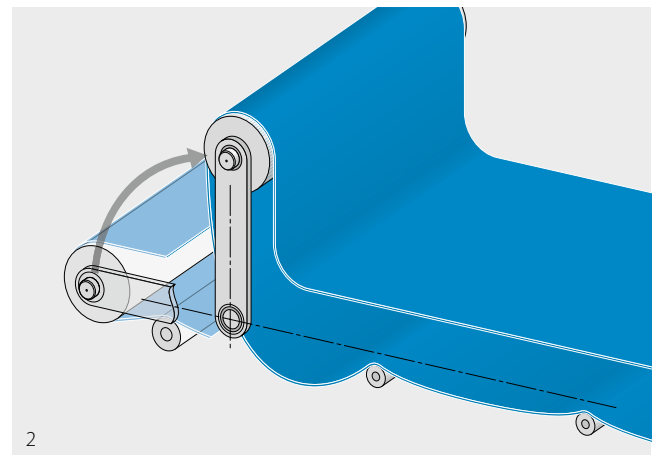

2.2 NOTES ON CONVEYOR CONSTRUCTION

Scrapers

Often one or more scrapers are sufficient to clean adhering transported material from the belt during operation. To ensure trouble-free operation, calculations should include an extra allowance for drive power.

- The scraper material should be well matched to the belt and transported material to prevent unnecessary wear on the belt surface and achieve effective cleaning performance.
- The best results are normally achieved with co-extruded scrapers that have a relatively soft scraper lip and rigid main body. They are recommended for hygiene reasons due to their homogenous structure.
- Scraper to be mounted on cross rigid structure (minimizing bending/deflections) supported by the conveyor frame.
- Scraper should be installed as shown with light contact to the belt. If necessary, observe the position of the sprocket during assembly. The sprocket must be turned so that the belt is supported by a raised area of the sprocket (figs. 1/2).
- Set the angle of the scraper according to the drawing (do not fit at 90° to the belt).
- Provide adjustment devices to compensate for wear in the scraper strip.
- Readjust or replace worn scrapers. Damaged scrapers should also be replaced to prevent belt damage.
- Make sure that the belt is flat in the transverse direction at the scraper position (e.g. check the small clearance between the sprocket/roller and the scraper at the relevant axis) and does not change its position due to changes in belt sag.

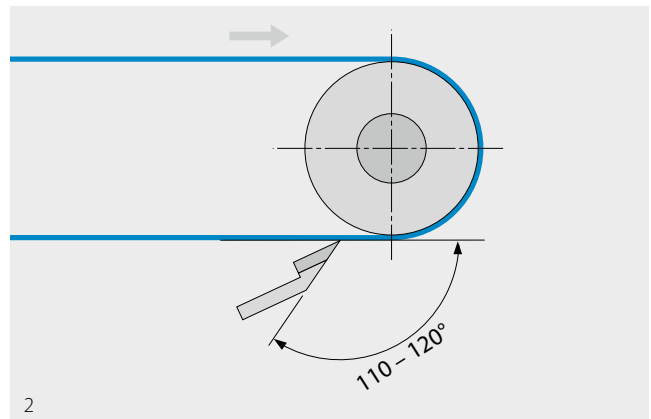
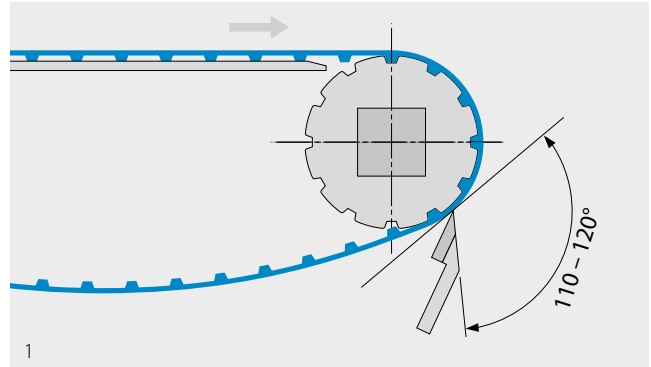

Only for Fullsan Flat:

- On the bottom run, so-called plough deflectors are often used before the end deflector to prevent falling transported material coming between the belt and drum. They should only lightly touch the belt (fig. 3).
- Smooth drums without a lagging can be kept clean by steel scrapers. These scrapers can be positioned close against the drum surface and modified for the ring shape (e.g. trapezoid shape).

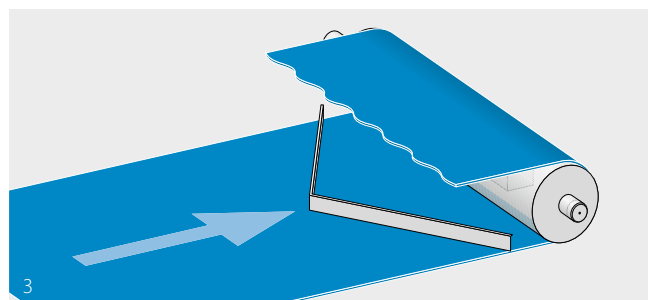

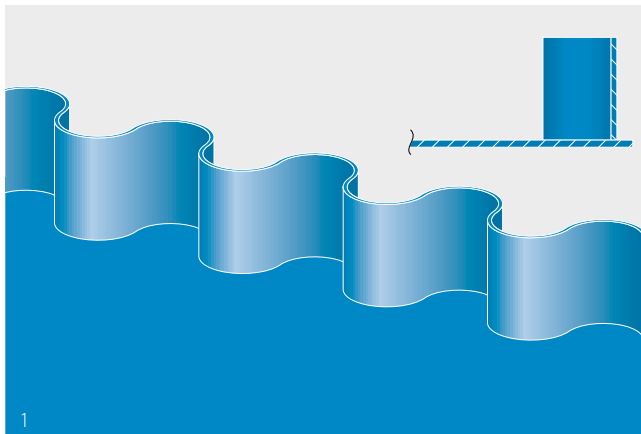

Side limits

Sidewalls

Encapsulating the product on the sides can be achieved with sidewalls (fig. 1).

- Provide sufficient clearance from other conveyor components to avoid contact.
- Note that in the concave curve (on angle conveyors), the waves are compressed at the top edge and become wider across the conveyor direction.

Available sidewalls are listed in section 1.2.

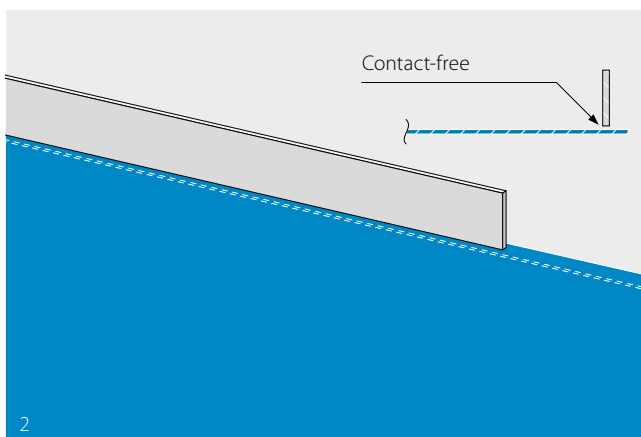

Side strips

Side strips are lateral guides for the transported material (fig. 2). They should open in the direction of belt travel (towards the outfeed end) to prevent transported material getting trapped between the sealing guide (strip) and belt.

- Fit sealing guides at right angles to the belt and only as close to the belt as the transported material requires.

For material recommendations see the materials table in section 2.1.

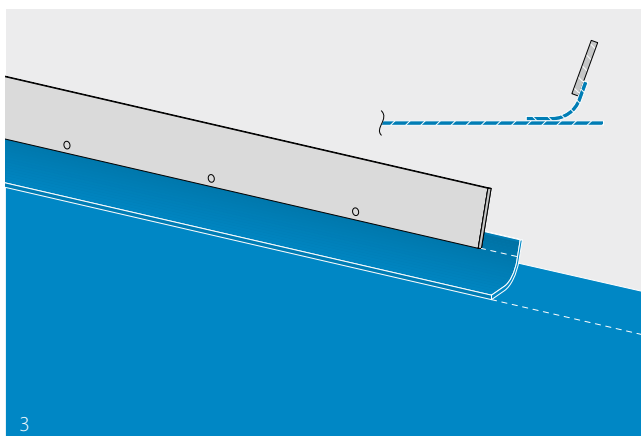

Side skirts

Side skirts drag on the belt and can be used for lightweight transported material (fig. 3).

This can cause increased wear on the carrying side of the belt. Profiles (flights) may need to be moved inwards to make room for them.

For material recommendations see the materials table in section 2.1 or consult your Forbo Movement Systems sales representative for side skirt material solutions.

2.2 NOTES ON CONVEYOR CONSTRUCTION

Feeding the transported material

During loading, the conveyor belt is stressed in the vertical (impact) and tangential directions.

You should therefore provide devices that deliver the transported material to the conveyor belt with low impact energy and a speed component in the belt running direction (ideally at the same speed) (fig. 1). Loading should take place centrally to prevent deflection of the belt (material fed e.g. by chutes, guide plates, hoppers, feed silos).

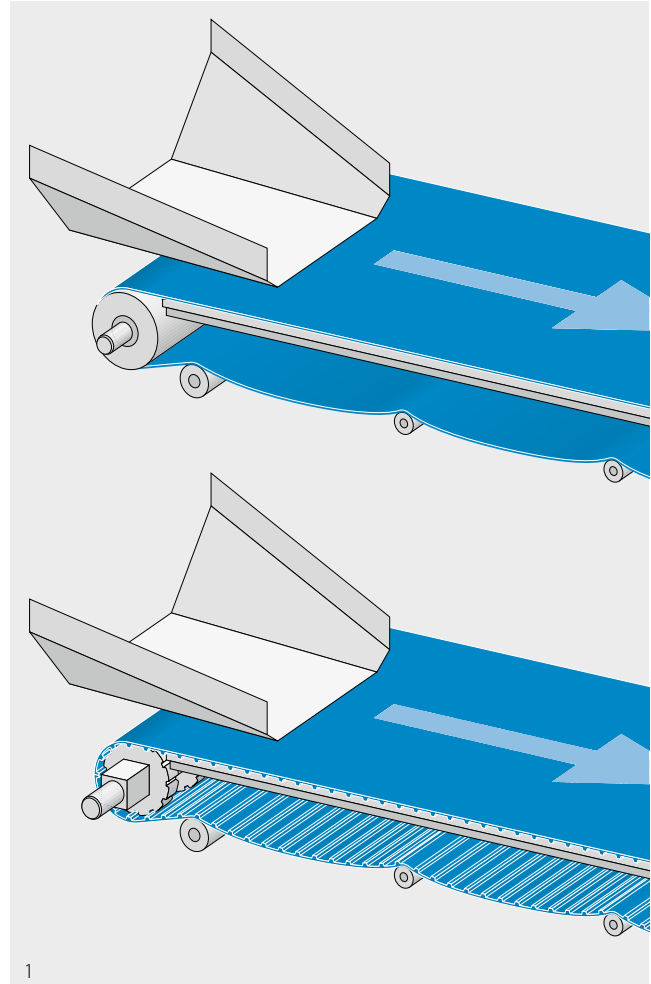

Designing axes and shafts

Shaft profiles

For form-fit drive with Fullsan PD and Fullsan CD, we recommend using square shafts. They have the advantage that positive drive and tracking are possible without keys and keyways. This can save on manufacturing costs. Occasionally round shafts with feather keys are used for narrow belts with light loads. Specially designed sprockets with bore and keyway are also available (fig. 2).

Further information on the sprockets can be found in Section 1.1.

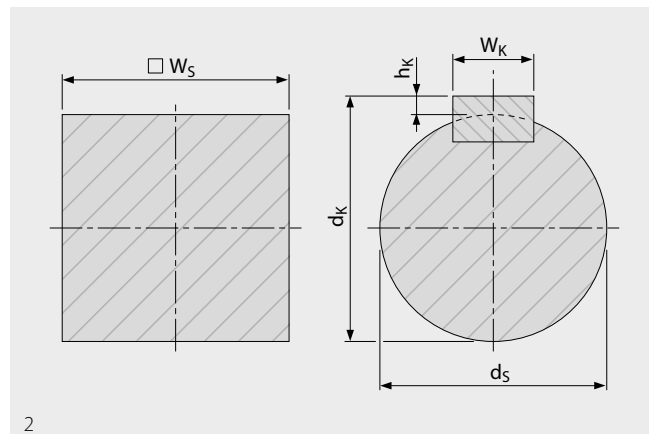

Deflection of shafts, axes, drums, and rollers (fig. 1/2)

The belt pull acting on axes and shafts causes deflection. Large bearing distances and small diameters amplify this effect.

- Keep deflection as small as possible to minimize material fatigue and ensure a small, uniform transfer gap (we recommend keeping the deflection value ≤ 2 mm).
- If the belt pull causes greater deflection (> 2 mm), change the dimensioning accordingly or use an intermediate bearing.

The calculation formulas for the shaft deflection can be found in section 4.1.

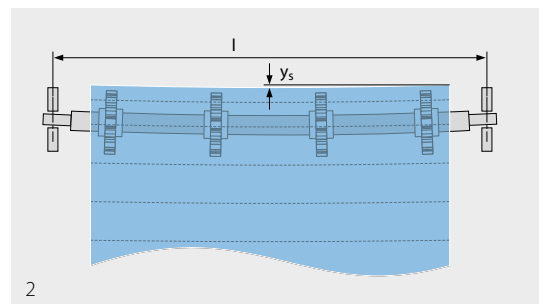
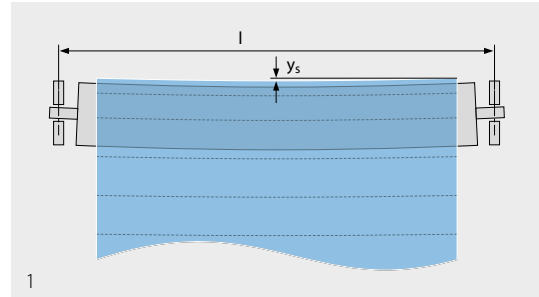

Shaft torsion (fig. 3)

Because of the belt pull, shafts twist when transmitting torque, from the drive end to the sprocket farthest away. Long and thin shafts as well as high tensile forces and large sprockets amplify this effect.

If the shaft twists too much, the teeth will not engage correctly. We recommend keeping a torsion angle φ (phi) of $< 0.25^\circ$ per metre of shaft length.

The calculation formulas for the shaft torsion can be found in section 4.1.

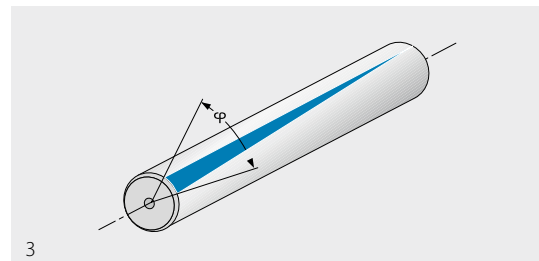

2.2 NOTES ON CONVEYOR CONSTRUCTION

Sprockets

- Select sprockets compatible with belt type.
- Select sprocket size compatible with belt minimum pulley diameter. For belts with fabrication choose size based on largest minimum pulley diameter.
- For applications with heavy loads consider stacked sprockets or full face with sprockets.
- It is recommended to lock down all sprockets.
- Contact customer service for additional information and recommendations.

For further drive type specific information see section 2.5 "Fullsan Positive Drive" and section 2.6 "Fullsan Center Drive".

Available Sprockets see section 1.1 "Technical Data".

2.3 BELT SUPPORT ON THE CARRYING SIDE

General

When designing the belt support, also note the general information in section 1.1 and, where applicable, the notes on hygienic design in section 2.1.

- Always precisely align the slide supports, as these have a very strong guiding effect on the belt.
- Position the slide supports as shown in the drawings.
- For the slide support, use only the materials listed in section 1.1. These materials produce favorable friction characteristics.
- Thoroughly clean the slide supports before putting the conveyor into service. Otherwise residues of protective paints or other contamination could cause significant problems (e.g. tracking issues, belt damage, increased friction on the running side).
- Consult your contact person at Forbo Movement Systems if particularly heavy materials are to be transported and high point loads occur.

Supporting the belt with flat (table) supports

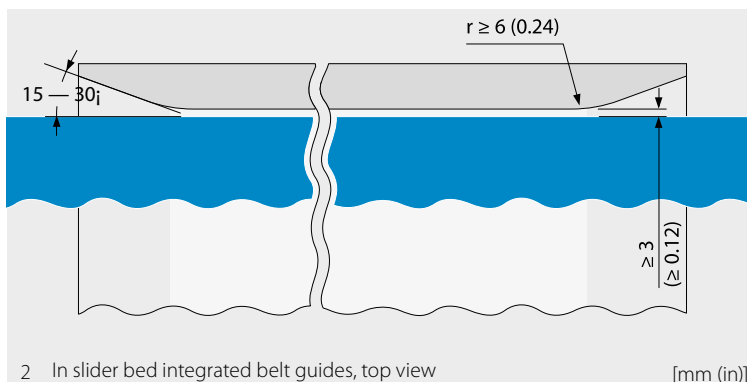
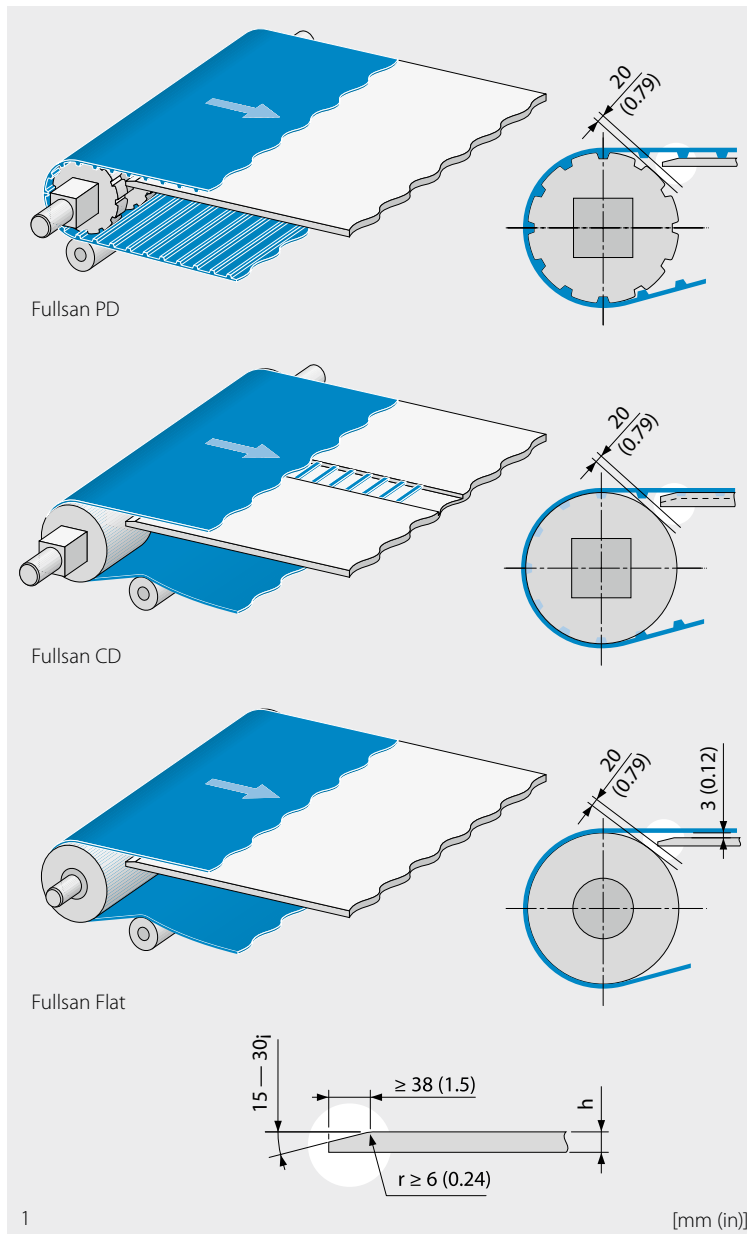

Full-surface table supports are recommended for systems with heavy loads (fig. 1).

- Use only materials according to the specifications in the materials table in section 2.1.
- Carefully round off edges and slightly chamfer sliding surfaces in the conveyor direction.
- The thickness “h” should be at least large enough to allow fastening elements such as screw heads to be completely countersunk, and so that the chamfer in the conveyor direction can be formed.
In addition, the thickness is determined by the static requirements.
- Fastening elements must not make contact with the belt.

The design is dependent on the belt type used and the conveying task. For better hygiene the slider bed and side guides can be designed out of one piece (figs. 2/3).

When designing the drive and idler pulley area, observe the notes for the Fullsan series used (section 2.5, 2.6 or 2.7).

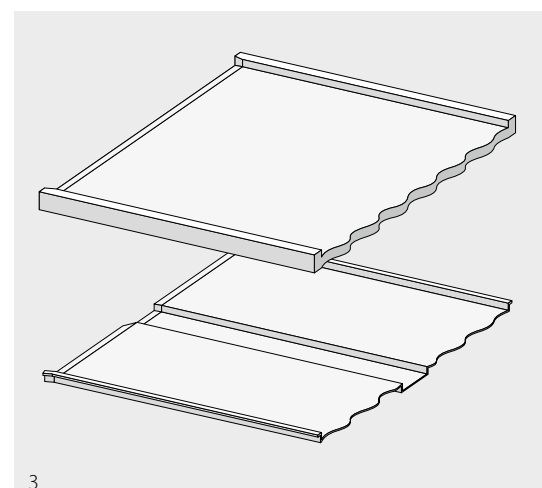

2.3 BELT SUPPORT ON THE CARRYING SIDE

Supporting the belt with parallel wearstrips

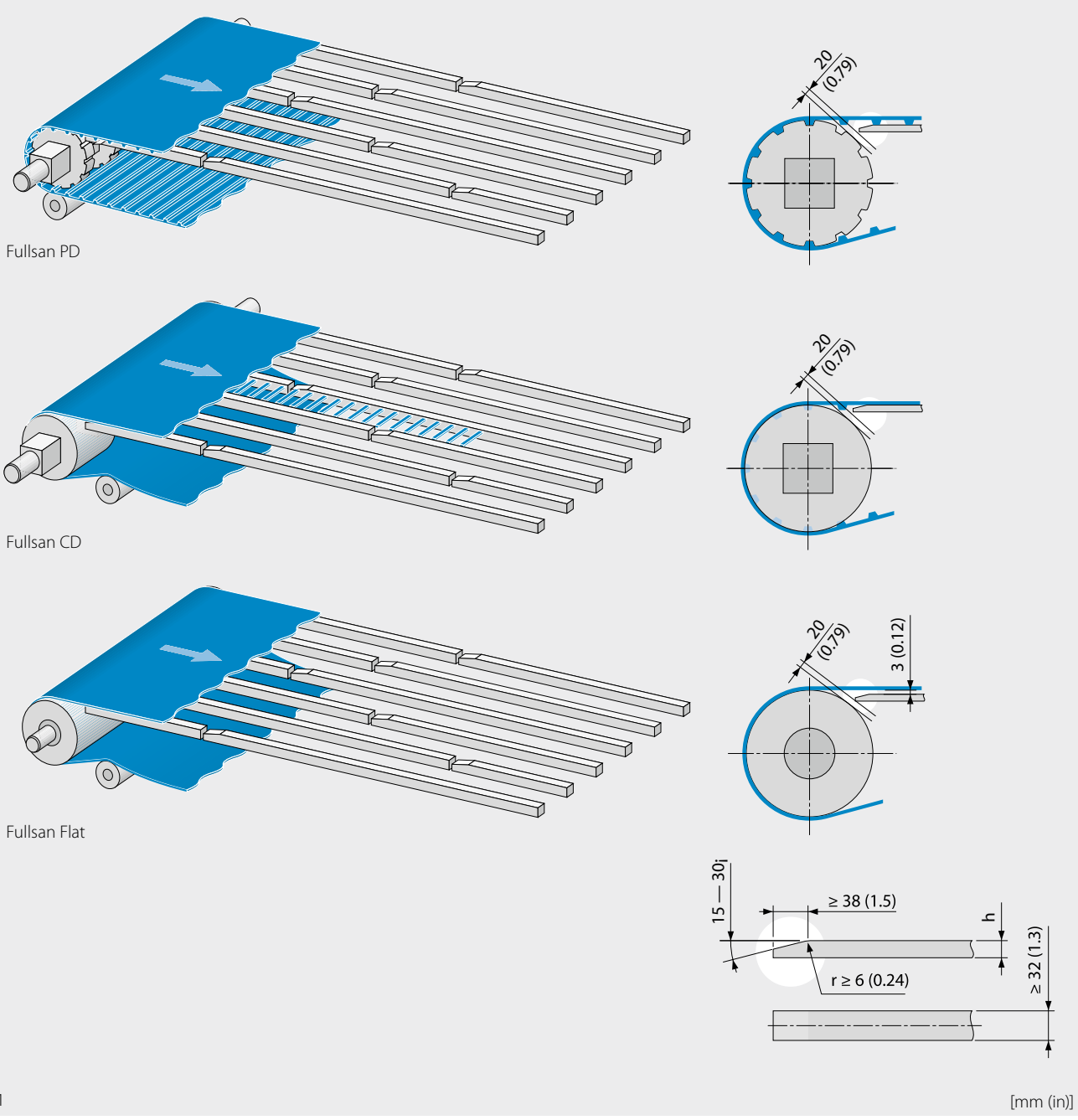

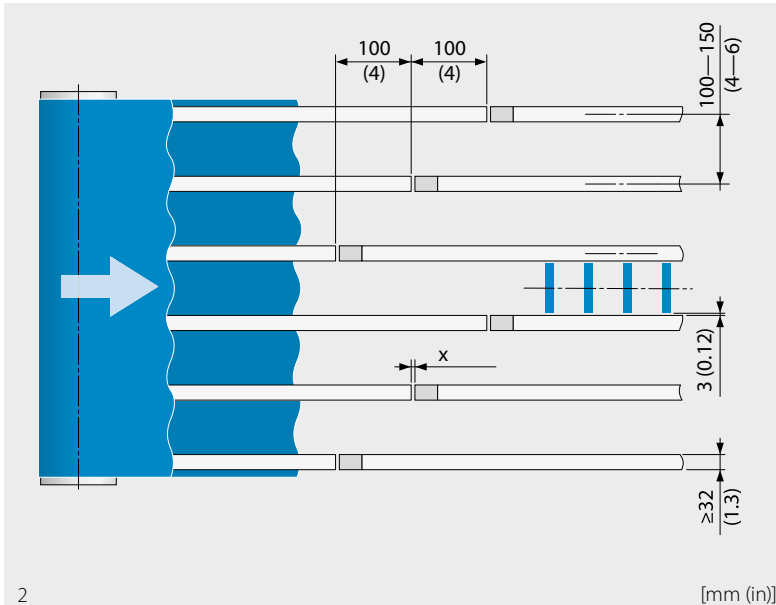

For applications with light loads, parallel wearstrips can be used (fig. 1, left page). Note in this case that the underside of the belt is subject to increased wear in the area of the wearstrips.

- Use only materials according to the specifications in the materials table in section 2.1.
- See the figures 1 and 2 for the main dimensions of wearstrips and their positioning.
- The thickness “h” should be at least large enough to allow fastening elements such as screw heads to be completely countersunk, and so that the chamfer in the conveyor direction can be formed. (Specifications for plastic material.)
In addition, the thickness is determined by the static requirements.
- The sliding surface must be flat and aligned in two directions with the belt run.
- Carefully round off edges and slightly chamfer sliding surfaces in the conveyor direction.
- Fastening elements must not make contact with the belt.

- Stagger the joints of the wearstrip sections in the conveyor direction. A gap must be provided between the individual sections in the conveyor direction (dimension “x”) that can accommodate length changes due to temperature fluctuations and be cleaned easily.
- Check whether sections with flat (full surface) support are appropriate in the transported material infeed area.
- Fullsan Center Drive belts can be guided by pairs of wearstrips next to the teeth.

When designing the drive and idler pulley area, observe the notes for the Fullsan series used (section 2.5, 2.6 or 2.7).

2.3 BELT SUPPORT ON THE CARRYING SIDE

Supporting the belt with a V-shaped arrangement of wearstrips

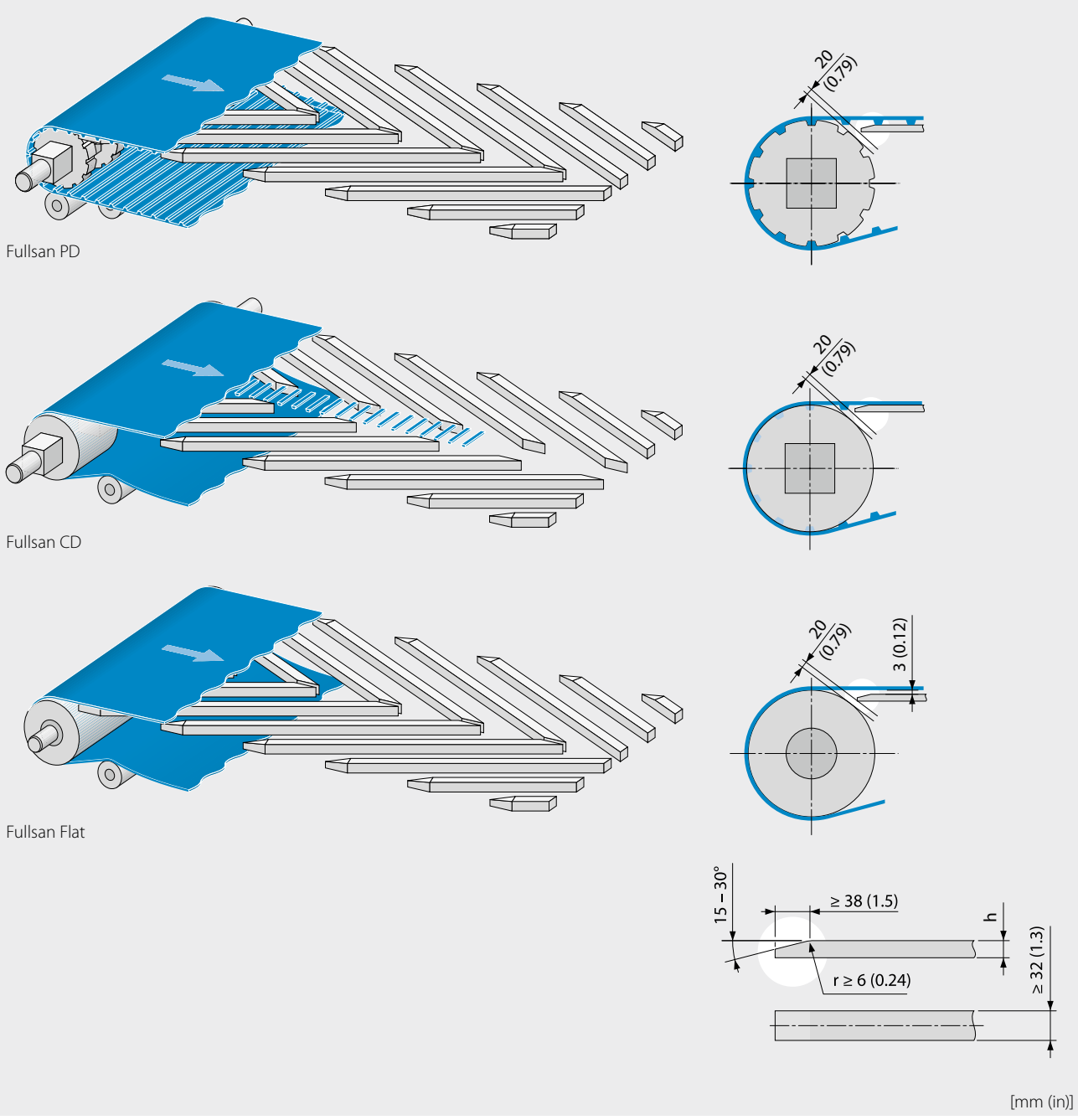

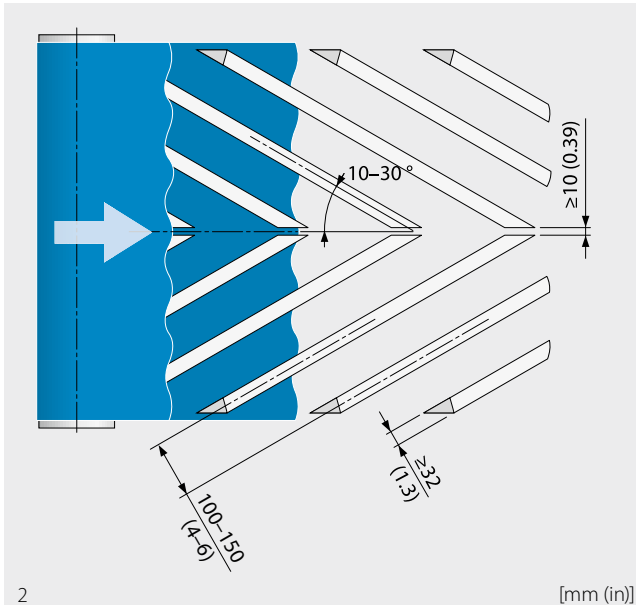

With a V-shaped arrangement of wearstrips, the belt is supported across its full width (fig. 1, left page). This results in even wear across the belt width, which means that heavier loads are possible. At the same time, contaminating particles can be wiped off the belt underside.

- Use only materials according to the specifications in the materials table in section 2.1.
- Select the angle and spacing so that the individual V-shapes reach into one another and support the belt across the full width.
- See the figures 1 and 2 for the main dimensions of wearstrips and their positioning.
- The thickness “h” should be at least large enough to allow fastening elements such as screw heads to be completely countersunk, and so that the chamfer in the conveyor direction can be formed. (Specifications for plastic material.)
In addition, the thickness is determined by the static requirements.

- Carefully round off edges and slightly chamfer sliding surfaces in the conveyor direction.
- Fastening elements must not make contact with the belt.
- Fullsan Center Drive belts can be guided at the sides by pairs of wearstrips.

When designing the drive and idler pulley area, observe the notes for the Fullsan series used (section 2.5, 2.6 or 2.7).

2.3 BELT SUPPORT ON THE CARRYING SIDE

Supporting the belt with rollers

Forbo Movement Systems recommends roller supports only for Fullsan Flat. Troughed conveyors are an exception (see section 3).

For conveying unit goods, the support roller spacings are determined by the edge length of the unit goods being transported (25% of the length of the transported goods).

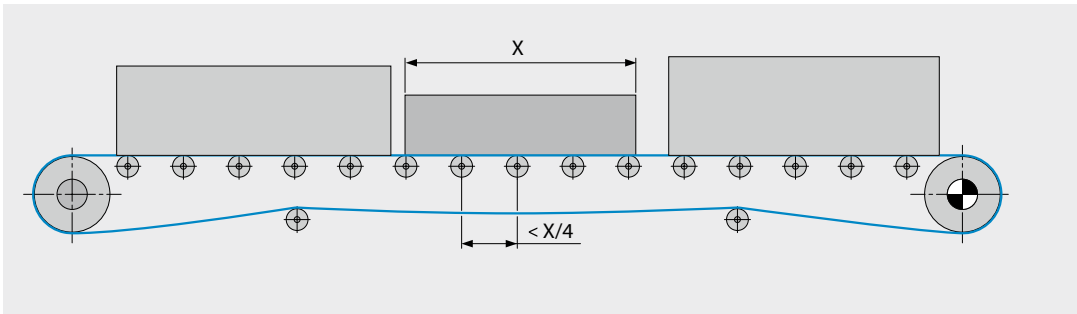

2.4 BELT SUPPORT ON THE RETURN SIDE

General

The correct design of the return side is very important for the trouble-free operation of the conveyor. It is the only way to ensure the desired (almost) tensionless operation of the belt.

When designing the belt support for the return side, also note the general information in section 1.1 and, where applicable, the notes on hygienic design in section 2.1.

- Determine the values for changes in the belt length and width at lowest/highest operating temperature, and take these into account in the design (see materials table in section 2.1).
- Include the design of the return side in all considerations concerning accessibility for maintenance and repairs, ease of cleaning the conveyor, belt changes, etc.
- Use only materials according to the specifications in the materials table in section 2.1.

2.4 BELT SUPPORT ON THE RETURN SIDE

Supporting the belt with rollers

Forbo Movement Systems recommends the use of support rollers to support the belt on the return side. Support rollers can support either the full belt width (fig.1) or sections of it (fig. 2/3).

- Preferably use support rollers that support the belt across its full width.
- Parallel to the conveyor direction, support is provided at intervals of 500 – 1800 mm (19.7 – 70.9 in).
- The roller diameter "D" must not be smaller than the permissible counter bending diameter of the belt or profiles. The respective value is to be found in section 1.1 and 1.2.
- For belts with flights and/or sidewalls, only narrow support rollers can be used. If a continuous shaft is used, a suitable large roller diameter should be chosen (Fig. 3).
- For belts in width of more than 610 mm (24 in) the flights have to be split to allow installing a belt support in the return strand.

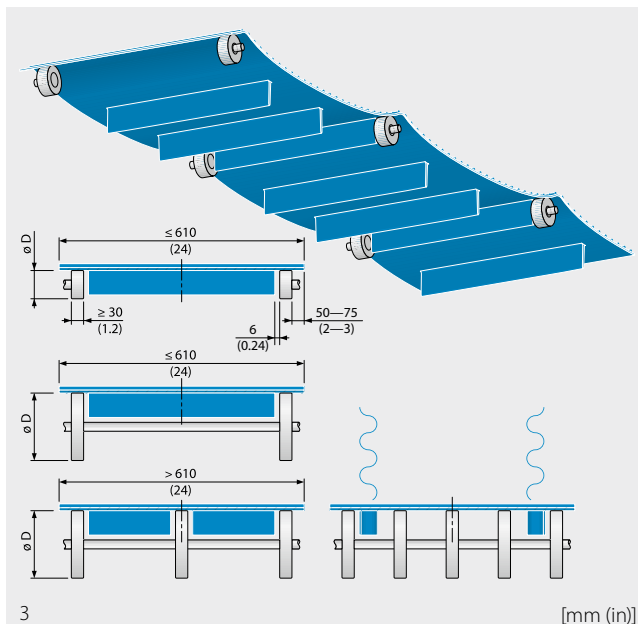
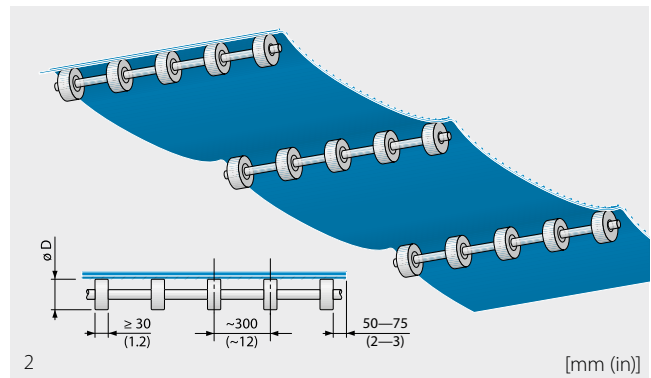
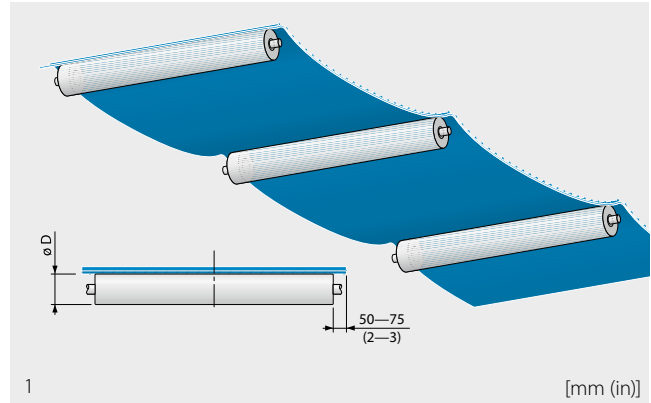

Sliding belt supports

Sliding belt supports in the return side, in the form of fixed wearstrips, slide shoes or slide shafts are often found in practice (fig. 4). Forbo Movement Systems recommends the use of support rollers to support the belt on the return side.

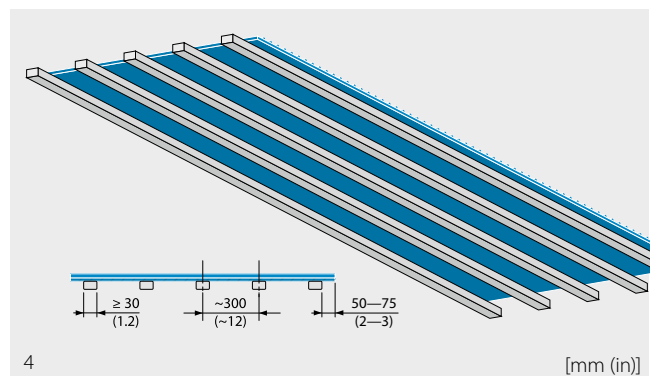

Belt sag (Positive and Center Drive only)

In sections on the return side that are not supported the belt material hangs loose (fig. 1). The height of the sag results from the belt length at the current operating temperature, the load state, and the distance between supports. The largest sag always occurs in the longest section without support.

- For the trouble-free operation of longer conveyors, plan the belt sag. Usually each of these sections is 600–1800 mm (24–70 in) long and has a sag height of between 100–400 mm (4–15.7 in).
- Specifically plan the longest unsupported section (a) as a buffer zone for belt expansion. The sagging belt loop must never rub against other parts, even in extreme cases.
- For the short sections, plan different lengths to prevent the occurrence of vibrations.
- Note that the weight of the belt in the sag affects the belt tension.
- For conveyors up to a length of 2000 mm (79 in), a belt support in the return side is not required.
- To ensure proper belt wrap position the first belt support roller/row of rollers (b) behind the drive shaft so that the belt sags as little as possible.
- Use pressure rollers (c) if necessary.

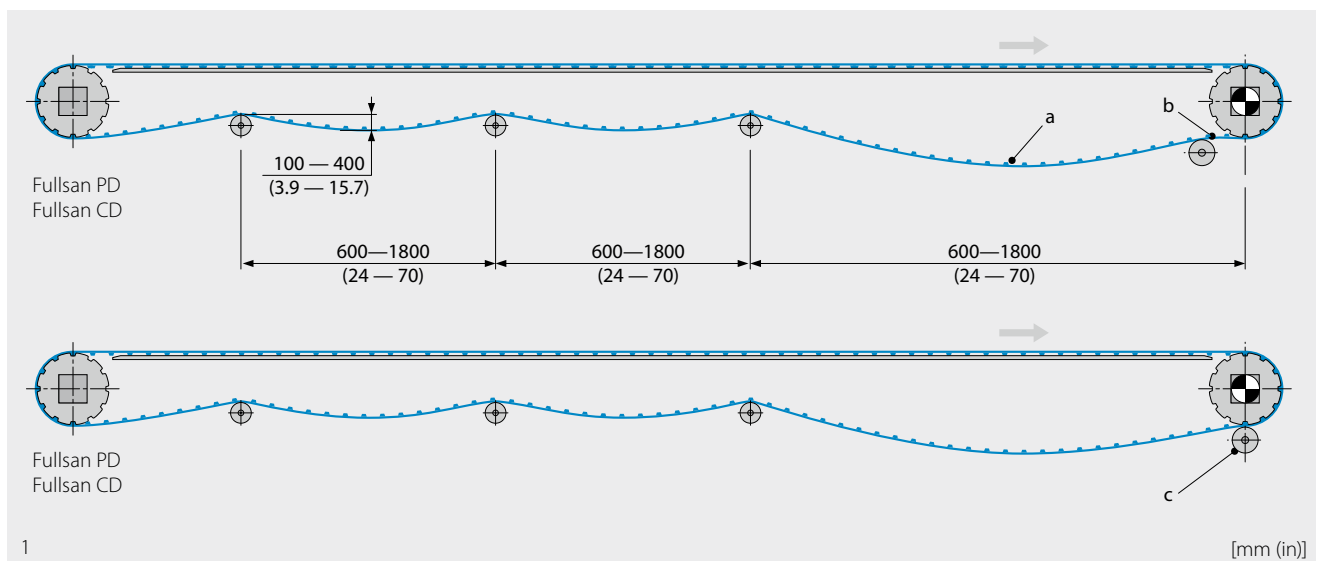

2.5 FULLSAN POSITIVE DRIVE DRIVE | PULLEYS | TRACKING

General

Fullsan Positive Drive is available as a homogenous belt or with fully enclosed tension members. It is a flat polyurethane belt with drive bars across the full belt width for form-fit power transmission. As a result, the belts are slip-free and enable accurate positioning. Sprockets can be arranged almost as close together as desired, and therefore transmit relatively high forces.

This section contains design information that applies specifically to Fullsan Positive Drive.

For important information applicable to all Fullsan series, see sections 2.1 to 2.4.

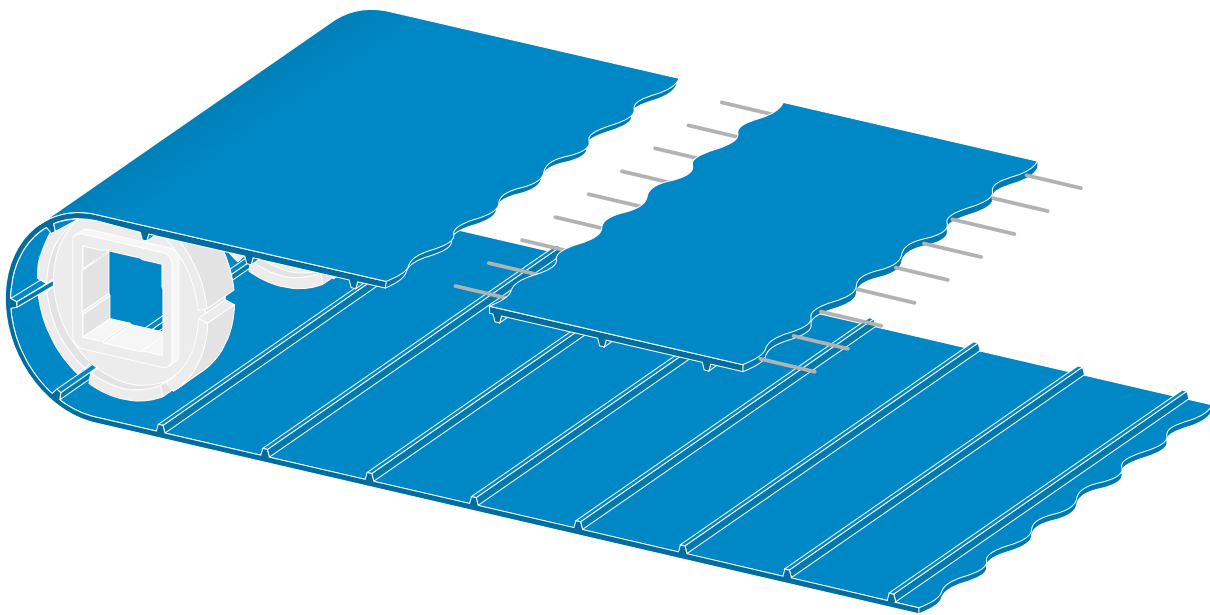

Drive types

Head drive

This drive type is used for most conveyor functions. The drive shaft is located at the head of the conveyor (outfeed side) and pulls the belt (fig. 1). For the end pulleys, either sprockets (recommended by Forbo Movement Systems) or cylindrical rollers can be used. For sprockets, pressure rollers can be provided if required (fig. 2).

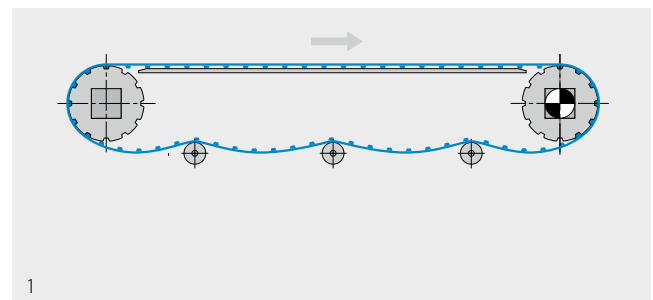

Pressure rollers

Use pressure rollers if necessary in the return side to increase the wrap angle at the drive/idler pulley and/or to minimize the distance between the carrying and return sides (fig. 2). The diameter of pressure rollers can be $1/2 d_{\min}$, if the wrap angle is not exceeding 15° .

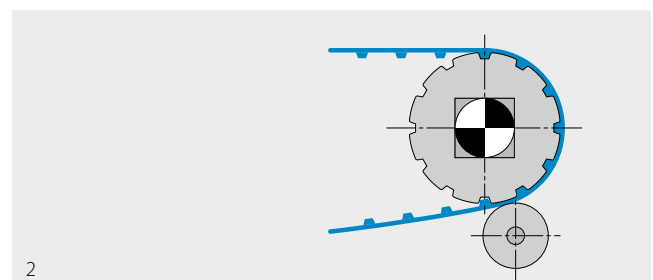

Center drive (e.g. Ω -drive)

Due to limitations in top side support on the return way caused by sidewalls and lateral profiles these are not suitable for center drive applications.

Center drive (e.g. Ω -drive) is typically used when:

- the smallest possible pulley diameters are required at the infeed and outfeed sides to minimize the transfer gap, and/or
- reversing operation is required.

Reverse operation is more complex to belt tracking and is not recommended by Forbo Movement Systems.

A large wrap angle on the drive produces optimal tooth engagement conditions for reliable power transmission in both running directions (fig. 1).

With a lighter belt load, the wrap angle can be made smaller, which also gives the conveyor a flatter shape (fig. 2).

In both cases, the axes/shafts at the ends of the conveyor system are under higher loads because the belt pull is present as belt tension on both the tight and slack sides of the belt.

- Arrange the drive shaft in the middle if possible.
- On the right and left of the drive unit, provide sections in which the belt sags. This sag is required for the necessary belt tension.
- The belt length between the snub roller and drive should be shorter than between the snub roller and the next support roller. Otherwise gravity take-ups are required in the desired sag area.
- For the end pulleys, either sprockets (recommended by Forbo Movement Systems) or cylindrical rollers can be used. For sprockets, pressure rollers can be provided if required (see “head drive”).

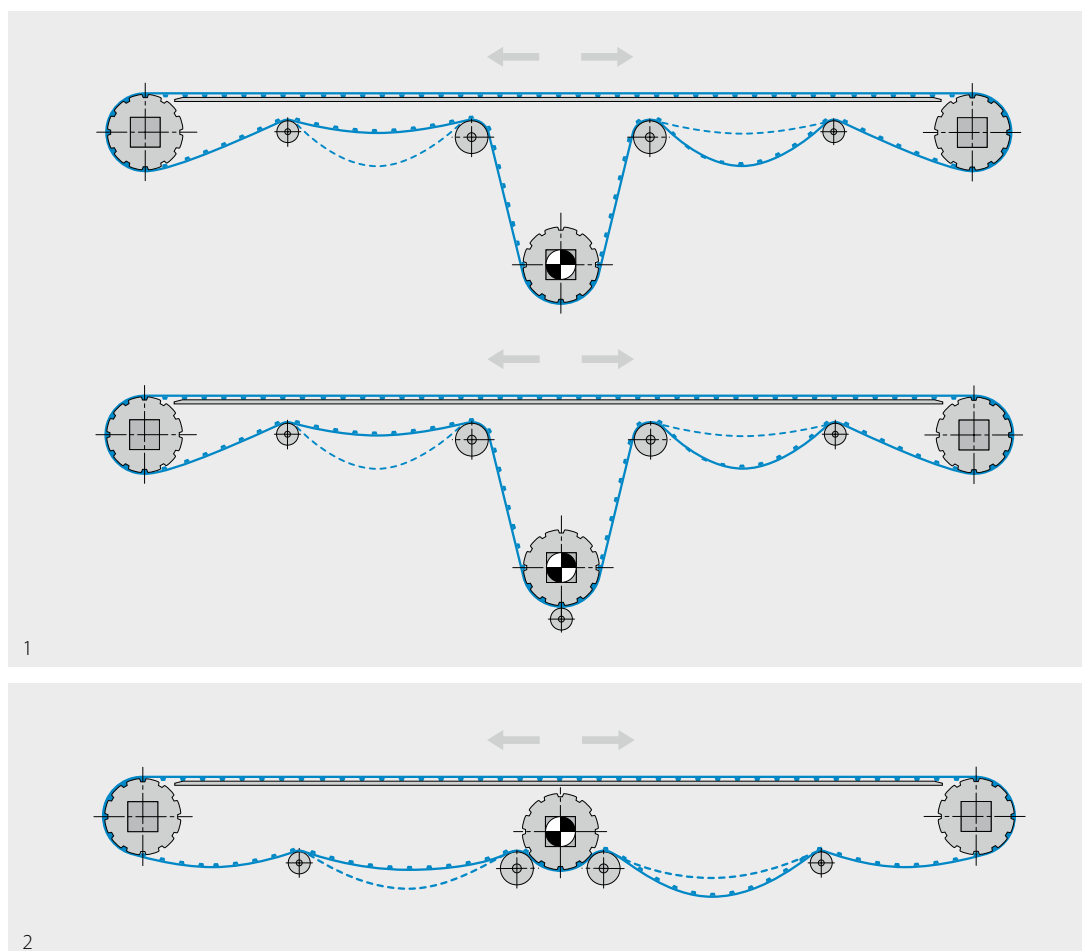

2.5 FULLSAN POSITIVE DRIVE DRIVE | PULLEYS | TRACKING

Drive and idler shaft

Shaft design

For dimensioning the shafts, see the corresponding sections in 2.2. As an alternative to a drive shaft with sprockets, a drum motor can be used.

Sprocket diameter

Sprocket diameters should always be as large as possible. The smallest permissible diameter is determined by

- the circumferential force to be transmitted according to your calculation
- the bending characteristics of the belt type used
- the bending characteristics of the welded-on lateral and longitudinal profiles (see section 1.2)
- If necessary, use pressure rollers to increase the wrap angle.

Positioning wearstrips

If parallel wearstrips are used, we recommend arranging them in line with the sprockets (fig. 1).

For heavy loads, the wearstrips can be arranged between the sprockets. This makes the gap smaller, and the belt is supported until the next sprocket (fig. 2).

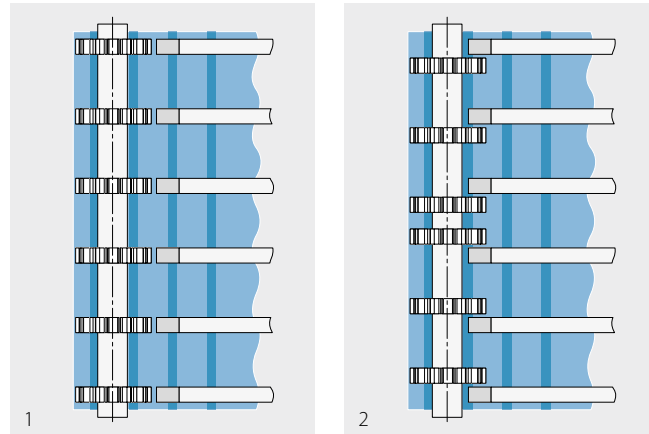

Attaching the sprockets

The sprockets should be mounted on the shaft with slight play of max. 1 mm (0.04 in) in the axial direction (figs. 3/4).

- Use one of the assembly methods shown opposite.
- Spacers can be used to fill the gaps between the sprockets.

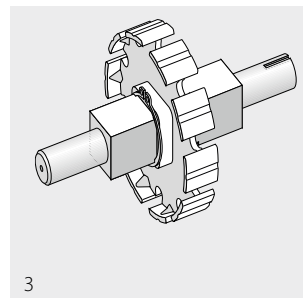

Fastened with retaining rings in accordance with DIN 471 (Seeger circlip ring)

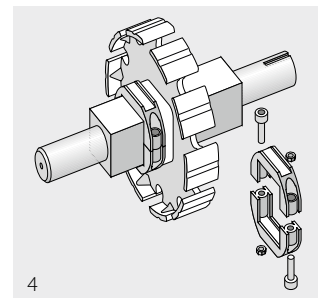

Fastened with clamp rings

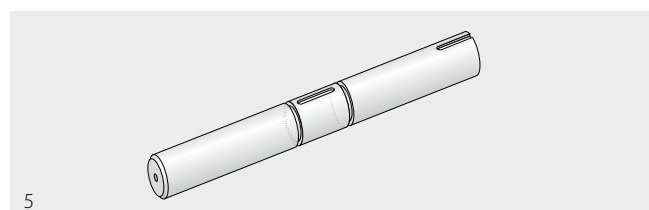

Fixation of the sprocket with retainer rings in accordance with DIN 471 (Seeger circlip ring).

Sprocket positions on the drive (fig. 1)

The distances between the sprockets should be no greater than 125 mm (4.9 in).

- Divide the belt width by 125 mm (4.9 in), round up the result and add 1. This gives you the required minimum number of sprockets. Excluded from this are narrow belts in widths of ≤ 300 mm (11.81 in). In this case rounding up is sufficient.
- If the result is an even number, we recommend adding one more sprocket.
- Never fit a belt on only one sprocket.
- Move the outer sprockets inwards by approx. 38 mm (1.5 in) and spread out the remaining sprockets evenly between them.

The number of sprockets may need to be increased depending on the load. This is calculated using the ratio between the specific and the maximum permissible belt pull.

- During operation, the belt must not dip more than 2 mm (0.08 in) between the sprockets in the drive shaft region. Add sprockets if necessary.
- For heavy loads (or if scraping needs to be particularly effective), place sprockets close together. Ensure that the design meets hygienic requirements, where necessary.

Sprocket position on the idler pulley

The idler shaft is usually fitted with sprockets in the same way as the drive shaft. If scrapers are used, it may be useful to increase the number of sprockets to achieve a better scraping result.

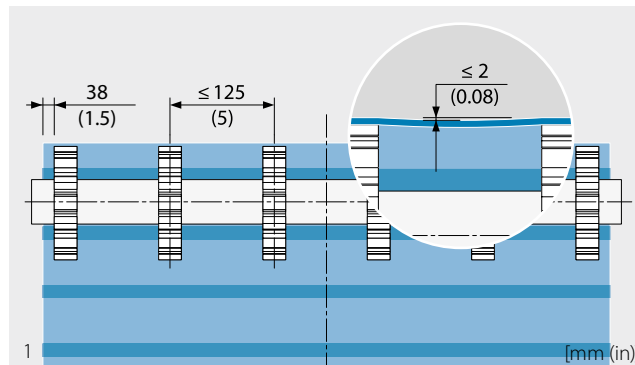

Capacity utilisation $\left[\frac{F_{adj}}{F_{adm}} \right]$	Max. distance between drive sprockets [mm (in)]
$\leq 20\%$	125 (4.9)
$\leq 40\%$	60 (2.4)
$\leq 50\%$	50 (2)
$> 50\%$	On request

F_{adj} = Adjusted belt pull
 F_{adm} = Admissible belt pull

Belt width [mm (in)]	Min. number of Sprockets
150 (5.91)	2
300 (11.81)	3
400 (15.75)	5
450 (17.72)	5
500 (19.69)	5
550 (21.65)	6
600 (23.62)	6
650 (25.59)	7
700 (27.56)	7
750 (29.53)	7
800 (31.50)	8
850 (33.46)	8
900 (35.43)	9
950 (37.40)	9
1000 (39.37)	9
1050 (41.34)	10
1100 (43.31)	10
1150 (45.28)	11
1200 (47.24)	11
1250 (49.21)	11
1300 (51.18)	12
1350 (53.15)	12
1400 (55.12)	13
1450 (57.09)	13
1500 (59.06)	13

Belt width and min. number of sprockets for PD2

2.5 FULLSAN POSITIVE DRIVE DRIVE | PULLEYS | TRACKING

Belt tracking

Conveyor design and condition

The conveyor frame should be as rigid as possible. It must not be distorted by the forces exerted by the belt. If the axes of sprocket shafts are not arranged at right angles to the belt conveyor direction, the belt will run off track (fig. 1).

All rollers, drums and shafts in the system as well as supports and guide elements should be

- clean and in a good condition,
- aligned axially parallel and at right angles to the conveyor direction,
- correctly laterally oriented in relationship to one another.

For the use of side guides, see section 2.2.

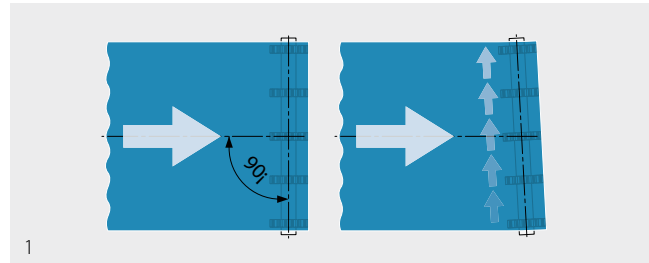

Effect of temperature

Strong asymmetrical heating and loading on a properly adjusted belt can cause uneven changes in the belt's inner tension.

Alignment at a 90° angle

- Align the conveyor torsion-free and adjust all axes and shafts so that they are horizontal (measured across the conveyor direction).
- Measure the diagonal distance "a" between the ends as shown in the drawing. If the distances are equal, the alignment is correct. Make sure that the distances in the conveyor direction are correct after alignment (fig.2).
- If the shafts are too far apart or obstacles are in the way, you can measure the distance "b" between ends and a point "A" on the center line of the conveyor (fig. 3).

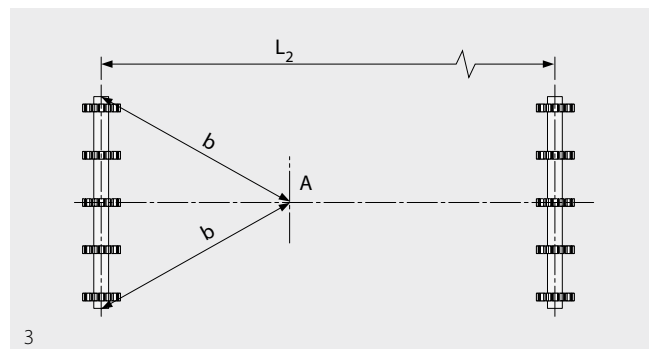
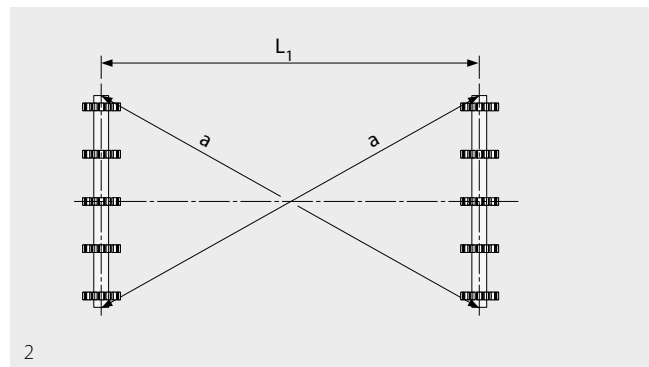

Belt tracking at the pulleys

Sprocket axes and shafts should be arranged adjustable to compensate for manufacturing tolerances in the system and belt (fig. 1).

Flanged rollers can be used for additional belt tracking.

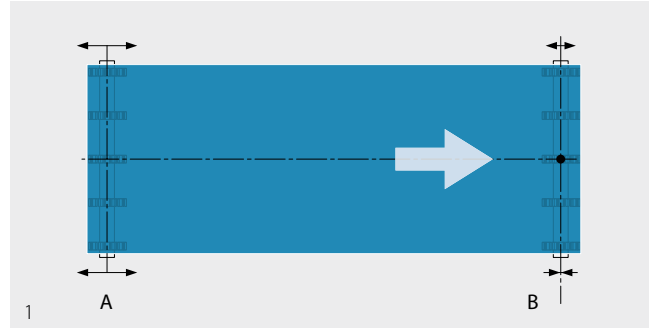

Adjustment

- Fit the belt, align pulleys A + B axially parallel, and create the desired sag in the return side.
- Correct the belt tracking by increasing or reducing the tension on one side of the drive shaft B. The belt will move towards the less tensioned side.
- It may be necessary to use a belt tracking system near the end drum (e.g. for wide, short belts).

2.6 FULLSAN CENTER DRIVE DRIVE | PULLEYS | TRACKING

General

Fullsan Center Drive is available as a homogenous belt or with fully enclosed tension members. It is a flat polyurethane belt that has one, two or three rows of lugs for form-fit power transmission (see section 1.1).

As a result, the belts are slip-free, self-tracking and enable accurate positioning.

This section contains design information that applies specifically to Fullsan Center Drive.

For important information applicable to all Fullsan series, see sections 2.1 to 2.4.

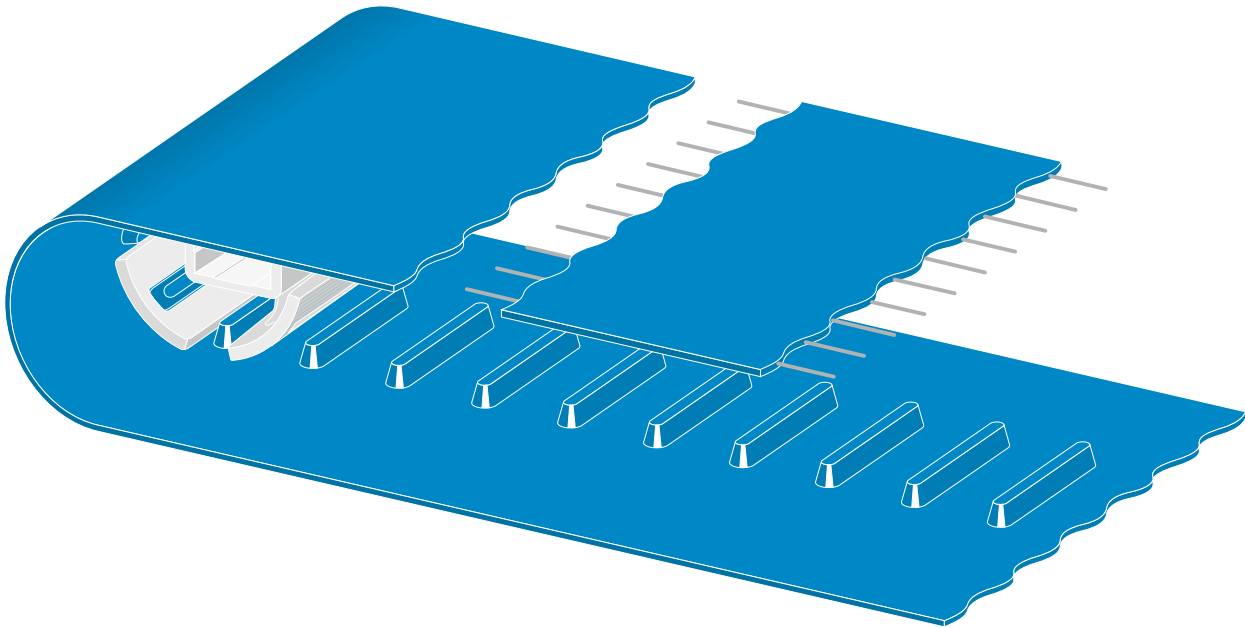

Fullsan Center Drive

Drive types

Head drive

This drive type is used for most conveyor functions. The drive shaft is located at the head of the conveyor (outfeed side) and pulls the belt (fig. 1). Pressure rollers can be provided if required (fig. 2).

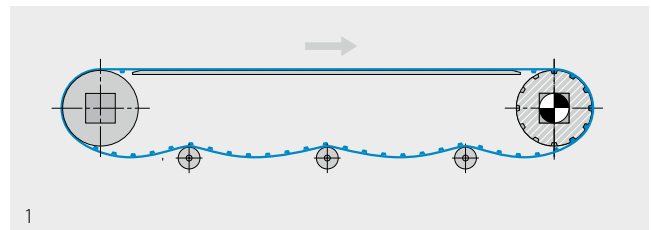

Pressure rollers

Use pressure rollers if necessary to increase the wrap angle at the drive/idler pulley and/or to minimize the distance between the carrying and return sides (fig. 2). The diameter of pressure rollers can be up to $1/2 d_{\min}$ as long as the wrap angle does not exceed 15° .

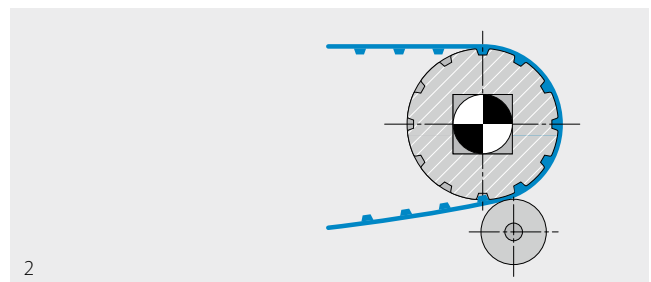

Center drive (e.g. Ω -drive)

Due to limitations in top side support on the return way caused by sidewalls and lateral profiles these are not suitable for center drive applications.

Center drive (e.g. Ω -drive) is typically used when:

- the smallest possible pulley diameters are required at the infeed and outfeed sides to minimize the transfer gap, and/or
- reversing operation is required.

A large wrap angle on the drive produces optimal tooth engagement conditions for reliable power transmission in both running directions (fig. 1).

With a lighter belt load, the wrap angle can be made smaller, which also gives the conveyor a flatter shape (fig. 2).

In both cases, the axes/shafts at the ends of the conveyor system are under higher loads because the belt pull is present as belt tension on both the tight and slack sides of the belt.

- Arrange the drive shaft in the middle if possible.
- On the right and left of the drive unit, provide sections in which the belt sags. This sag is required for the necessary belt tension.
- The belt length between the snub roller and drive should be shorter than between the snub roller and the next support roller. Otherwise gravity take-ups are required in the desired sag area.

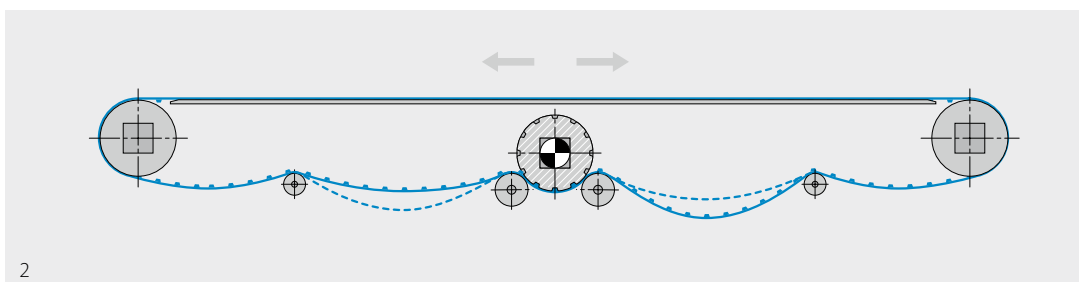
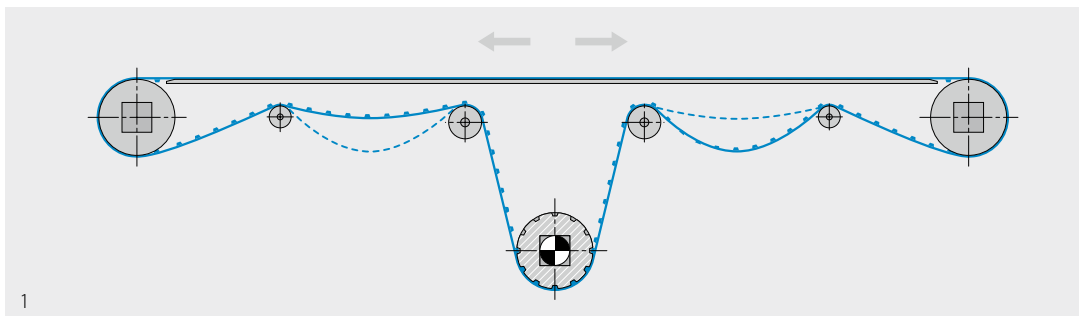

2.6 FULLSAN CENTER DRIVE DRIVE | PULLEYS | TRACKING

Drive and idler shafts

Shaft design

For dimensioning the shafts, see the corresponding paragraphs in section 2.2. As an alternative to a drive shaft with sprockets, a drum motor can be used.

Sprocket drum diameter

Sprocket drum diameters should always be as large as possible. The smallest permissible diameter is determined by

- the effective pull to be transmitted
- the bending characteristics (d_{min}) of the belt type used
- the bending characteristics (d_{min}) of the welded-on lateral and longitudinal profiles (see section 1.2).

If necessary, use pressure rollers to increase the wrap angle.

Attaching sprocket drum and idler pulleys

All sprocket drums and idler pulleys have to be fitted to the shaft with slight play in the axial direction.

- Use one of the attachment methods described in the previous section (Fullsan Positive Drive).
- Spacers can be used to fill the gaps between the sprockets.

Fullsan Center Drive recommended component reference

	Belt width [mm (in)]	Drive Sprocket	Tail Sprocket	Support rollers Width 50 mm (2 in)	Support roller Width 100 mm (4 in)	Minimum number of components per shaft	Retainer Rings per shaft
Single lug	203 (8)	1	1	0	0	1	2
	305 (12)	1	1	2	0	3	6
	457 (18)	1	1	2	0	3	6
	610 (24)	1	1	0	2	3	6
	762 (30)	1	1	4	0	5	10
Dual lug	762 (30)	2	2	0	2	4	8
	914 (36)	2	2	2	2	6	12
	1219 (48)	2	2	0	4	6	12
	1524 (60)	2	2	0	6	8	16

Sprocket drum position on the drive (fig. 1)

Fullsan Center Drive types have one, two or three rows of drive lugs on the underside of the belt.

- Provide one sprocket for each row of drive lugs.
- Position the sprockets centrally to the rows of drive lugs on your Center Drive type.
- Position the support rollers on the drive shaft as shown in the examples below.
- The molded sprockets can also be used as support rollers and reduce the rotating mass.
- A continuous support with sprockets is also possible and recommend for high belt loads.

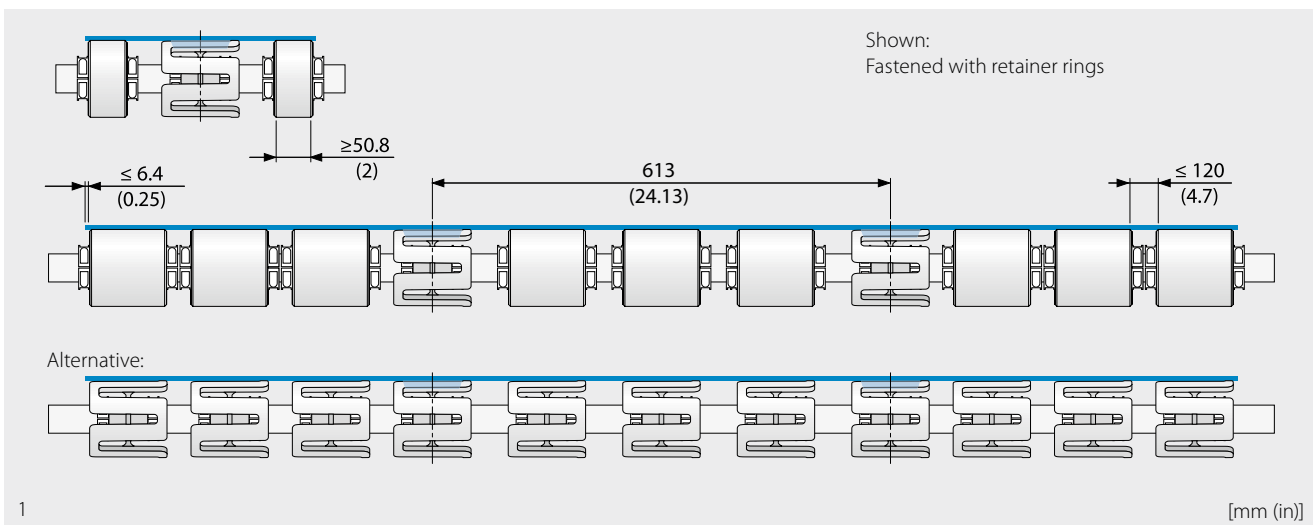

Sprocket drum positions on the idler shaft (fig. 2)

Fit components to the idler shaft to match the drive shaft; but instead of sprockets use tail rollers, which have a smaller diameter in the area of the profile rows. Molded sprockets can also be used as tail and support roller.

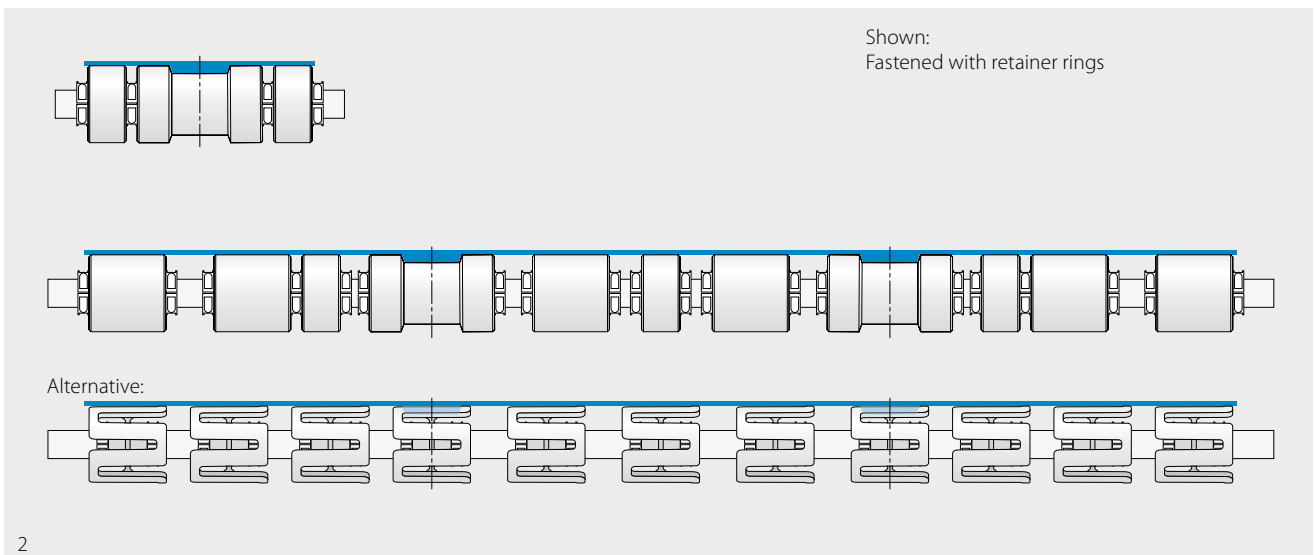

2.6 FULLSAN CENTER DRIVE DRIVE | PULLEYS | TRACKING

Belt tracking

Conveyor design and condition

The conveyor frame should be as rigid as possible. It must not be distorted by the forces exerted by the belt. If the axes of sprocket shafts are not arranged at right angles to the belt conveyor direction, the belt will run off track (fig. 1)

All rollers, drums and shafts in the system as well as supports and guide elements should be

- clean and in a good condition,
- aligned axially parallel and at right angles to the conveyor direction,
- correctly laterally oriented in relationship to one another.

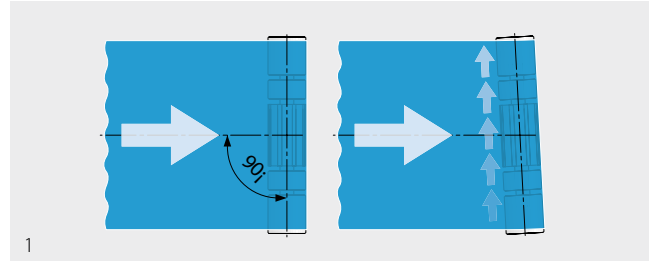

Effect of temperature

Strong asymmetrical heating and loading on a properly adjusted belt can cause uneven changes in the belt's inner tension.

Alignment at a 90° angle

- Align the conveyor torsion-free and adjust all axes and shafts so that they are horizontal (measured across the conveyor direction).
- Measure the diagonal distance "a" between the ends as shown in the drawing. If the distances are equal, the alignment is correct. Make sure that the distances in the conveyor direction are correct after alignment (fig. 1).
- If the shafts are too far apart or obstacles are in the way, you can measure the distance "b" between ends and a point "A" on the center line of the conveyor (fig. 2).

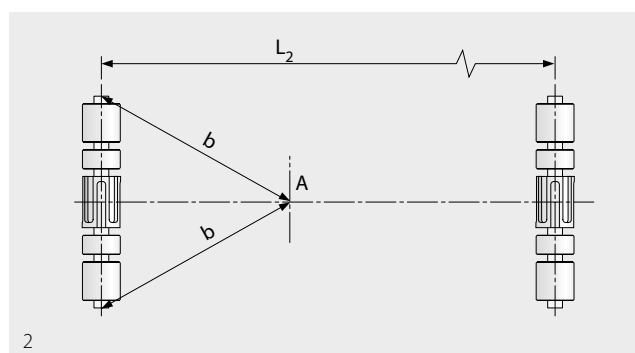
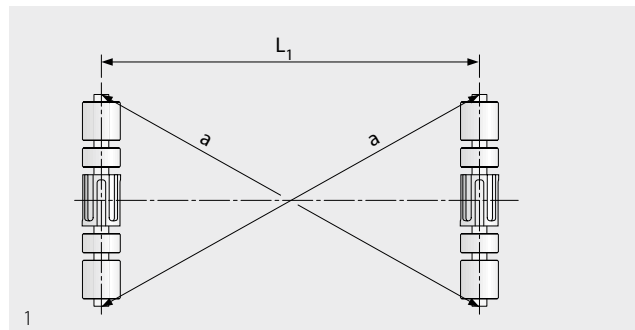

Belt tracking at the pulleys

Sprocket axes and shafts should be arranged adjustably to compensate for manufacturing tolerances in the system and belt (fig. 3).

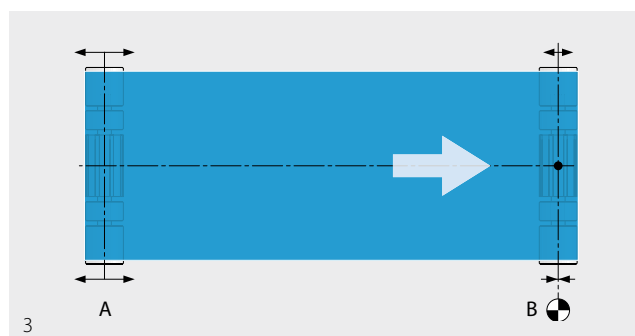

Adjustment

- Fit the belt, align pulleys A + B axially parallel, and create the desired sag in the return side.
- Correct the belt tracking by increasing or reducing the tension on one side of the drive shaft B. The belt will move towards the less tensioned side.
- It may be necessary to use a belt tracking system near the end drum (e.g. for wide, short belts).

2.7 FULLSAN FLAT

DRIVE | PULLEYS | TRACKING

General

Fullsan Flat is used as a homogenous belt or with fully enclosed tension members. As a flat polyurethane belt, it is friction-driven by a drive drum.

This section contains design information that applies specifically to Fullsan Flat.

For important information applicable to all Fullsan series, see sections 2.1 to 2.4.

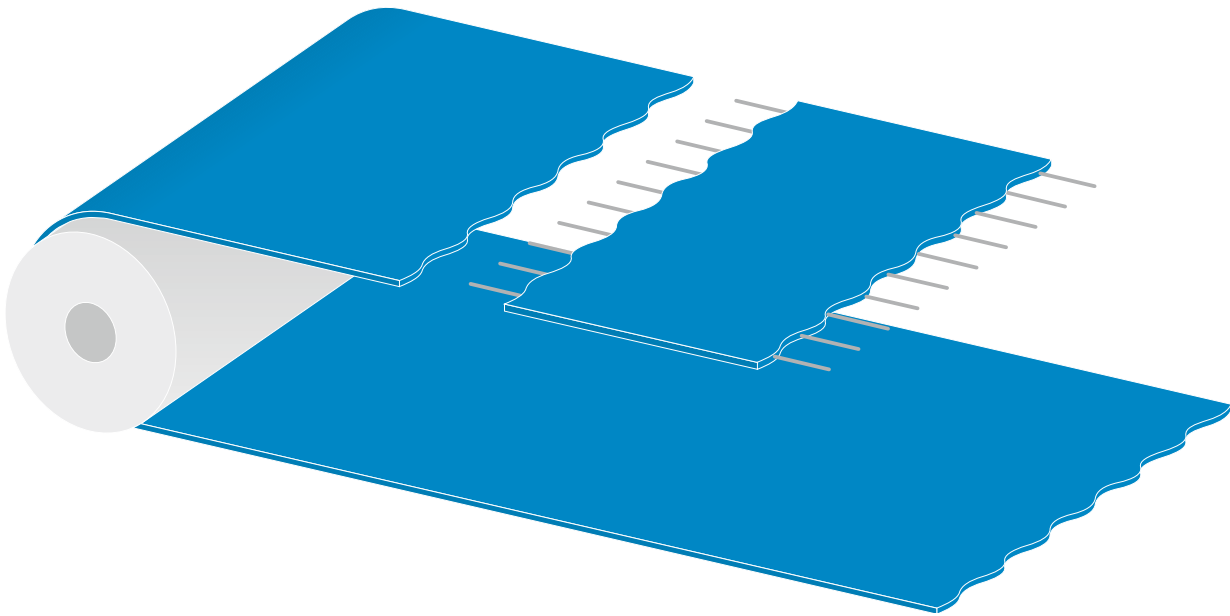

Drive types

Head drive

This drive type is used for most conveyor functions. The drive shaft is located at the head of the conveyor (outfeed side) and pulls the belt (fig. 1).

Snub rollers

Use snub rollers if necessary in the return side to increase the wrap angle at the drive/idler pulley and/or to minimize the distance between the carrying and return sides (fig. 2). The diameter of snub rollers can be up to $1/2 d_{\min}$ as long as the wrap angle does not exceed 15° .

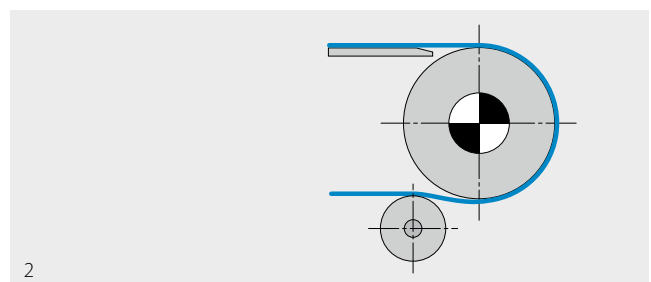
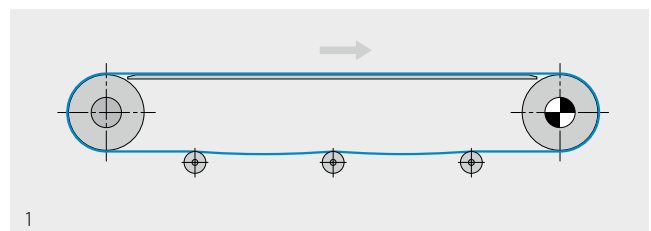

Lower head drive

This is a variant of the head drive where the drive shaft/drum is arranged in a lower position. It means that the smallest possible pulley diameter can be used at the transfer point to minimize the transfer gap (fig. 1).

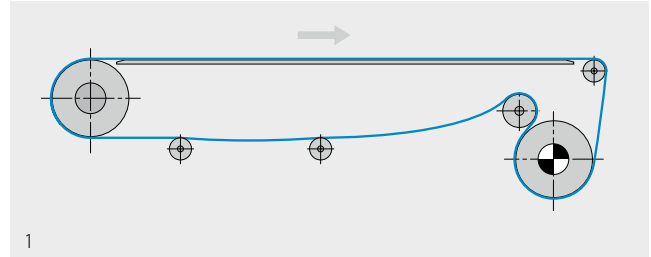

Center drive (e.g. Ω -drive)

Due to limitations in top side support on the return way caused by sidewalls and lateral profiles these are not suitable for center drive applications.

Center drive (e.g. Ω -drive) is typically used when:

- the smallest possible pulley diameters are required at the infeed and outfeed sides to minimize the transfer gap, and/or
- reversing operation is required.

Reverse operation is more complex to belt tracking and is not recommended by Forbo Movement Systems.

A large wrap angle on the drive produces optimal conditions for reliable power transmission in both running directions (fig. 2).

With a lighter belt load, the wrap angle can be made smaller, which also gives the conveyor a flatter shape (fig. 3).

In both cases, the axes/shafts at the ends of the conveyor system are under higher loads because the belt pull is present as belt tension on both the tight and slack sides of the belt.

- Arrange the drive shaft in the middle if possible.
- The belt length between the snub roller and drive should be shorter than between the snub roller and the next support roller. Otherwise weight rollers are required in the desired sag area.

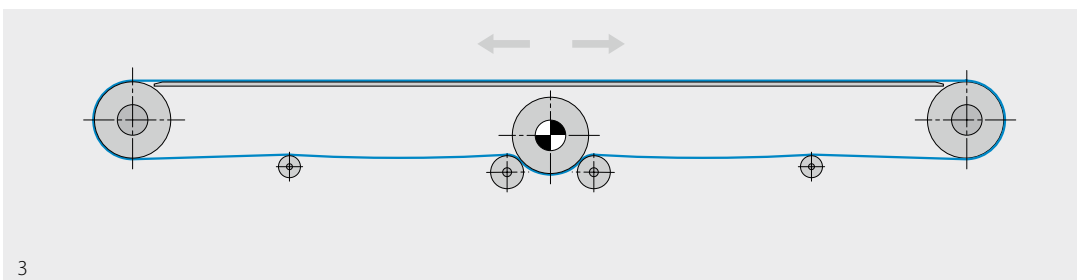
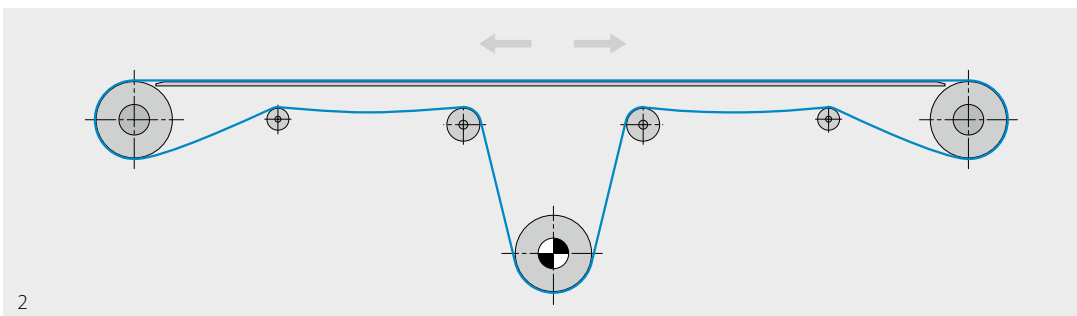

2.7 FULLSAN FLAT DRIVE | PULLEYS | TRACKING

Tail drive (pusher configuration) and alternating tail-head drive

If a head drive reverses direction, it becomes a tail drive (fig. 1).

This means that the drive unit has to push the loaded belt. In this case, if the return side tension is not greater than the carrying side tension, the belt may slip on the drive drum.

Rear drives and alternating head/tail drives may require higher pre-tension.

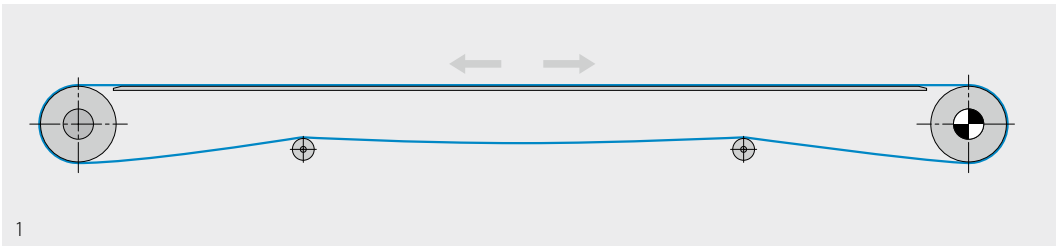

Drive and idler drums

Shaft design

For dimensioning the shafts, see the corresponding paragraphs in section 2.2. As an alternative to a conventionally drive shaft, a drum motor can be used.

Geometry of drive and idler drums

If the diameter is too small, it will lead to unacceptable deflection of the drums, particularly on wide systems. This will cause undesired wrinkling of the belt and poor tracking.

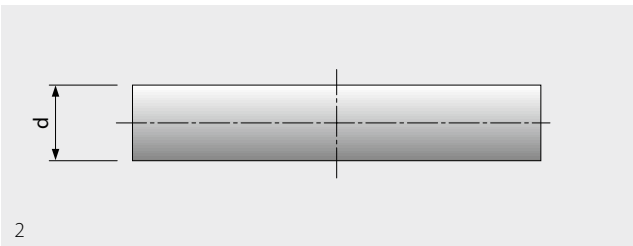

Please do a check calculation. Drum diameters should always be as large as possible.

The smallest permissible diameter is determined by

- the circumferential force to be transferred
- the bending characteristics of the belt type used
- the bending characteristics of the welded-on lateral flights and longitudinal profiles see section 1.2.

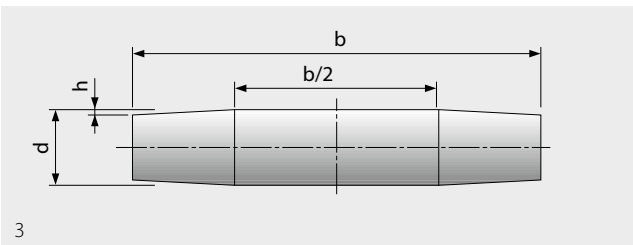

Drive and idler drums can be cylindrical (fig. 2) or conical-cylindrical (fig. 3).

Conical-cylindrical drums are particularly useful for short belts due to their higher tracking effect. Should the belt width be significantly smaller than the drum length, the belt width is decisive for the division of the drive drum.

Drum dia. [mm (in)]	< 200 (7.87)	200 (7.87) – 500 (19.68)	> 500 (19.68)
Conicity "h" [mm (in)]	0.5 (0.02)	0.8 (0.03)	1.0 (0.04)

Manufacturing note

The running surfaces of all drums should be smoothly finished.

Excessive grooves will produce an undesired guiding effect.

Roughness $R_z \leq 25$ (DIN EN ISO 4287), (roughness depth $\leq 25 \mu\text{m}$)

Use only drums whose surface was machined in two turning processes from the middle outwards (or from the edges to the middle). Half of the resulting turning grooves will then have a right-hand "thread" and half a left-hand "thread"; their steering effects will cancel each other out.

2.7 FULLSAN FLAT DRIVE | PULLEYS | TRACKING

Belt tracking

Conveyor design and condition

The conveyor frame should be as rigid as possible. It must not be distorted by the forces exerted by the belt. If the axes are not arranged at right angles to the belt conveyor direction, the belt will run off track (fig. 1).

All rollers, drums and shafts in the system as well as supports and guide elements should be:

- clean and in a good condition,
- aligned axially parallel and at right angles to the conveyor direction,
- aligned laterally in relationship to one another.

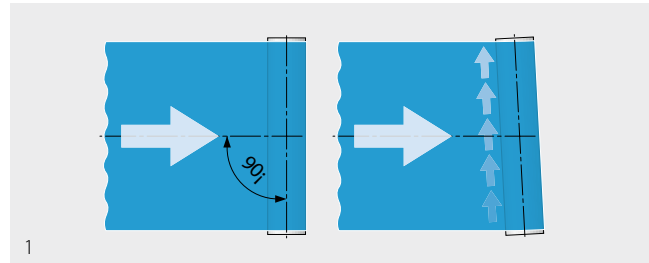

Effect of temperature

Strong asymmetrical heating and loading on a properly adjusted belt can cause uneven changes in the belt's inner tension.

This creates steering forces which could cause the belt to run off track. In these cases, an automatic belt tracking system is recommended.

Alignment at a 90° angle

- Align the conveyor torsion-free and adjust all axes and shafts so that they are horizontal (measured across the conveyor direction).
- Measure the diagonal distance "a" between the ends as shown in the drawing. If the distances are equal, the alignment is correct. Make sure that the distances in the conveyor direction are correct after alignment (fig. 2).
- If the shafts are too far apart or obstacles are in the way, you can measure the distance "b" between ends and a point "A" on the center line of the conveyor (fig. 3).

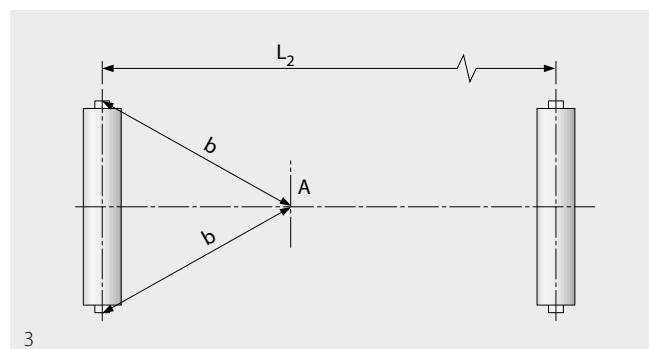
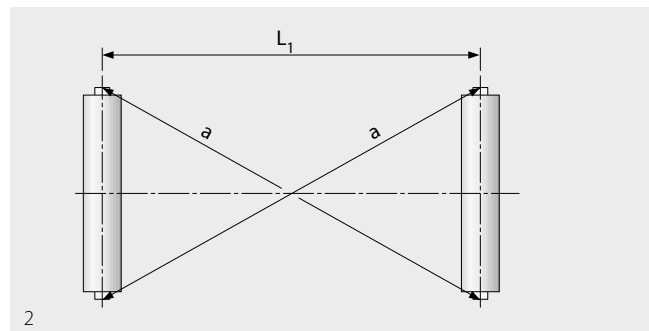

Belt tracking at the pulleys

Drums, rollers and shafts should be arranged adjustably to compensate for manufacturing tolerances in the system and belt (fig. 1). If satisfactory belt tracking cannot be achieved in this way, options include using slanting rollers or automatic belt tracking systems.

For so-called “undersquare” systems (axis distance ~ belt width) or an even worse length/width ratio, the belt can no longer be adjusted via conical-cylindrical or crowned drums.

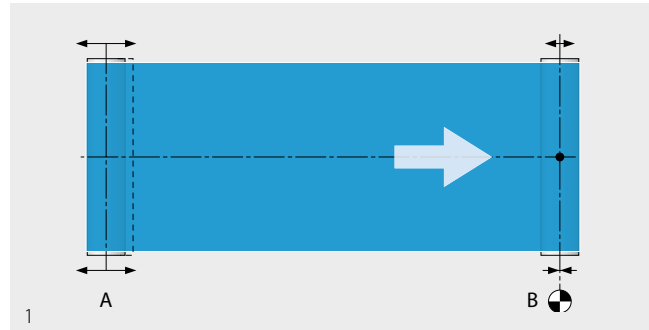

Adjustment

- Fit the belt, align pulleys A + B axially parallel, and adjust the tensioning drum parallel to the axis until the required operating tension is reached.
- Correct the belt tracking by increasing or reducing the tension on one side of the drive shaft B. The belt will move towards the less tensioned side.
- It may be necessary to use a belt tracking system near the end drum (e.g. for wide, short belts).

Belt tracking with snub rollers

A very effective way to track the belt is to use snub rollers C, D (fig. 2).

The greatest tracking effect is always exerted by the snub roller where the return side meets the end pulley.
 if the belt runs in direction 1, snub roller C.
 if the belt runs in direction 2, snub roller D.

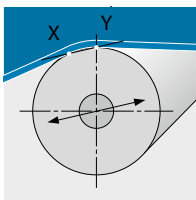
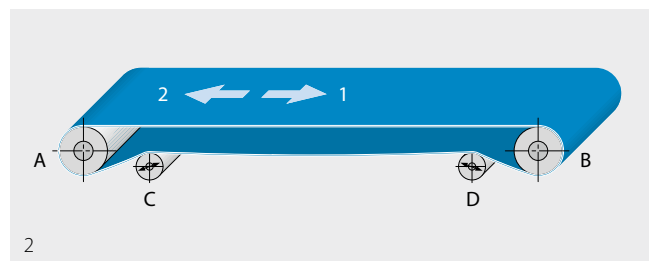

The snub rollers should be adjustable only in direction X Y (belt run-on and run-off point). That way, the belt edges are hardly affected at all. Highly effective automatic belt tracking control can be implemented with the aid of motorized adjustable snub rollers.

Adjustment

- Set axes and shafts axially parallel as a basic setting.
- Install the belt and adjust the tensioning drum parallel to the axis until the required operating tension is reached.
- Correct the belt tracking via drum C or D. A belt tracking system using drum C or D as the control drum may be required.

2.7 FULLSAN FLAT DRIVE | PULLEYS | TRACKING

Belt tracking with center drive/ Ω -drive

Snub pulleys G and F as well as the drive shaft E are adjustable in the direction of the arrow (fig. 1).

As a simple design solution, the mounts for G, F and E can be installed on a plate H which is moveable along the returnway.

For the arrangement, design and control characteristics of drums A, B, C and D, see the previous and next pages.

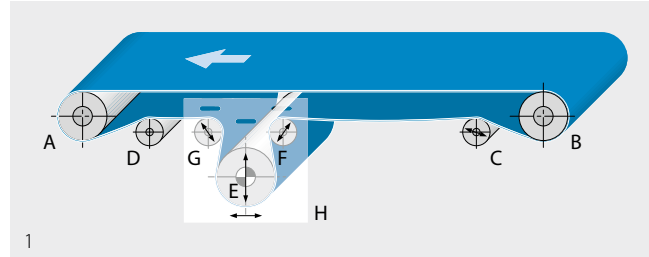

Adjustment

- Set axes and shafts axially parallel as a basic setting.
- Install the belt and adjust the tensioning drum parallel to the axis until the required operating tension is reached.
- Correct belt tracking via the snub roller C and if necessary via the bend pulleys G and F or plate H. A belt tracking system may be required here too.

Belt tracking with reversing systems

The precision with which the system and belt are manufactured is important for trouble-free belt tracking in reversing operation.

It is not easy to adjust the belts correctly in reversing operation. Once the conveyor belt is adjusted correctly in one conveyor direction, it often runs off track in the other conveyor direction. It takes some time to adjust the drums correctly (fig. 2).

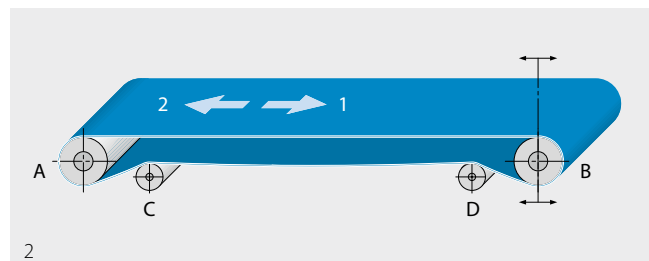

Adjustment

- Set axes and shafts axially parallel as a basic setting.
- Install the belt and adjust the tensioning drum parallel to the axis until the required operating tension is reached.
- In reversing operation, the belt tracking should be adjusted not at the snub rollers but at the end pulleys.

Effect of support rollers

For troughed belts, tracking can be improved by rotating the side rollers at some roller stations forwards by up to approx. 3° in the direction of belt travel, depending on the belt speed (fig. 1).

You can often control non-troughed belts adequately by installing some horizontally adjustable support rollers, then pivot them forwards by about $2-4^\circ$ (fig. 2).

The effect of supporting rollers can mainly be used with long belts.

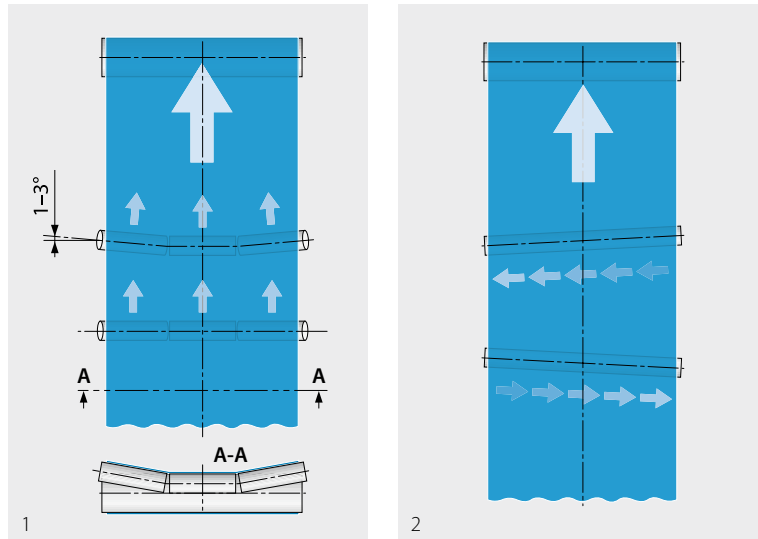

Effect of negatively troughed roller sets

A negatively troughed roller set in the return side is very effective at centring the belt, if it is positioned close to the tail drum (fig. 3).

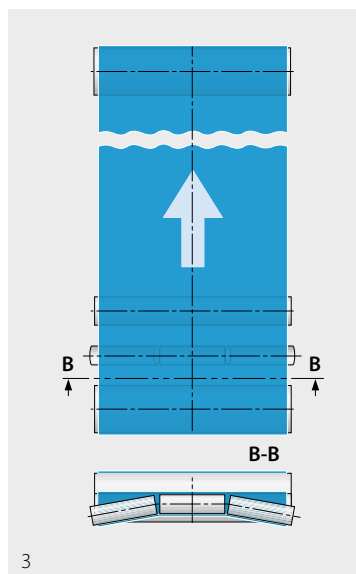

Belt edge sensors

Different types of belt edge sensors are available, e.g. mechanical, hydraulic, electrical, optical and pneumatic. They activate the the belt tracking system when the belt edge position changes.

Automatic belt tracking

Automatic belt tracking systems are often used with tilting snub rollers. They are usually adjusted by means of electrically operated threaded spindles or pneumatic cylinders according to the current belt edge values detected by the belt edge sensors.

Purely mechanical solutions without auxiliary energy are also possible on small systems.

2.7 FULLSAN FLAT DRIVE | PULLEYS | TRACKING

Absorbing lateral forces with longitudinal profiles

Lateral forces arising e.g. due to transported material entering or exiting from the side can be absorbed by welded-on longitudinal profiles in the conveyor path support area.

- For systems with a length/width ratio of less than 2, the belt can be guided by grooves in drums/taper rollers. If the ratio is greater than 2, it should be guided by grooves in the table or between wearstrips so that the profile does not climb up the edge of the groove and destroy the belt (fig. 1/2).
- The grooves for longitudinal profiles should be at least 8–10 mm (0.31–0.36 in) wider and 2 mm (0.08 in) deeper than the profile. The large amount of play enables adjustment of the belt without it immediately rubbing at the sides.
- If heavy soiling is anticipated, increase the groove depth.
- For minimum belt lengths and details of profile dimensions, types and minimum drum diameters, see “Technical information 2”, ref. no. 318.
- For large lateral forces, provide an automatic tracking device.

Do not fix guide strips until the belt is running properly. A minimum play as specified in section 2.2 must remain to allow for tolerances.

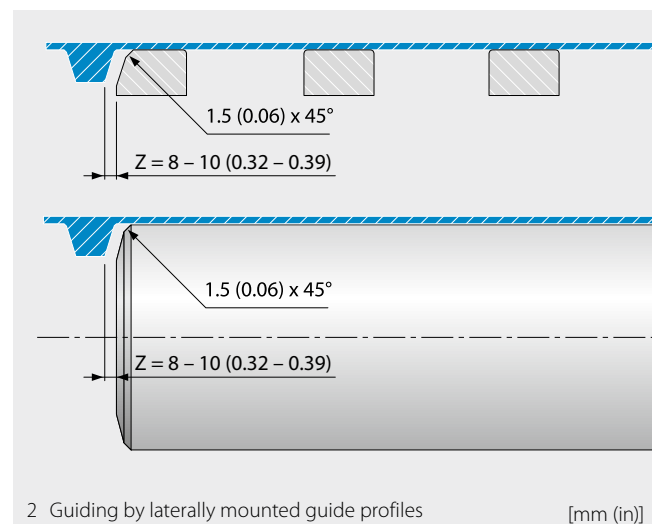
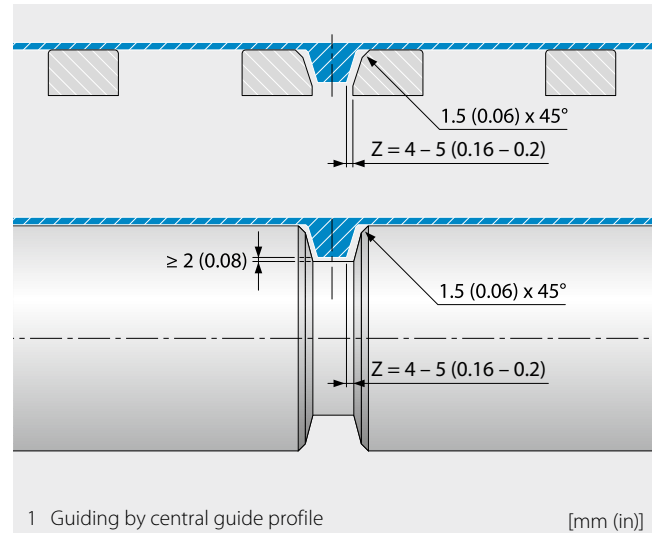

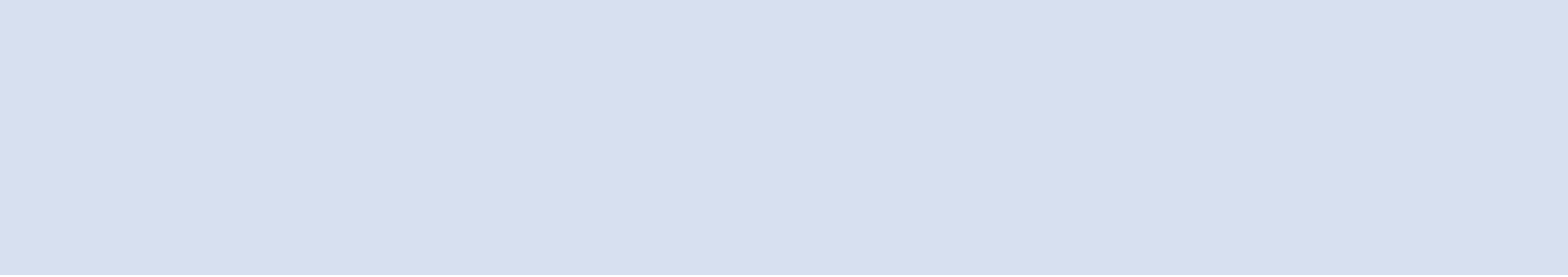



3 CONVEYOR LAYOUTS

- 3.1 Horizontal conveyors
- 3.2 Incline/decline conveyors
- 3.3 Hockey-stick and swan-neck conveyors
- 3.4 Troughed conveyors

3.1 HORIZONTAL CONVEYORS

General

In conveyors that are aligned horizontally, the conveyor belt runs around two end pulleys, one of which is a drive pulley. The idler can be used as a take-up.

Preferably the drive is located at the outfeed side of the conveyor. In this case it is called head-end. With this arrangement, the transmission forces are applied more efficiently than with a tail drive.

Conveyor layouts

Up to length of 2000 mm (78.7 in), horizontal conveyors can be designed without belt supports in the return side (fig. 1). With axis intervals > 2000 mm (78.7 in), belt supports (preferably return rollers) should be fitted in the return side (fig. 2). This prevents excessive sagging due to the belt's own weight.

- Use the belt sag to compensate for belt length changes due to temperature and load fluctuations. Specifically plan the longest unsupported section as a buffer zone for belt expansion.

See section 2 "Conveyor design" for all design details.

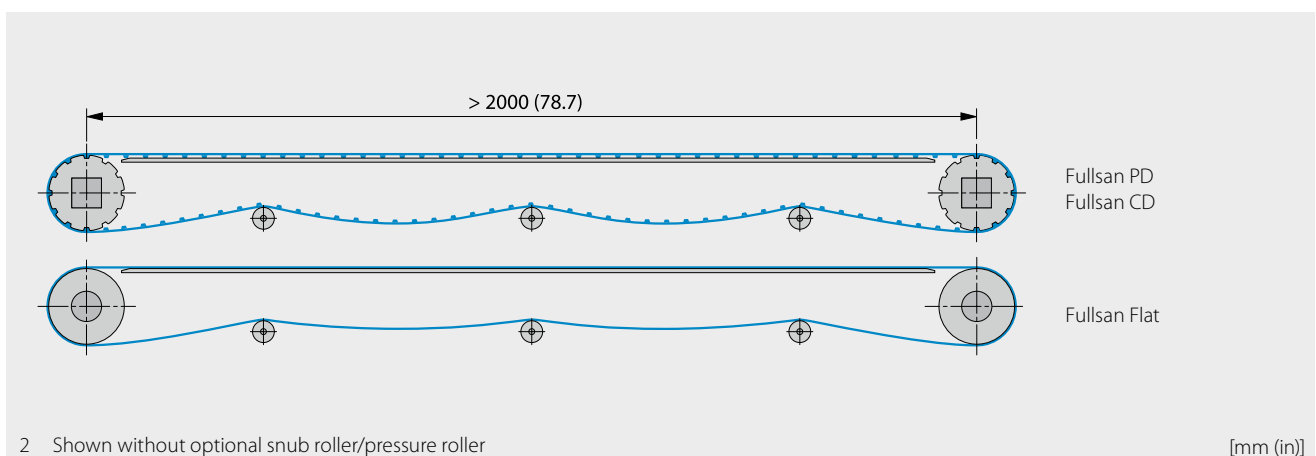
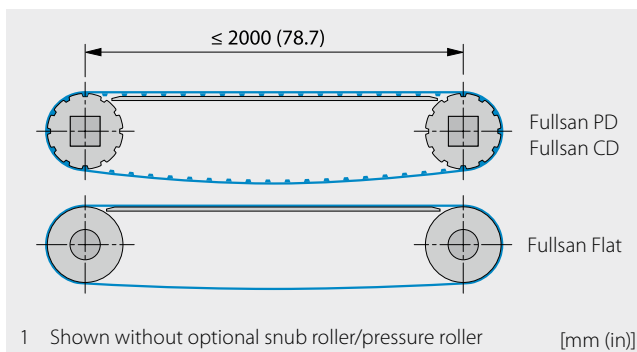

3.2 INCLINE/DECLINE CONVEYORS

General

In straight incline/decline conveyors (without a change of angle), the conveyor belt runs around two end pulleys, one of which is a drive pulley. The idler can be used as a take-up.

The design of the drive depends on the conveyor direction (incline or decline). Conduct your own experiments to determine the conveyor angle that can be realized for your conveying task, and consider the use of sidewalls and/or flights, if necessary.

Incline conveyor (fig. 1)

Generally we recommend the following:

- Use only a head drive (i.e. use the upper shaft as the drive shaft).
- Ensure there is always a screw tension take-up system or force-dependent take-up on the tail, since the belt tension (generated by the belt sag) decreases with an increasing conveyor angle.
- If the belt width is wider than 600 mm, we recommend providing additional supports on the belt surface or between the flights in the return side.

See section 2 "Conveyor design" for all design details.

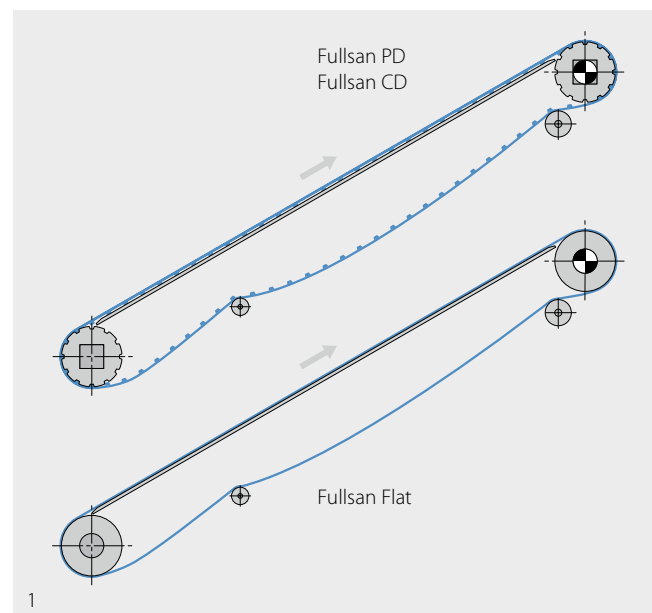

Decline conveyor (fig. 2)

Generally we recommend the following:

- Drive type head drive
- Ensure there is always a screw tension take-up system or force-dependent take-up on the tail, since the belt tension (generated by the belt sag) decreases with rising gradient.
- If the belt width is wider than 600 mm, we recommend providing additional supports on the belt surface or between the flights in the return side.
- In case of heavy load a tail drive configuration can be recommended.

See section 2 "Conveyor design" for all design details.

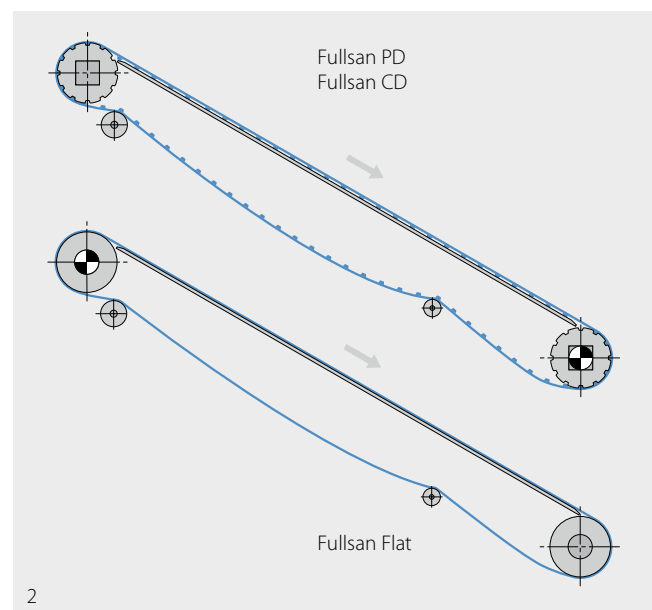

3.3 HOCKEY-STICK AND SWAN-NECK CONVEYORS

General

A **hockey-stick conveyor** (L-conveyor) has a horizontal conveyor section in the lower part of the conveyor, and a conveyor section with a gradient angle (fig. 1). The conveyor direction is usually upwards. A head drive is usual. If there is limited space around the head drum, a tail drive can work but is generally not recommended. The belt undergoes at least one counter bend due to contact with guide elements on the carrying side.

A **swan-neck conveyor** (Z-conveyor) has a horizontal conveyor section at the bottom of the conveyor, a conveyor section with a gradient angle, and a horizontal section at the top of the conveyor (fig. 2). The conveyor direction is usually upwards. If there is limited space around the head drum, a tail drive can be used. In this case, the tensile forces in the belt can only be small, since the concave bending in the return side is critical.

The belt undergoes at least two counter bends due to contact with guide elements on the carrying side. With this arrangement, the transmission forces are applied more efficiently than with a tail drive.

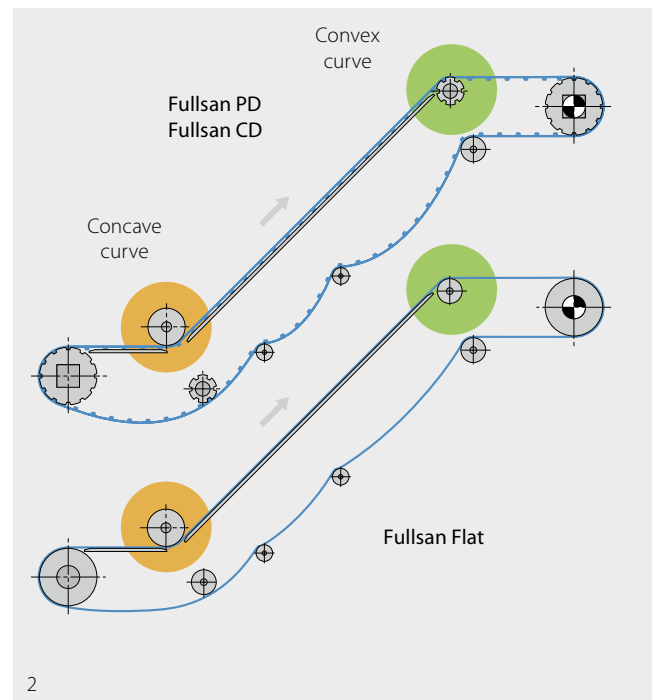
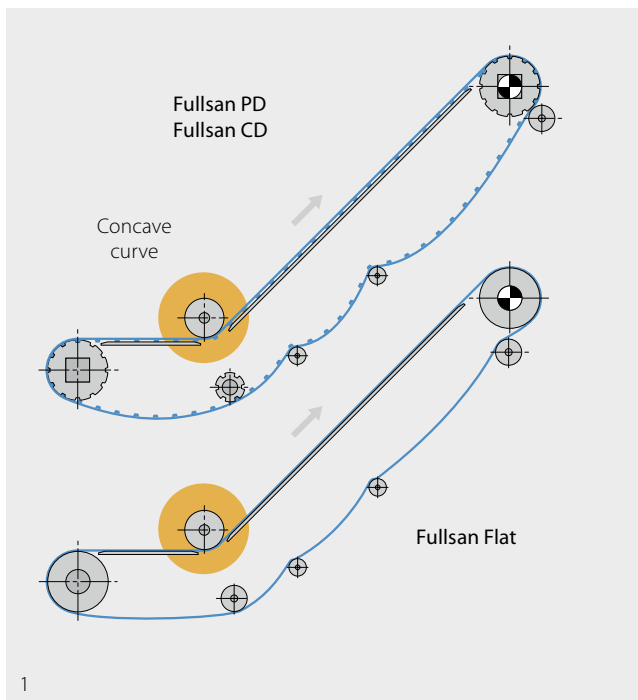

Use of profiles (flights, sidewalls) and bending/counter-bending radii

For incline conveying, it is often useful to equip conveyor belts with profiles (flights, sidewalls) (fig. 1).

- **Lateral flights** (1) ensure that the transported material is carried on the belt
- **Sidewalls** (2) enclose the belt's conveying area at the sides
- **Longitudinal profiles positioned centrally on the running side** (3) ensure central tracking of the belt (Fullsan Flat)
- **Longitudinal profiles at the edges of the belt on the running side** (4) or on the carrying side (5) are required for guidance and to ensure a constant width if the transverse rigidity of the belt including any welded-on sidewalls is not sufficient to keep the belt laterally stable in the concave curve.

In these cases, the minimum bending/counter-bending radii are dependent not only on the belt type but also on the profiles (flights, sidewalls) that are used.

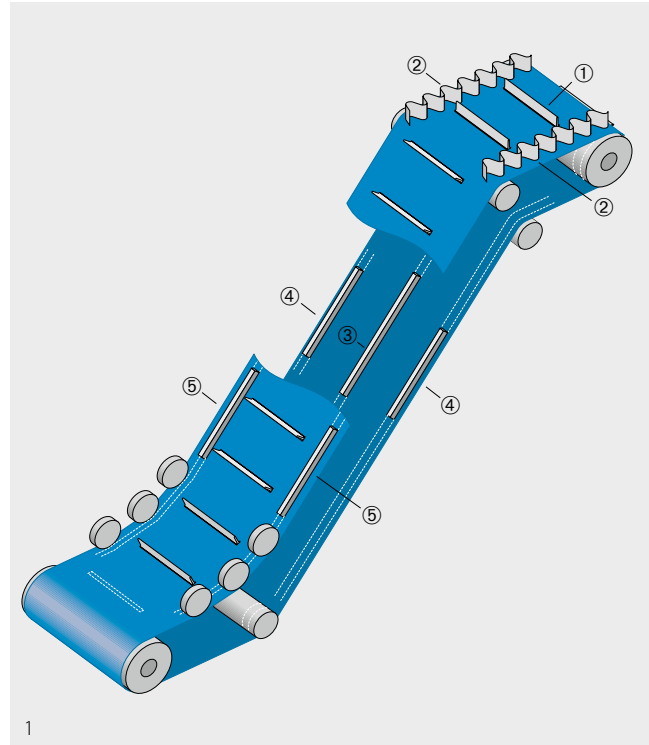

Drive

Hockey-stick and swan-neck conveyors almost exclusively use head drives. The upper drum is used as the drive drum, and is provided with a friction coating (Fullsan Flat) or sprockets. The motor should be designed for low accelerations, as otherwise many system components can be placed under excessive loads.

- Ensure there is always a screw tension take-up system or force-dependent take-up on the tail, since the belt tension (generated by the belt sag) decreases with an increasing conveyor angle.

3.3 HOCKEY-STICK AND SWAN-NECK CONVEYORS

Belt guidance in the concave curve (top side of belt)

Forbo Movement Systems recommends roller support on any counter-bending/transition section of the conveyor.

- Use hold down rollers (fig. 1) having the permissible d_{min} to hold down the belt edge (minimum width "B" in each case 30 mm (1.2 in);
 - > cylindrical rollers (1) for belts without longitudinal profiles on the carrying side,
 - > V-pulleys or guide rollers (2/3) for belts with longitudinal profiles on the carrying side (guide profiles).
- Forbo Movement Systems does not recommend the use of skids or wearstrips.
- When using sidewalls and/or lateral profiles, the smallest permissible deflection diameter increases if the d_{min} of the sidewall/profile is larger than the d_{min} of the belt on its own (see section 1.2).
- When using V-shaped profiles, the smallest permissible deflection diameter increases if the d_{min} of the profile is larger than the d_{min} of the belt on its own (for values see section 1.2).
- Between the belt supports and profiles/sidewalls, allow a gap at the side of at least 6 mm (0.25 in) (fig. 2).
- For belt widths exceeding 600 mm (23.6 in), additional support rollers are recommended on the return side. In these cases, gapped flights are required.

For low and unchanging gradient angles, it is sufficient to use one pressure roller (4) on each side of the belt (with a counter bending radius of $r > 200$ mm (7.87 in) (fig. 3).

For larger and changing gradient angles, multiple pressure rollers (5) can be used at each side of the belt (at least three). Their diameter can be smaller than when using a single roller per side. An overall deflection radius of > 200 mm (7.87 in) must be maintained, however, since the arcs of contact at the local deflection points could cause breaks in the spliced area of the belt (fig. 3).

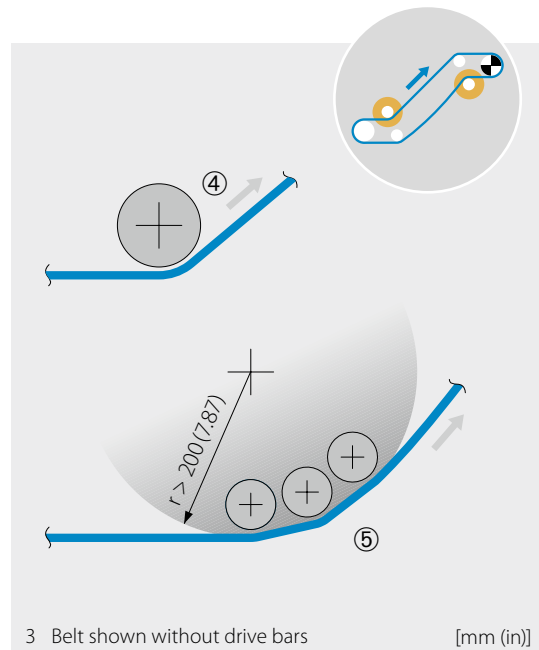
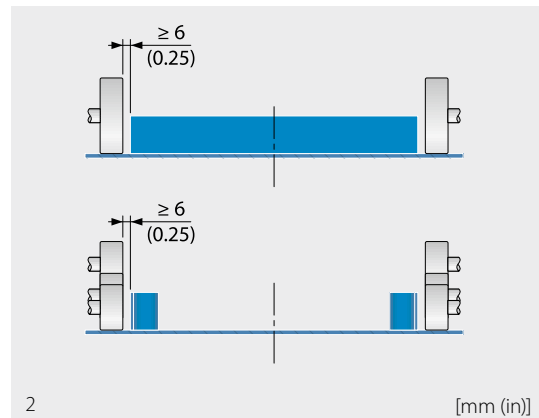
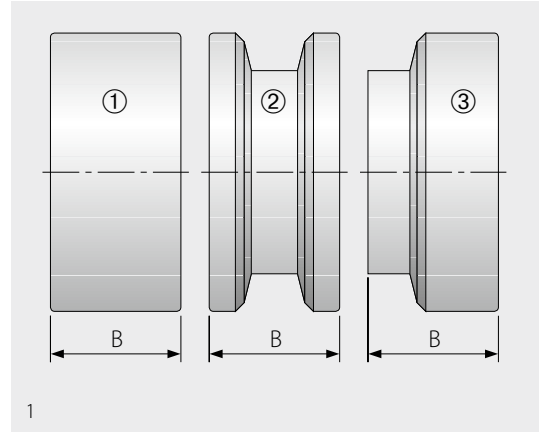

Belt guidance in the convex curve (underside of belt)

Especially if the belt is operated dry without lubrication, high friction resistance occurs at this bending point.

- Preferably (depending on the belt type) use rollers or sprockets as an end pulley that meet the permissible d_{\min} across the full width of the belt (fig. 1).
- Forbo Movement Systems does not recommend the use of skids or wearstrips (fig. 2).

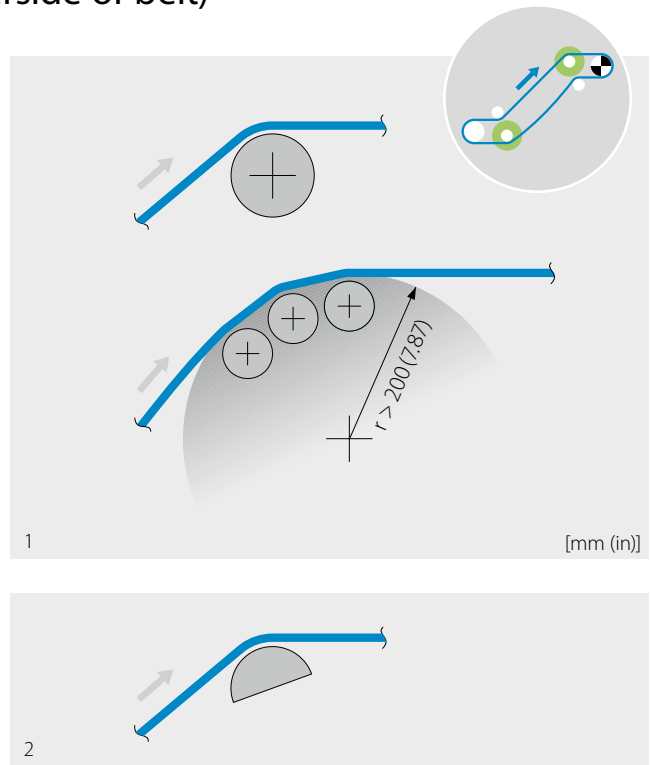

3.4 TROUGHED CONVEYORS

General

For transporting bulk solids, conveyors with troughed belts are frequently used. These can operate horizontally or at a gradient. Design the trough cross-section according to the belt type used and the conveyor width/task. The idler can be used as take-up.

Preferably the drive is located at the outfeed side of the conveyor, in this case called the head-end. With this arrangement, the transmission forces are applied more efficiently than with a tail drive.

Transitional area between end pulley and trough

Where the troughed belt transitions from the drum onto the supporting rollers (and vice versa), the edges are subjected to increased elongation (fig. 1).

Therefore please observe the guide values listed in the table for the transition length l_s .

$$l_s = \text{belt width } b_0 \cdot \text{factor } c_7 \quad [\text{mm}]$$

Trough angle	15°	20°	30°	40°
c_7	0.7	0.9	1.5	2

Trough angle

Possible trough angles depend on the belt width:

- Belt width < 300 mm (11.8 in) trough conveying not recommended
- Belt width 300–500 mm (11.8–19.7 in) trough angle up to 30°
- Belt width > 500 mm (19.7 in) trough angle up to 45°

Depending on the Fullsan type used, different trough shapes can be realized (see following pages).

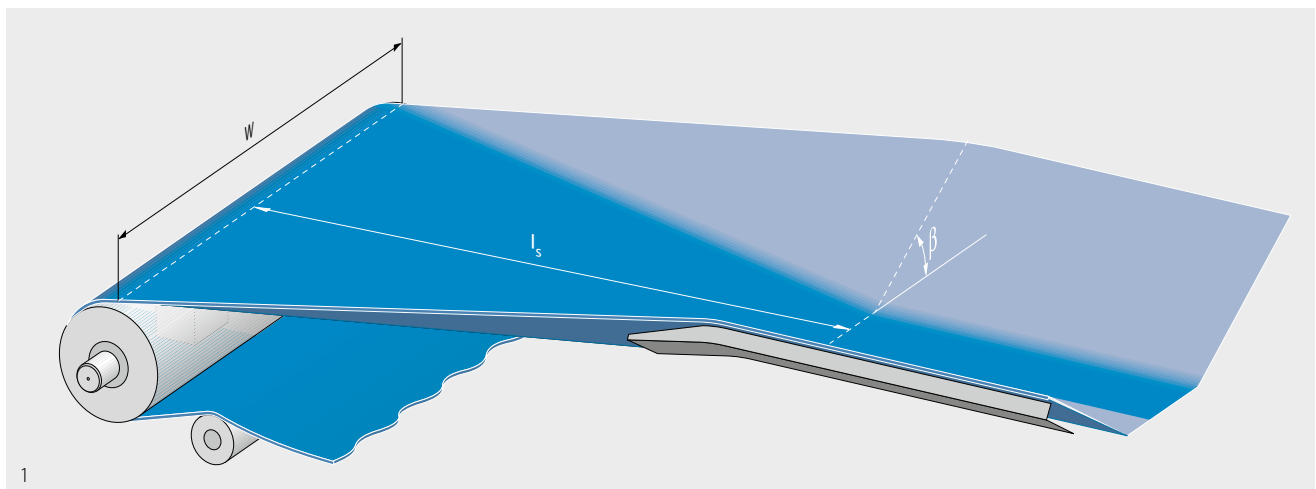

Fullsan series and trough shape

The possible trough shape and belt support design depend on the conveying task and the Fullsan type used.

Belt support for Fullsan CD (fig. 1)

- The belt can be supported by wearstrips, full-surface and by rollers (U-shaped, V-shaped or round).
- The profile rows in Fullsan Center Drive must lie at the bottom of the trough and not be part of the cupped/angled section of the belt.
- Use only materials according to the specifications in the materials table in section 2.1.
- For all types of belt support, observe the main dimensions in the drawings opposite and in section 2.3.
- Rollers should extend outwards at least to the edge of the belt. The spacing in the conveyor direction is normally between 400 mm and 700 mm (15.7 and 27.5 in).
- Integrate side guides if necessary.
- Make sure that the transitions in the regions at the beginning and end of the trough are well rounded.
- The top edges of the head and tail pulleys and the middle trough plane must lie in one plane.

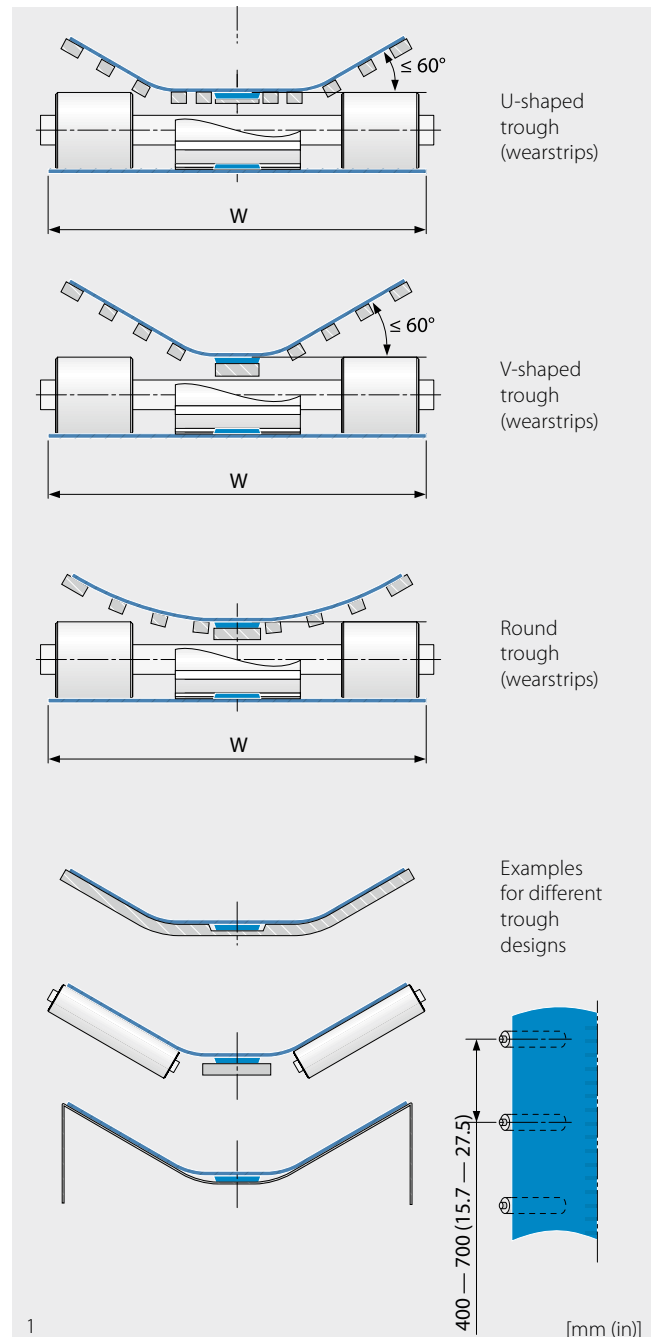

Principle diagrams for different trough designs

3.4 TROUGHED CONVEYORS

Belt support for Fullsán Flat (fig. 1)

- The belt can be supported by wearstrips, full-surface and by rollers (U-shaped, V-shaped or round).
- Use only materials according to the specifications in the materials table in section 2.1.
- For all types of belt support, observe the main dimensions in the drawings opposite and in section 2.3.
- Rollers should extend outwards at least to the edge of the belt. The spacing in the conveyor direction is normally between 400 mm and 700 mm (15.7 and 27.5 in).
- Integrate side guides if necessary.
- Make sure that the transitions in the regions at the beginning and end of the trough are well rounded.
- The top edges of the head and tail pulleys and the middle trough plane must lie in one plane. If the trough bottom is not supported by a wearstrip, a maximum sag of 30 mm (1.2 in) is permissible.

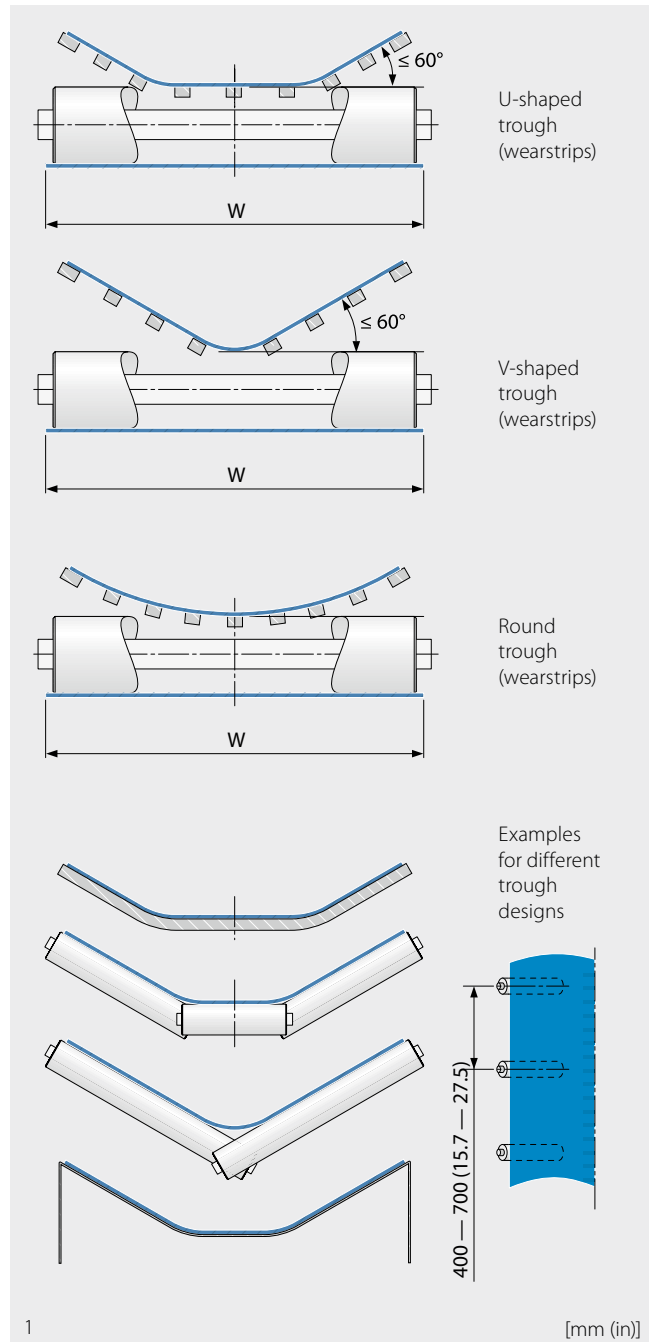

Principle diagrams for different trough designs



4 CALCULATIONS

4.1 Calculations

4.1 CALCULATIONS

In the following, we offer you a calculation guide for the simplified analysis of different conveyor designs. The forces and the admissible belt pull are checked.

The following calculations are used for positively driven Center Drive and Positive Drive belts. Flat belts are calculated in the same way as the Transilon or Extremultus types. The calculation guide for this can be found in "Conveyor Belt Calculation", Order No. 304 or in our B-Rex calculation program.

The essential input variables for a calculation are listed below.

Input variables

conveyor length
belt width
mass of conveyed product per meter belt length
belt speed
length of catenary sag
length of the tensioning range
conveyor layout
drive type
ambient conditions
operating conditions
sliding support material
belt type
side wall type
flight type
flight width
number of flights
sprocket type
sprockets per shaft
shaft design

Calculation of the adjusted belt length

Formulas

$$l_{30\%} = l_{c-c} + l_{tr} * 0.3$$

$$l_w = (\pi * D_0)$$

$$l_b = 2 * l_{30\%} + l_w + l_{sag}$$

Explanation

l_b = belt length [mm, in]

l_{ab} = adjusted belt length [mm, in]

l_{c-c} = conveyor length [mm, in]

l_{sag} = length of catenary sag [mm, in]

$l_{30\%}$ = conveyor length with 30% of the tensioning range [mm, in]

l_w = length of the wrap [mm, in]

l_{tr} = length of the tensioning range [mm, in]

l_{bp} = belt pitch [mm, in]

D_0 = pitch diameter of sprocket [mm, in]

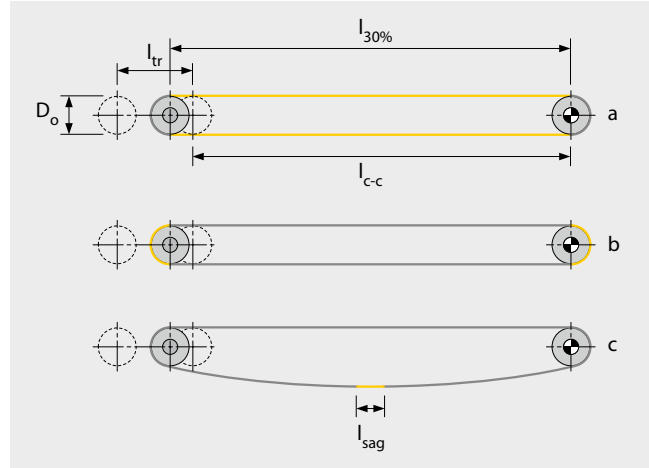

For complex conveyor systems, please speak to our customer service.

Adjustment of the belt length to the belt pitch

$l_{ab} = l_b / l_{bp} \Rightarrow$ round up to the nearest even number

\Rightarrow multiply the rounded number by the belt pitch $\Rightarrow l_{ab}$

4.1 CALCULATIONS

Calculation of the effective belt pull

Formulas

Calculating the mass of conveyed product:

$$m_p = m'_p * l_{c-c} \quad [\text{kg, lb}]$$

Calculating the mass of the flights:

$$m_{LP} = w_{LP} * m'_{LP} * n_{LP} \quad [\text{kg, lb}]$$

Calculating the mass of the side walls:

$$m_{LOP} = m'_{LOP} * l_{ab} \quad [\text{kg, lb}]$$

Calculating the mass of the tooth row for Center Drive:

$$m_{cd} = m'_{cd} * l_{ab} \quad [\text{kg, lb}]$$

Calculating the mass of entire belt:

$$m_B = w_B * l_{ab} * m'_B + m_{LP} + m_{LOP} + m_{cd} \quad [\text{kg, lb}]$$

Calculating the effective belt pull F_U :

$$\text{Horizontal conveyor: } F_U = \mu_s * g * (m_p + m_B) \quad [\text{N, lbf}]$$

Incline/Decline conveyor:

$$F_U = \mu_s * g * (m_p + m_B) \pm g * m_p * \sin(\alpha) \quad [\text{N, lbf}]$$

+ = incline - = decline

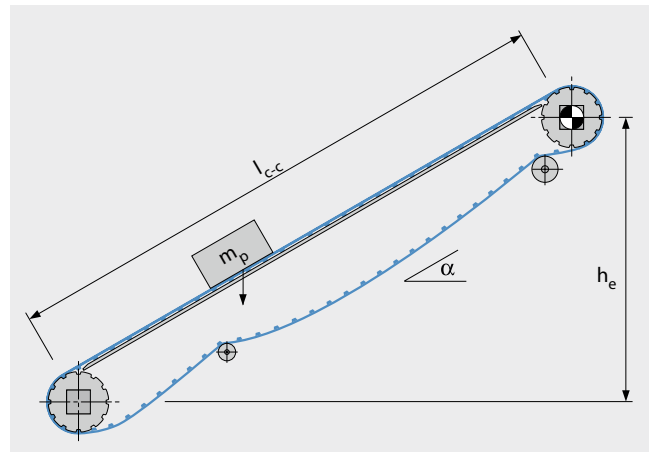
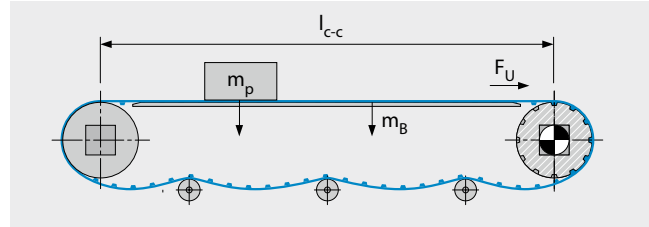

Explanation

F_U = effective belt pull [N, lbf]

m'_p = mass of conveyed product per meter belt length [kg/m, lb/ft]

m_p = mass of conveyed product [kg, lb]

m'_B = mass of belt per meter [kg/m², lb/ft²]

m_B = mass of entire belt in the conveyor [kg, lb]

m'_{LP} = mass of flight per millimeter [g/mm, lb/in]

m_{LP} = mass of flights over the entire length of the belt [kg, lb]

m'_{LOP} = mass of side wall per millimeter [g/mm, lb/in]

m_{LOP} = mass of a side wall over the entire length of the belt [kg, lb]

m'_{cd} = mass per meter row of teeth [g/mm, lb/in]

m_{cd} = mass of the row of teeth [kg, lb]

μ_s = coefficient of friction belt to slider

g = acceleration due to gravity [9.81 m/s², 1 lbf/lb]

α = angle of incline/decline

n_{LP} = number of flights

l_{c-c} = conveyor length [mm, in]

l_b = belt length [mm, in]

l_{ab} = adjusted belt length [mm, in]

w_{LP} = flight width [mm, in]

w_B = belt width [mm, in]

The coefficient of friction μ_s between belt and wear strip depends on various factors and is to be considered between 0.3 and 1.

For more information please contact customer service.

4.1 CALCULATIONS

Calculation of the adjusted belt pull F_{adj}

The measurable belt pull is higher if the optimal operating conditions cannot be obtained.

To take the operating conditions into account, the effective belt pull F_U is adjusted by the operational factor C_{Op}

Formula

Adjusted belt pull

$$F_{adj} = F_U * C_{Op} \quad [N, lbf]$$

Adjusted belt pull per millimeter of belt width

$$F'_{adj} = \frac{F_{adj}}{W_B} \quad [N/mm, lbf/ft]$$

Explanation

F_{adj} = adjusted belt pull [N, lbf]

F_U = effective belt pull [kg, lbf]

C_{Op} = operational factor

F'_{adj} = adjusted belt pull per millimeter of belt width [N/mm, lbf/ft]

W_B = belt width [mm, in]

Operational factor C_{Op}

$C_{Op} = 1 + \Sigma$
operating conditions + Σ
drive configuration

		C_{Op}
Operating conditions	Smooth operating conditions (smooth start)*	0
	Start-stop operation (start when loaded)**	+0.2
	Swan-neck conveyor	+0.4
Drive configuration	Head drive	0
	Lower head drive	+0.1
	Belt center drive (bi-directional)	+0.2
	Tail drive (pusher configuration)	+0.4

* A smooth start is always recommended.

** This is essential for starting under full load and frequent starts/stops.

Calculation of the admissible belt pull F'_{adm}

Temperature and belt speed can reduce the maximum belt pull capacity. To take this effect into account the admissible belt pull F'_{adm} is calculated with temperature and speed factor.

Formula

$$F'_{adm} = F'_{nom} * C_T * C_{Bv} \quad [\text{N/mm, lbf/ft}]$$

Explanation

F'_{adm} = admissible belt pull per millimeter of belt width [N/mm, lbf/ft]

F'_{nom} = nominal belt pull per millimeter of belt width [N/mm, lbf/ft]

C_T = temperature factor

C_{Bv} = speed factor

Temperature factor C_T

The tensile strength increases at temperatures below 20 °C but at the same time other mechanical properties are reduced at low temperatures. Therefore the C_T factor is set to 1.0 at temperatures below 20 °C. The temperatures relate to the actual belt temperature. Depending on the application and conveyor layout the temperature of the conveyed product may be different. For applications at temperatures below 0 °C, please contact our customer service.

Celsius [°C] from	Fahrenheit [°F] from	Temperature factor C_T	
		Belt material	
		non-reinforced	reinforced
-10	14	1	1
0	32	1	1
+10	50	1	1
+20	68	1	1
+30	86	1	1
+40	104	0.9	1
+50	122	0.8	0.9
+60	140	0.7	0.8
+70	158	0.6	0.7

Speed factor C_{Bv}

The belt speed has a significant influence on the capacity of the belt. As the speed increases, the tensions in the belt increase and reduce the usable belt pull capacity.

Belt speed in m/min (ft/min)	Speed factor C_{Bv}
5 (16.4)	0.95
10 (32.8)	0.9
15 (49.2)	0.85
20 (65.6)	0.8
25 (82)	0.75
30 (98.4)	0.7

4.1 CALCULATIONS

Validation of the belt selection

Criteria for determining belt selection

$$F'_{adj} < F'_{adm}$$

If this criteria is not fulfilled, change the belt series with a higher F'_{nom} value and repeat the calculation.

Formula

To calculate the utilization of belt strength use

$$\frac{F'_{adj}}{F'_{adm}} = \text{utilization} \quad [\%]$$

Explanation

F'_{adj} = adjusted belt pull per millimeter
of belt width [N/mm, lbf/ft]

F'_{adm} = admissible belt pull per millimeter
of belt width [N/mm, lbf/ft]

Shaft calculation – Shaft load

Formula

$$F_S = \sqrt{F_{adj}^2 + ((m_s + (m_{spr} * n_{spr})) * g)^2}$$

Explanation

F_S	= shaft load	[N, lbf]
F_{adj}	= adjusted belt pull	[N, lbf]
m_s	= mass of shaft	[kg, lb]
m_{spr}	= mass of a sprocket	[kg/lb]
n_{spr}	= number of sprockets per shaft	
g	= acceleration due to gravity	[9.81 m/s ² , 1 lbf/ft]
D_s, D_{in}, D_{out}	= diameter of shaft	[mm, in]
W_s	= edge length of square shaft	[mm, in]
t_s	= wall thickness of shaft	[mm, in]
l_s	= bearing center distance	[mm, in]

Material	Density ρ_s [kg/m ³]	Density ρ_s [lb/ft ³]
Carbon steel	7850	490
Stainless steel	8000	499
Aluminum	2700	169

Shaft type	Mass of shaft m_s
Round	$(\frac{D_s}{2})^2 * \pi * l_s * \rho_s$
Hollow round	$(\frac{D_{out}}{2} - \frac{D_{in}}{2})^2 * \pi * l_s * \rho_s$
Square	$(W_s)^2 * l_s * \rho_s$
Hollow square	$((W_s)^2 - (W_s - (2 * t_s))^2) * l_s * \rho_s$

4.1 CALCULATIONS

Shaft calculation – Torque

Formula

$$M = F_{adj} * \left(\frac{D_0}{2}\right)$$

Explanation

M = torque [Nm, lbf ft]

F_{adj} = adjusted belt pull [N, lbf]

D₀ = pitch diameter of sprocket [m, ft]

Shaft calculation – Deflection

Formula

$$y_s = \frac{5 * F_s * l_{db}^3}{384 * E * I} \quad [\text{mm, in}]$$

Explanation

y_s = shaft deflection [mm, in]

F_s = shaft load [N, lb]

l_{db} = bearing center distance [mm, in]

E = modulus of elasticity [MPa, psi]

I = area moment of inertia [mm⁴, in⁴]

W_s = edge length of square shaft [mm, in]

D_s, D_{in}
 D_{out} = diameter of shaft [mm, in]

t_s = wall thickness of shaft [mm, in]

Material	E in [MPa = $\frac{N}{\text{mm}^2}$]	E in [10 ⁶ psi]
Carbon steel	200000	29.01
Stainless steel	180000	26.11
Aluminum	70000	10.15

Shaft type	I
Round	$\frac{\pi * d_s^4}{64}$
Hollow round	$\pi * \frac{d_{out}^4 - d_{in}^4}{64}$
Square	$\frac{W_s^4}{12}$
Hollow square	$\frac{W_s^4 - (W_s - 2 * t_s)^4}{12}$

4.1 CALCULATIONS

Shaft calculation – Torsion

Formula

$$\phi = \frac{90 * F_{adj} * D_0 * l_{db}}{\pi * G * I_T}$$

Explanation

ϕ	= torsion angle in drive shaft	[°]
F_{adj}	= adjusted belt pull	[N, lb]
D_0	= pitch diameter of the sprocket	[mm, in]
l_{db}	= bearing center distance	[mm, in]
G	= modulus in shear strength	[MPa, psi]
I_T	= torsional inertial force	[mm ⁴ , in ⁴]
D_s, D_{in}		
D_{out}	= shaft diameter	[mm, in]

We recommend maintaining a torsion angle ϕ (phi) of < 0.25° per meter (0.076°/ft) of the shaft length. If the shaft twists too much the teeth may not engage properly

Material	G in [MPa = $\frac{N}{mm^2}$]	G in [10 ⁶ psi]
Carbon steel	80000	11.6
Stainless steel	75000	10.88
Aluminum	27000	3.92

Shaft type	I_T [mm ⁴]
Round	$\pi * \frac{d_s^4}{32}$
Hollow round	$\pi * \frac{d_{out}^4 * d_{in}^4}{32}$
Square	$0.141 * W_s^4$
Hollow square	$(W_s - t_s)^3 * t_s$

Shaft calculation – Power requirement

Formula

$$P_S = F_{adj} * v \quad [W] \quad (\text{metric}) \qquad P_S = \frac{F_{adj} * v}{33000} \quad [\text{hp}] \quad (\text{imperial})$$

Explanation

P_S = power at drive end of shaft [kW, hp]

F_{adj} = adjusted belt pull [N, lb]

v = belt speed [m/min, ft/min]

Please note that the calculated power is the net power necessary at the drive drum and does not take efficiency losses of e.g. the motor or gearbox into account. Furthermore it is recommend to install a motor with a reasonable reserve capacity.

Shaft calculation – Shaft revolutions

Formula

$$R_s = \frac{v}{D_0 * \pi}$$

Explanation

R_s = shaft revolutions [1/min]

v = belt speed [m/min, ft/min]

D_0 = pitch diameter of the sprocket [mm, in]

LEGAL NOTES

Forbo Siegling GmbH ("Forbo") provides this Engineering Manual for information purposes only. While Forbo endeavors that its recommendations, operating instructions, details and information on suitability and use of our products are as accurate and complete as possible, Forbo does not make any representation or warranty of any kind whatsoever, neither expressed nor implied, with respect to any information contained in this Engineering Manual unless otherwise expressly set forth in writing by duly authorized representatives of Forbo. It is your sole responsibility to perform appropriate testing of our products and their merchantability and fitness for a particular purpose, and Forbo does not accept any liability for any damages, including but not limited to property damages and personal injury, in connection with your reliance on any information contained in this Engineering Manual or any technical and/or other support which Forbo may have provided to you.

This Engineering Manual is Forbo property. Any reproduction, transmission or other use of this Engineering Manual or part(s) thereof is only permissible with Forbo's written consent.

Forbo reserves the right to modify the content of this Engineering Manual at any time and without prior notice to you. The latest version of this Engineering Manual can be downloaded from our website.

Siegling – total belting solutions

Committed staff, quality oriented organization and production processes ensure the constantly high standards of our products and services.

Forbo Movement Systems complies with total quality management principles. Our quality management system has ISO 9001 certification at all production and fabrication sites. What's more, many sites have ISO 14001 environmental management certification.



Ref. no. 444-2
03/26 - UDH - Reproduction of text or parts thereof only with our approval. Subject to change.



Our service – anytime, anywhere

Forbo Movement Systems employs around 2,300 people in its group of companies. Our products are manufactured in ten production facilities across the world.

You can find companies and agencies with warehouses and workshops in over 80 countries.

Service points are located in more than 300 places worldwide.

Forbo Siegling GmbH

Lilienthalstrasse 6/8, D-30179 Hannover

Phone +49 511 6704 0

www.forbo-siegling.com, siegling@forbo.com



MOVEMENT SYSTEMS