

EXCERPT FROM PROLINK ENGINEERING MANUAL

01/24 (Ref-No. 888)

siegling prolink
modular belts

SERIES 17

Straight running belts
Pitch 25.4 mm (1 in)

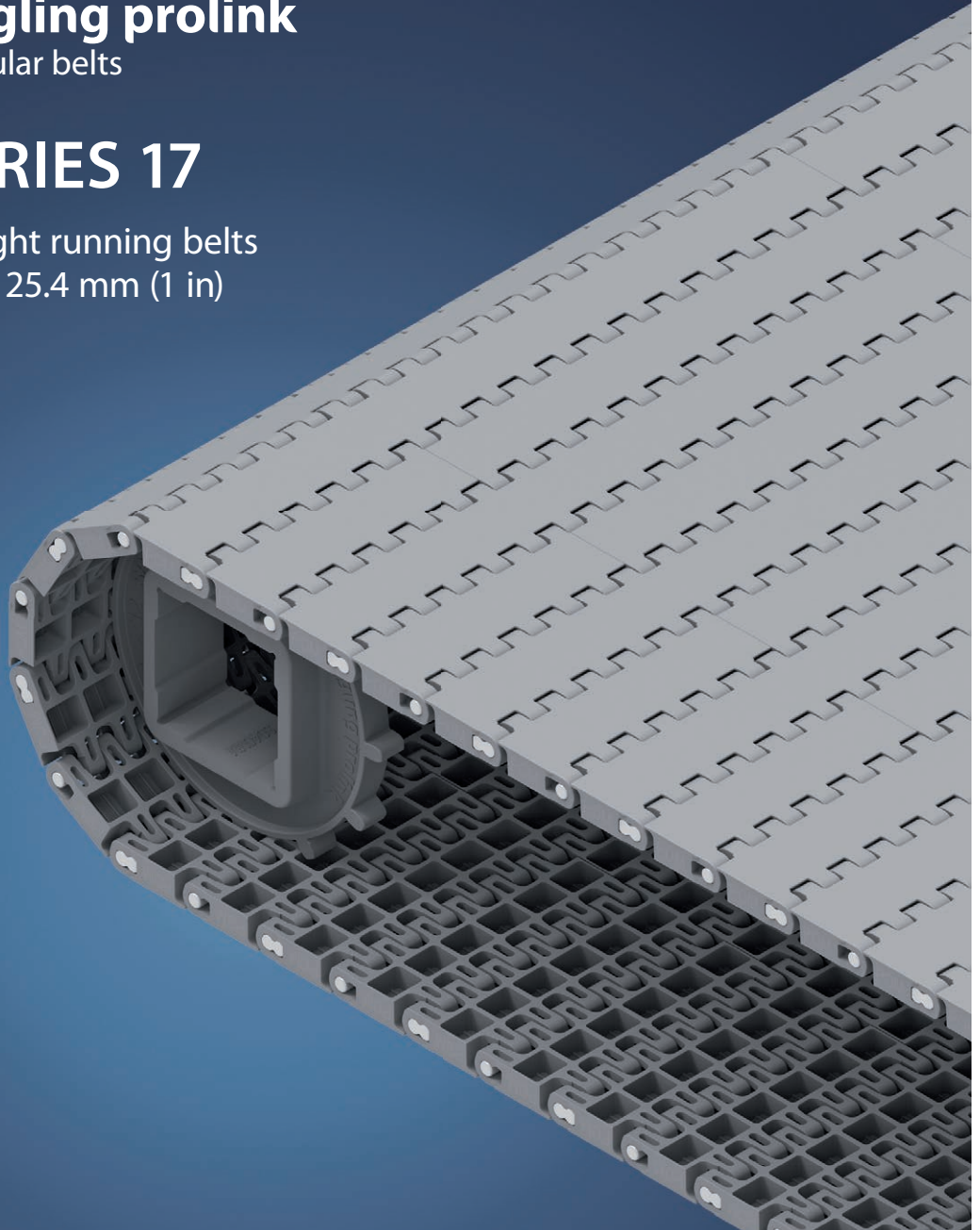

Forbo Siegling GmbH
Lilienthalstraße 6/8, D-30179 Hannover
Phone +49 511 6704 0
www.forbo-siegling.com, siegling@forbo.com

Ref. no. 888-2_1.2_S17

SERIES 17 | OVERVIEW

siegling prolink
modular belts

Straight running belts | Pitch 25.4 mm (1 in)

Medium to heavy-duty belts for industrial applications

Side view scale 1:1

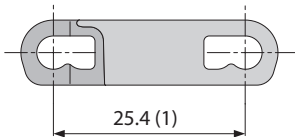

Design characteristics

- Closed hinge design provides high belt pull capacity
- A rigid module design allows optimal utilization of belt pull capacity relative to belt weight
- Robust design guarantees durability
- Unique 'keyhole' pin retention system ensures easy pin removal
- Flame retardant version available (PXX-HC – in line with DIN EN 13501-1)

Basic data

Pitch	25.4 mm (1 in)
Belt width min.	76.2 mm (3 in)
Width increments	12.7 mm (0.5 in)
Hinge pins	4.2 mm (0.17 in) made of plastic (PBT, PP)

Available surface pattern and opening area

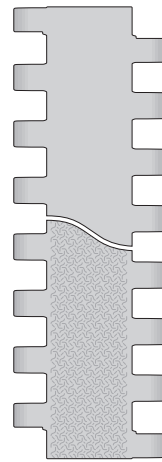

S17-0 FLT

Closed, smooth surface

S17-0 SRS

Closed, slip-resistant surface

Sprockets

in different sizes with round or square bore

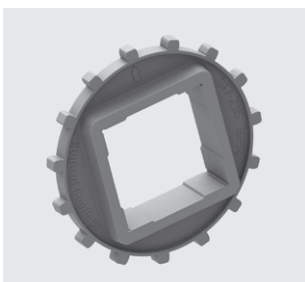

Profiles

for incline conveyors

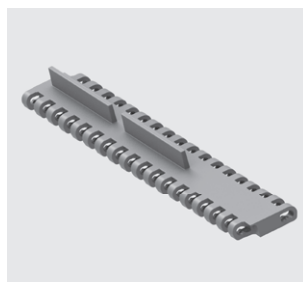

SERIES 17 | BELT TYPES

siegling prolink
modular belts

Straight running belt | Pitch 25.4 mm (1 in)

S17-0 FLT | 0% Opening | Flat top

Closed, smooth surface | Flat top surface

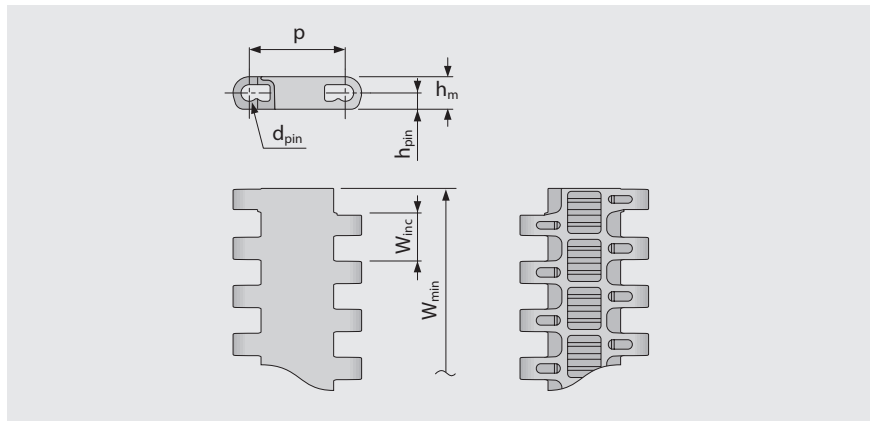
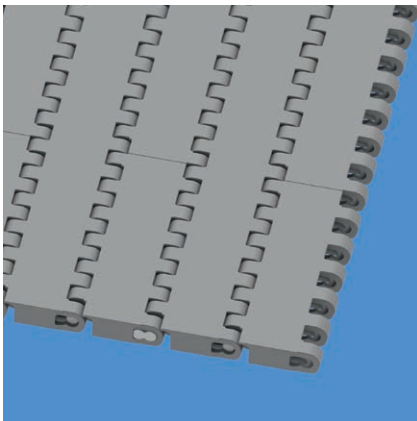

Belt dimensions

	p	d _{pin}	h _m	h _{pin}	h _s	W _{min}	W _{inc}	W _{tol}	Minimum flex radii ¹⁾				
	Pitch	Pin Ø	Thickness	Pin position	Height	Width min.	Width Increment	Width tolerance [%]	r1 C _c x W _B	r2	r3	r4	r5
mm	25.4	4.2	8.6	4.3	0.0	76.2	12.7	±0.2	–	25.4	50.8	76.2	25.4
inch	1.0	0.17	0.34	0.17	0.0	3.0	0.5	±0.2	–	1.0	2.0	3.0	1.0

Available standard materials³⁾

Belt		Pin		Nominal belt pull, straight		Weight		Width deviation	Temperature		Certificates ²⁾	
Material	Color	Material	Color	[N/mm]	[lb/ft]	[kg/m ²]	[lb/ft ²]	[%]	[°C]	[°F]	FDA	EU
POM	LG	PBT	UC	32	2193	6.5	1.33	-0.09	-45/90	-49/194	●	●
PP	BL	PP	BL	18	1233	4.2	0.86	0.35	5/100	41/212	●	●

Mold to width available in: 76 mm (3.0 in), 229 mm (9.0 in)

■ BL (Blue), ■ LG (Light gray), □ UC (Uncolored)

All measurements and tolerances apply at 21 °C; for temperature deviations please see Prolink manual chapter 4.4 "Temperature influence".

All imperial dimensions (inches) are rounded off.

¹⁾ Flex radii: r1 = side flex, r2 = front flex on roller, r3 = back flex on load bearing roller, r4 = back flex on Hold Down shoe, r5 = back flex on roller

²⁾ Complies with FDA 21 CFR | Complies with (EU) 10/2011 and (EC) 1935/2004 regulations regarding the raw materials used and the migration thresholds | Complies with Japanese MHLW Notification 370

● = available | – = not available | empty cells = not tested

³⁾ More materials and colors on request



MOVEMENT SYSTEMS

SERIES 17 | BELT TYPES

siegling prolink
modular belts

Straight running belt | Pitch 25.4 mm (1 in)

S17-0 SRS | 0% Opening | Slip-resistant surface

Closed surface | Slip-resistant surface, pleasant to walk and kneel on

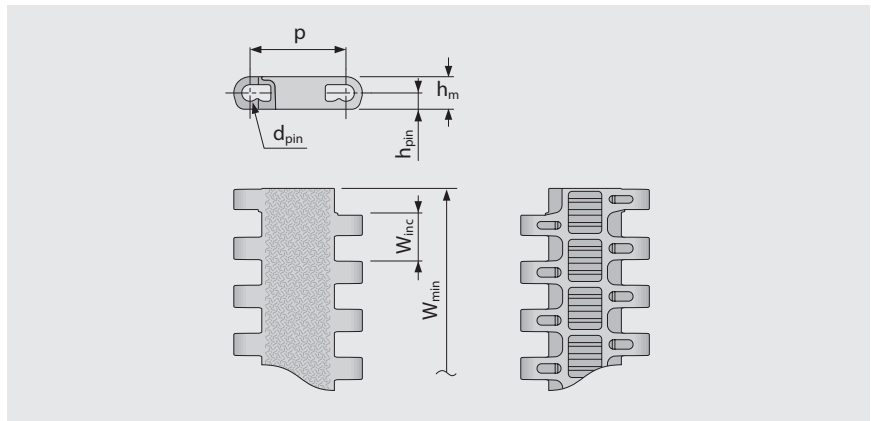
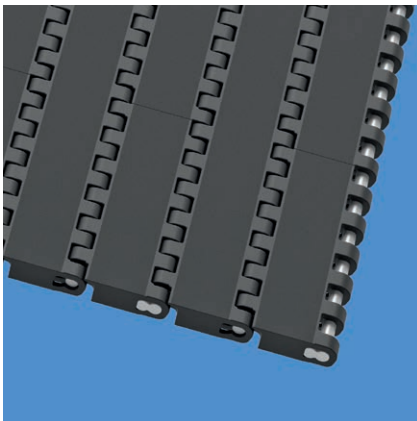

Belt dimensions

	p	d _{pin}	h _m	h _{pin}	h _s	W _{min}	W _{inc}	W _{tol}	Minimum flex radii ¹⁾				
	Pitch	Pin Ø	Thickness	Pin position	Height	Width min.	Width Increment	Width tolerance [%]	r1 C _c x W _B	r2	r3	r4	r5
mm	25.4	4.2	8.6	4.3	0.0	76.2	12.7	±0.2	–	25.4	50.8	76.2	25.4
inch	1.0	0.17	0.34	0.17	0.0	3.0	0.5	±0.2	–	1.0	2.0	3.0	1.0

Mold to order belts³⁾

Belt		Pin		Nominal belt pull, straight		Weight		Width deviation	Temperature		Certificates ²⁾
Material	Color	Material	Color	[N/mm]	[lb/ft]	[kg/m ²]	[lb/ft ²]	[%]	[°C]	[°F]	Flame retardant
PXX-HC	BK	PBT	UC	14	822	5.7	1.17	0.35	5/100	41/212	●

Mold to width available in: 76 mm (3.0 in), 229 mm (9.0 in)

■ BK (Black), □ UC (Uncolored)

All measurements and tolerances apply at 21 °C; for temperature deviations please see Prolink manual chapter 4.4 "Temperature influence".

All imperial dimensions (inches) are rounded off.

¹⁾ Flex radii: r1 = side flex, r2 = front flex on roller, r3 = back flex on load bearing roller, r4 = back flex on Hold Down shoe, r5 = back flex on roller

²⁾ Complies with DIN EN 13501-1 Cfl-s1 (and DIN 4102 B1)

● = available | – = not available | empty cells = not tested

³⁾ More materials and colors on request



MOVEMENT SYSTEMS

SERIES 17 | SPROCKETS

siegling prolink
modular belts

Straight running belt | Pitch 25.4 mm (1 in)

S17 SPR | Sprockets

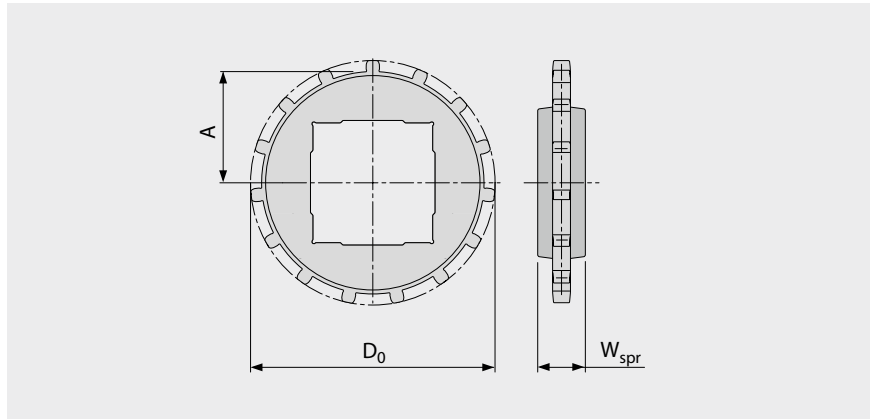
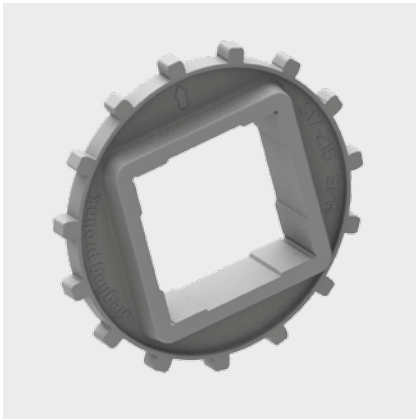

Main dimensions

Sprocket size (Number of teeth)		Z12	Z15	Z18	Z19
W _{spr}	mm	24.0	24.0	24.0	24.0
	inch	0.94	0.94	0.94	0.94
D ₀	mm	99.7	123.2	148.0	156.1
	inch	3.93	4.85	5.83	6.15
A _{max}	mm	45.8	57.4	70.0	73.9
	inch	1.80	2.26	2.76	2.91
A _{min}	mm	44.0	56.0	68.7	72.7
	inch	1.73	2.20	2.70	2.86

Shaft bores (● = Round, ■ = Square)

30	mm	●			
40	mm	■		●/■	
60	mm		■	■	■
80	mm				■
1.25	inch	●			
1.5	inch	■		●/■	
2.5	inch		■	■	■

Material: PA, Color: LG

■ LG (Light gray)

All measurements and tolerances apply at 21 °C; for temperature deviations please see Prolink manual chapter 4.4 "Temperature influence".

All imperial dimensions (inches) are rounded off.

For detailed sprocket and shaft dimensions see appendix 6.3

Number of sprockets (sprocket spacing distance) see chapter 3.2

SERIES 17 | PROFILES

Straight running belt | Pitch 25.4 mm (1 in)

siegling prolink
modular belts

S17-0 FLT PMU I83

Lateral rib with indent 83 mm (3.3 in) to carry goods with small profiles

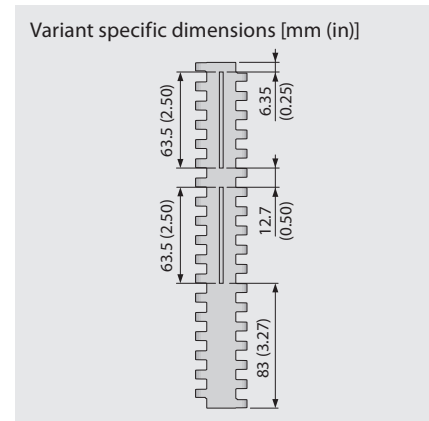
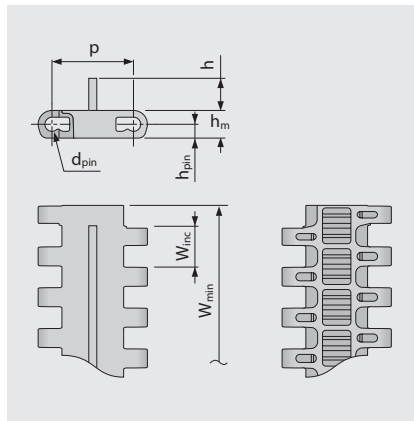

Basic data

Material	Color	Height (h)
		10 mm 0.39 inch
POM	LG	●

Molded width: 228.6 mm (9.0 in)

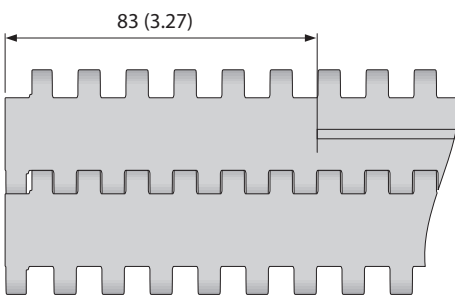

Standard configuration S17-0 FLT PMU I83

■ LG (Light gray)

All measurements and tolerances apply at 21 °C; for temperature deviations please see Prolink manual chapter 4.4 "Temperature influence".

All imperial dimensions (inches) are rounded off.

Note: Use of accessory in a belt may impact on the minimum design radii. Please see chapter 6.3 for further information.



MOVEMENT SYSTEMS

LEGEND

① Series	
S1 ... S18	

② Open area/Sprocket size	
Percentage open area	
Format: xx	
E.g. 20 = 20%	
For sprockets: number of teeth	
Format: "Z"xx	
E.g. Z12 = 12 teeth	

③ Surface pattern	
BSL	Base module for slider
CTP	Cone top
CUT	Curved top
FLT	Flat top (smooth)
FRT-OG	Friction top without High Grip insert
FRT(X)	Friction top (Design X)
GRT	Grid top
HDK	High Deck
LRB	Lateral rib
MOD	Modified module shape
NCL	No cling
NPY	Negative pyramid
NSK	Non skid
NSK2	Non skid, nonwoven variant
NTP	Nub top (round studs)
PRR	Pin Retained Rollers
RAT	Radius top
RRB	Raised rib
RSA	Reduced surface area
RTP	Roller top
SRS	Slip-resistant surface

④ Type	
BPU	Bucket profile
CAP	Pin lock & belt edge sealing
CCW	Counter clockwise
CLP	Clip
CM	Center module
CW	Clockwise
FPL	Finger plate
HDT	Hold Down Tab
IDL	Idler
PIN	Coupling rod
PMC	Profile module center
PMU	Profile module universal
PSP	ProSnap
RI	High Grip insert
RTR	Retaining ring
SG	Module with sideguard
SLI	Slider
SML	Side module, left
SMR	Side module, right
SMU	Side module, universal/both sides
SPR	Sprocket
TPL	Turning panel, left
TPR	Turning panel, right
UM	Universal module
WSC	Wheel Stopper Center
WSS	Wheel Stopper Side

⑤ Style	
1.7	1.7 collapse factor
2.2	2.2 collapse factor
2.2 G	2.2 collapse factor, guided
A90	Angle 90° to conveying direction
BT	Bearing tab
DR	Double row sprocket
F1, F2, F3 ...	Collapse factor modules
G	Guided
GT	Guiding tabs
HD	Hold Down
Ixx	xx = indent in mm
RG	Reversed guided
SG	Side guard
SP	Split sprocket
ST	Strong

⑥ Material	
PA	Polyamide
PA-HT	Polyamide high temperature
PBT	Polybutylenterephthalate
PE	Polyethylene
PE-I	PE impact resistant
PE-MD	PE metal detectable
PLX	Wear & impact improved polymer
POM	Polyoxymethylene (Polyacetal)
POM-CR	POM cut resistant
POM-HC	POM highly conductive
POM-MD	POM metal detectable
POM-PE	POM side modules + PE center modules
POM-PP	POM side modules + PP center modules
PP	Polypropylene
PP-MD	PP metal detectable
PP-SW	PP steam and hot water resistant
PXX-HC	Self-extinguishing highly conductive material
R1	TPE 80 Shore A, PP
R2	EPDM 80 Shore A, vulcanized
R3	TPE 70 Shore A, POM
R4	TPE 86 Shore A, PP
R5	TPE 52 Shore A, PP
R6	TPE 63 Shore A, POM
R7	TPE 50 Shore A, PP
R8	TPE 55 Shore A, PE
SER	Self-extinguishing TPE
SS	Stainless steel
TPC1	Thermoplastic Copolyester
-HA	Supports the HACCP concept
-HW	High Wear resistant material

⑦ Color*		
AT	Anthracite	
BG	Beige	
BK	Black	
BL	Blue	
DB	Dark blue	
GN	Green	
LB	Light blue	
LG	Light gray	
OR	Orange	
RE	Red	
TQ	Turquoise	
UC	Uncolored	
WT	White	
YL	Yellow	

⑧ Height/Diameter/ Bore size and style	
Height in mm (in)	Format: Hxxx
Pin diameter in mm (in)	Format: Dxxx
Bore size: SQ (= square) or RD (= round) either in mm or inches	Format: SQxxMM or RDxxIN

⑨ Length/Width	
Pins Length in mm (in)	Format: Lxxx
Module width in mm (in)	Format: Wxxx

* For each series' standard colors please refer to the table of materials for each belt (chapter 1.2). A number of other colors are available on request. Colors can vary from the original due to the print, production processes or material used.