

# SERIES 8 | SPLIT SPROCKETS

siegling prolink  
modular belts

Straight running belt | Pitch 25.4 mm (1 in)

## S8 SPR-SP | Split Sprockets

Easy assembly without dismounting shaft | Deep tooth engagement for heavy loads

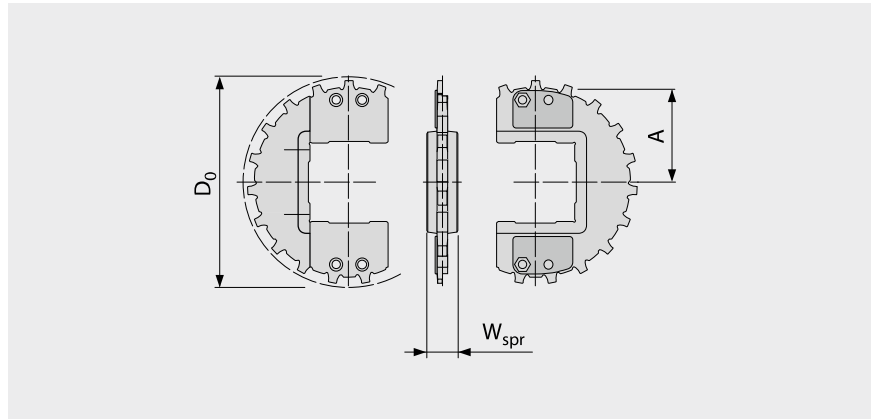

### Main dimensions

Sprocket size (Number of teeth)		Z12	Z16	Z19	Z21	Z22
W <sub>spr</sub>	mm	25.0	25.0	25.0	25.0	25.0
	inch	0.98	0.98	0.98	0.98	0.98
D <sub>0</sub>	mm	99.5	132.2	155.7	172.9	181.2
	inch	3.92	5.20	6.13	6.81	7.13
A <sub>max</sub>	mm	44.5	60.8	72.6	81.3	85.4
	inch	1.75	2.39	2.86	3.20	3.36
A <sub>min</sub>	mm	43.0	59.7	71.6	80.2	84.5
	inch	1.69	2.35	2.82	3.16	3.33

### Shaft bores (● = Round, ■ = Square)

40	mm	■	●/■	●/■	■	
60	mm		●/■	●/■	■	
90	mm					■
1	inch	●				
1.5	inch		●/■	●/■	■	
2.5	inch		●/■	●/■	■	

Material: PA, Color: LG

Mold to order: Material: PP, Color: WT

■ LG (Light gray), □ WT (White)

All measurements and tolerances apply at 21 °C; for temperature deviations please see Prolink manual chapter 4.4 "Temperature influence".

All imperial dimensions (inches) are rounded off.

For detailed sprocket and shaft dimensions see appendix 6.3

Number of sprockets (sprocket spacing distance) see chapter 3.2



MOVEMENT SYSTEMS