

# EXCERPT FROM PROLINK ENGINEERING MANUAL

01/20 (Ref-No. 888)

**siegling prolink**  
modular belts

## SERIES 6.1

Straight running belts  
Pitch 50 mm (1.97 in)

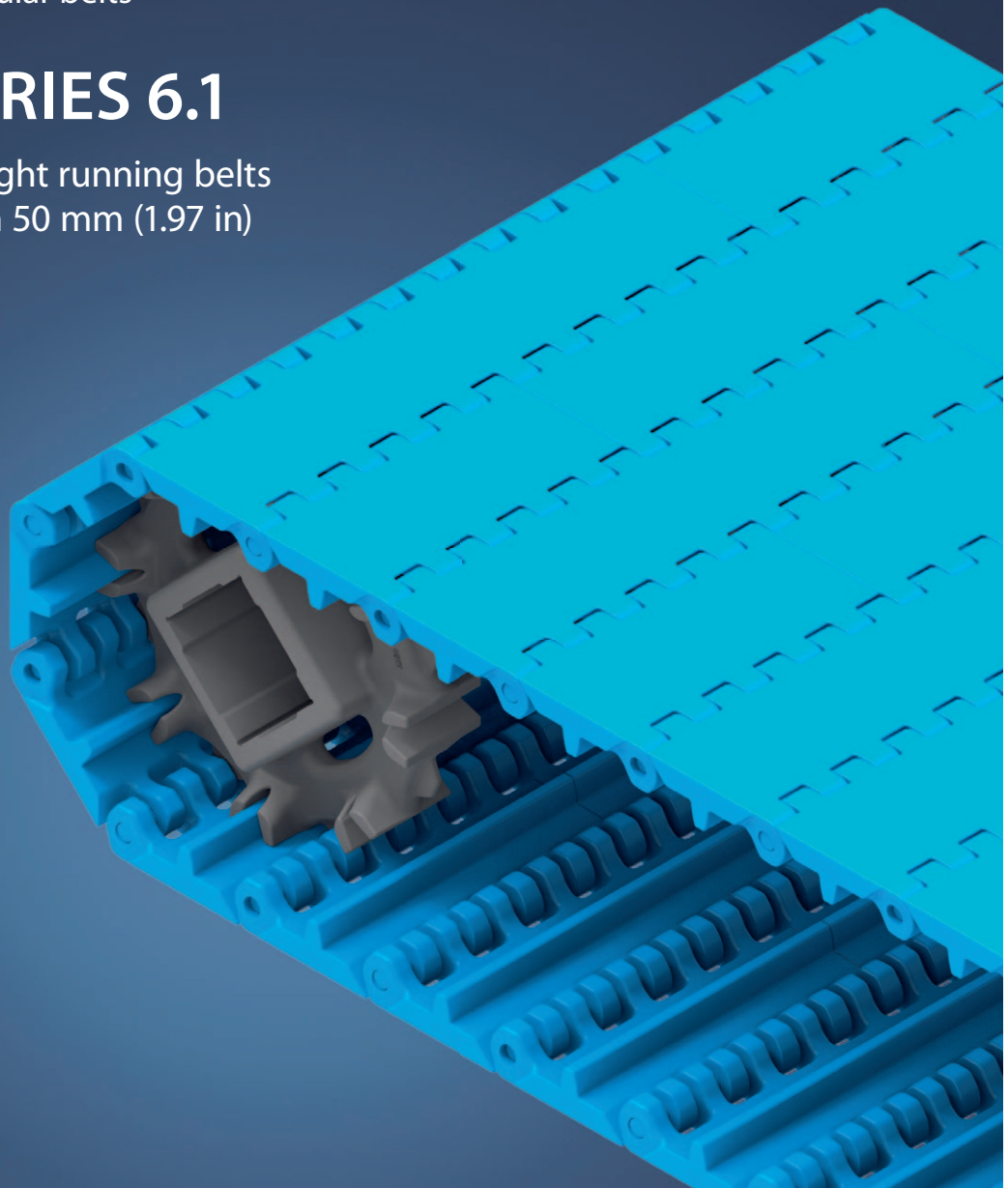

**Forbo Siegling GmbH**  
Lilienthalstraße 6/8, D-30179 Hannover  
Phone +49 511 6704 0  
[www.forbo-siegling.com](http://www.forbo-siegling.com), [siegling@forbo.com](mailto:siegling@forbo.com)

Ref. no. 888-2\_1.2\_S6.1

# SERIES 6.1 | OVERVIEW

siegling prolink  
modular belts

Straight running belts | Pitch 50 mm (1.97 in)

Belts for medium to heavy-duty, hygiene-critical applications

## Side view scale 1:1

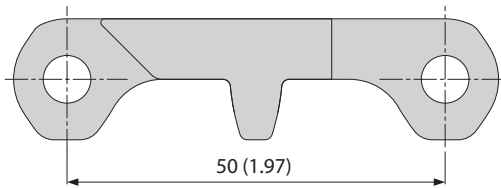

## Design characteristics

- Wide modules and eyelets for less soiling
- Hinges that open wide, wide channels on the underside and a continuous drive bar for an easy-to-clean design
- Robust design and smooth, cut-resistant surface (depending on material)
- Special sprocket design with enhanced tooth engagement for excellent force transmission

## Basic data

Pitch	50 mm (1.97 in)
Belt width min.	40 mm (1.57 in)
Width increments	20 mm (0.8 in)
Hinge pins	Made of plastic (PE, PP, POM-MD, PBT)

## Available surface pattern and opening area

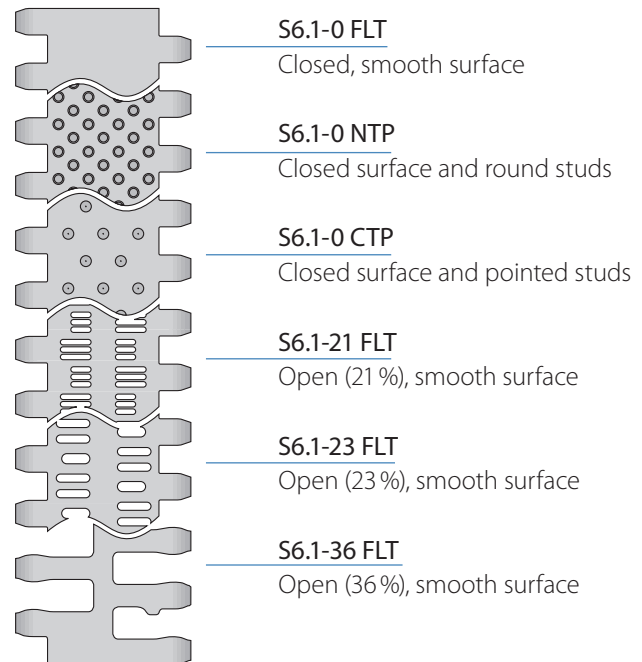

NSF-compliant from these certified Forbo plants:  
Huntersville (USA), Malacky (Slovakia), NSW (Australia),  
Tlalnepantla (Mexico), Saint-Petersburg (Russia),  
Shizuoka (Japan), Maharashtra (India)

## Sprockets

in different sizes with round or square sprocket bore



## Profiles

in different heights and designs for inclines.

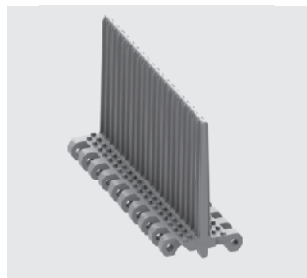

## Side guards

in different heights for retention of bulk products



## Hold Down Tabs

Hold Down Tabs for additional guiding



# SERIES 6.1 | BELT TYPES

siegling prolink  
modular belts

Straight running belt | Pitch 50 mm (1.97 in)

## S6.1-0 FLT | 0% Opening | Flat top

Closed, smooth surface | Flat top surface | Easy-to-clean

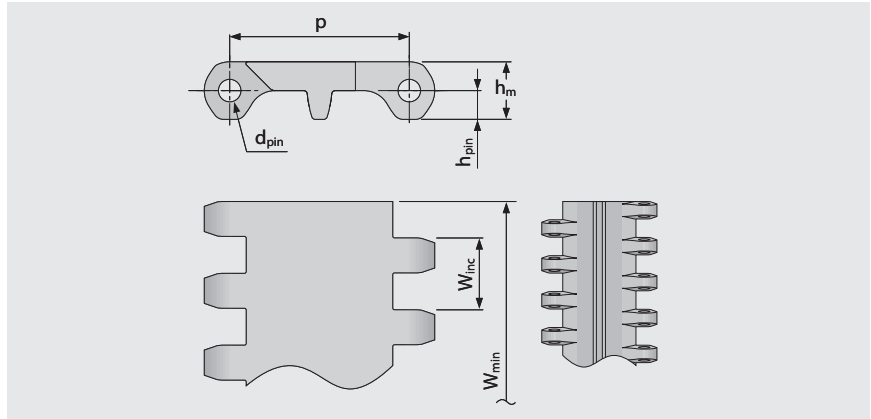
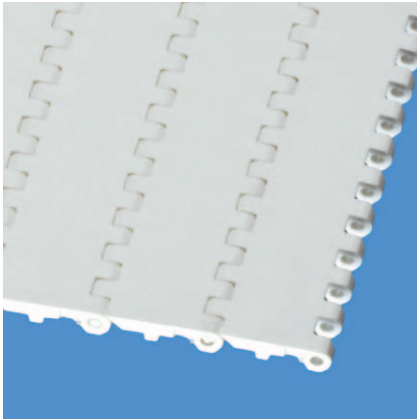

### Belt dimensions

	p	d <sub>pin</sub>	h <sub>m</sub>	h <sub>pin</sub>	h <sub>s</sub>	W <sub>min</sub>	W <sub>inc</sub>	W <sub>tol</sub>	Minimum flex radii <sup>1)</sup>				
	Pitch	Pin Ø	Thickness [mm]	Pin position [mm]	Height [mm]	Width min. [mm]	Width Increment [mm]	Width tolerance [%]	r1	r2	r3	r4	r5
mm	50.0	6.0	16.0	8.0	0.0	40.0	20.0	±0.2	-	50.0	100.0	150.0	50.0
inch	1.97	0.24	0.63	0.31	0.0	1.57	0.79	±0.2	-	1.97	3.94	5.91	1.97

### Available standard materials<sup>4)</sup>

Belt		Pin		Nominal belt pull, straight		Weight		Width deviation [%]	Temperature		Certificates	
Material	Color	Material	Color	[N/mm]	[lb/ft]	[kg/m <sup>2</sup> ]	[lb/ft <sup>2</sup> ]		[°C]	[°F]	FDA <sup>2)</sup>	EU <sup>3)</sup>
PE	WT/LB	PE	WT/LB	13	891	9.4	1.93	-0.65	-70/65	-94/149	●	●
POM	WT/LB	PBT	UC/LB	30	2056	13.4	2.74	-0.65	-45/90	-49/194	●	●
POM-CR	WT/LB	PBT	UC/LB	30	2056	13.4	2.74	-0.65	-45/90	-49/194	●	●
PP	WT/LB	PP	WT/LB	18	1233	8.3	1.7	-0.0	5/100	41/212	●	●
PE-MD	BL	POM-MD	BL	13	891	9.8	2.01	-0.65	-70/65	-94/149	●	●
POM-MD	BL	POM-MD	BL	30	2056	13.7	2.81	-0.65	-45/65	-49/149	●	●
PP-MD	BL	PP-MD	BL	18	1233	9.0	1.84	-0.0	5/100	41/212	●	●

### Mold to order belts

PA*	BL	PBT	UC	30	2056	12.9	2.64	-0.0	-40/120	-40/248	●	●
TPC1	LB	PBT	UC	13	891	11.6	2.38	-0.65	-25/80	-13/176	●	●

Mold to width available in: 100 mm (3.94 in), 140 mm (5.51 in), 200 mm (7.87 in), 220 mm (8.66 in), 400 mm (15.75 in)

\* Values valid for dry applications (RH <50%). Belts in PA material will absorb water in wet environments, causing them to expand and reduce the nominal belt pull capacity.

■ BL (Blue), ■ LB (Light blue), □ UC (Uncolored), □ WT (White)

All measurements and tolerances apply at 21 °C; for temperature deviations please see Prolink manual chapter 4.4 "Temperature influence".

All imperial dimensions (inches) are rounded off.

<sup>1)</sup> Flex radii: r1 = side flex, r2 = front flex on roller, r3 = back flex on load bearing roller, r4 = back flex on Hold Down shoe, r5 = back flex on roller

<sup>2)</sup> Complies with FDA 21 CFR

<sup>3)</sup> Complies with (EU) 10/2011 and (EC) 1935/2004 regulations regarding the raw materials used and the migration thresholds

<sup>4)</sup> More materials and colors on request



MOVEMENT SYSTEMS

# SERIES 6.1 | BELT TYPES

siegling prolink  
modular belts

Straight running belt | Pitch 50 mm (1.97 in)

## S6.1-0 NTP | 0% Opening | Nub top (round studs)

Closed surface and round studs | 6% contact area | Nub top surface for good release of wet and sticky products | Easy-to-clean

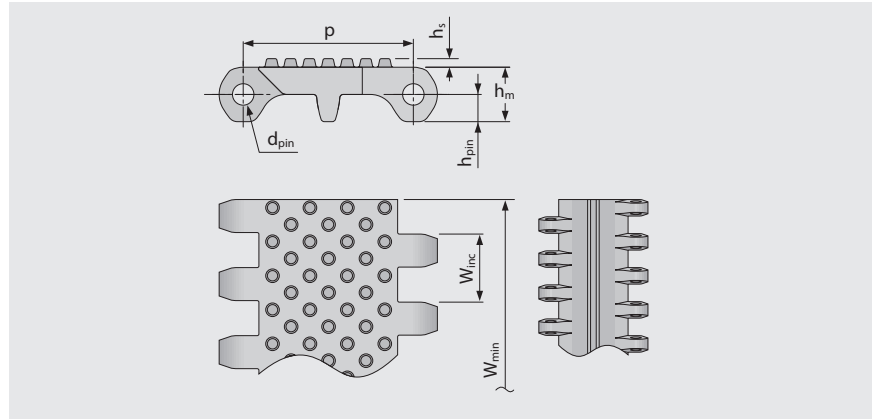
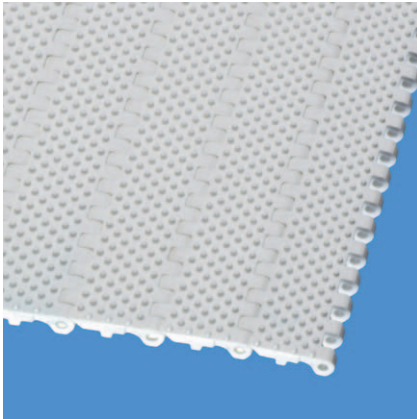

### Belt dimensions

	p	d <sub>pin</sub>	h <sub>m</sub>	h <sub>pin</sub>	h <sub>s</sub>	W <sub>min</sub>	W <sub>inc</sub>	W <sub>tol</sub>	Minimum flex radii <sup>1)</sup>				
	Pitch	Pin Ø	Thickness [mm]	Pin position [mm]	Height [mm]	Width min. [mm]	Width Increment [mm]	Width tolerance [%]	r1	r2	r3	r4	r5
mm	50.0	6.0	16.0	8.0	2.5	40.0	20.0	±0.2	–	50.0	100.0	150.0	50.0
inch	1.97	0.24	0.63	0.31	0.1	1.57	0.79	±0.2	–	1.97	3.94	5.91	1.97

### Available standard materials<sup>4)</sup>

Belt		Pin		Nominal belt pull, straight		Weight		Width deviation	Temperature		Certificates	
Material	Color	Material	Color	[N/mm]	[lb/ft]	[kg/m <sup>2</sup> ]	[lb/ft <sup>2</sup> ]	[%]	[°C]	[°F]	FDA <sup>2)</sup>	EU <sup>3)</sup>
PE	WT	PE	WT	13	891	9.6	1.97	-0.65	-70/65	-94/149	●	●
PE	LB	PE	LB	13	891	9.6	1.97	-0.65	-70/65	-94/149	●	●
POM	LB	PBT	LB	30	2056	13.7	2.81	-0.65	-45/90	-49/194	●	●

Mold to order belts												
PP		PP		18	1233	8.4	1.72	0.0	5/100	41/212	–	–

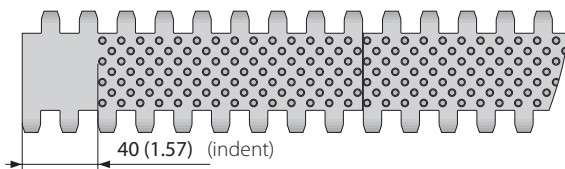

Also available with molded indent 40 mm (1.57 in)

Mold to width available in: 100 mm (3.94 in), 200 mm (7.87 in), 400 mm (15.75 in)

■ LB (Light blue), □ WT (White)

All measurements and tolerances apply at 21 °C; for temperature deviations please see Prolink manual chapter 4.4 "Temperature influence".

All imperial dimensions (inches) are rounded off.

<sup>1)</sup> Flex radii: r1 = side flex, r2 = front flex on roller, r3 = back flex on load bearing roller, r4 = back flex on Hold Down shoe, r5 = back flex on roller

<sup>2)</sup> Complies with FDA 21 CFR

<sup>3)</sup> Complies with (EU) 10/2011 and (EC) 1935/2004 regulations regarding the raw materials used and the migration thresholds

<sup>4)</sup> More materials and colors on request



MOVEMENT SYSTEMS

# SERIES 6.1 | BELT TYPES

siegling prolink  
modular belts

Straight running belt | Pitch 50 mm (1.97 in)

## S6.1-0 CTP | 0% Opening | Cone top (pointed studs)

Closed surface and pointed studs | Cone top surface pattern for superior grip | Easy-to-clean

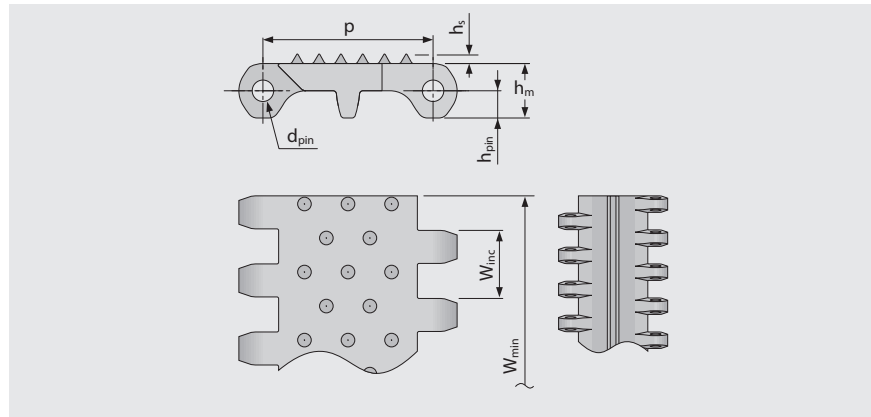
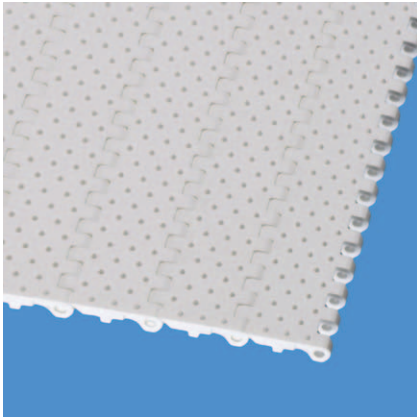

### Belt dimensions

	p	d <sub>pin</sub>	h <sub>m</sub>	h <sub>pin</sub>	h <sub>s</sub>	W <sub>min</sub>	W <sub>inc</sub>	W <sub>tol</sub>	Minimum flex radii <sup>1)</sup>				
	Pitch	Pin Ø	Thickness [mm]	Pin position [mm]	Height [mm]	Width min. [mm]	Width Increment [mm]	Width tolerance [%]	r1	r2	r3	r4	r5
mm	50.0	6.0	16.0	8.0	2.8	40.0	20.0	±0.2	–	50.0	100.0	150.0	50.0
inch	1.97	0.24	0.63	0.31	0.11	1.57	0.79	±0.2	–	1.97	3.94	5.91	1.97

### Available standard materials<sup>4)</sup>

Belt		Pin		Nominal belt pull, straight		Weight		Width deviation [%]	Temperature		Certificates	
Material	Color	Material	Color	[N/mm]	[lb/ft]	[kg/m <sup>2</sup> ]	[lb/ft <sup>2</sup> ]		[°C]	[°F]	FDA <sup>2)</sup>	EU <sup>3)</sup>
POM	WT	PBT	UC	30	2056	13.5	2.77	-0.65	-45/90	-49/194	●	●

Mold to order belts												
PE		PE		13	891	9.5	1.95	-0.65	-70/65	-94/149	–	–

Mold to width available in: 400 mm (15.75 in)

UC (Uncolored),  WT (White)

All measurements and tolerances apply at 21 °C; for temperature deviations please see ProLink manual chapter 4.4 "Temperature influence".

All imperial dimensions (inches) are rounded off.

<sup>1)</sup> Flex radii: r1 = side flex, r2 = front flex on roller, r3 = back flex on load bearing roller, r4 = back flex on Hold Down shoe, r5 = back flex on roller

<sup>2)</sup> Complies with FDA 21 CFR

<sup>3)</sup> Complies with (EU) 10/2011 and (EC) 1935/2004 regulations regarding the raw materials used and the migration thresholds

<sup>4)</sup> More materials and colors on request



MOVEMENT SYSTEMS

# SERIES 6.1 | BELT TYPES

siegling prolink  
modular belts

Straight running belt | Pitch 50 mm (1.97 in)

## S6.1-21 FLT | 21 % Opening | Flat top

Open area (21 %) for excellent air circulation and drainage | 72% contact area (Largest opening: 1.9 x 11 mm/0.07 x 0.43 in) | Smooth surface | Easy-to-clean

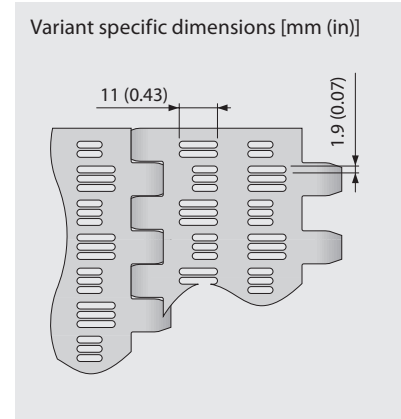
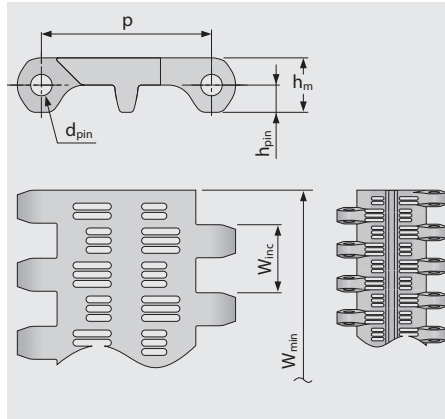
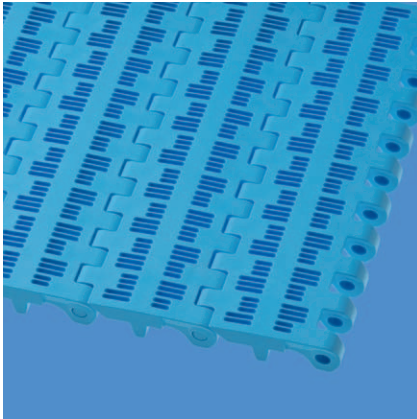

### Belt dimensions

	p	d <sub>pin</sub>	h <sub>m</sub>	h <sub>pin</sub>	h <sub>s</sub>	W <sub>min</sub>	W <sub>inc</sub>	W <sub>tol</sub>	Minimum flex radii <sup>1)</sup>				
	Pitch	Pin Ø	Thickness [mm]	Pin position [mm]	Height [mm]	Width min. [mm]	Width Increment [mm]	Width tolerance [%]	r1	r2	r3	r4	r5
mm	50.0	6.0	16.0	8.0	0.0	40.0	20.0	±0.2	-	50.0	100.0	150.0	50.0
inch	1.97	0.24	0.63	0.31	0.0	1.57	0.79	±0.2	-	1.97	3.94	5.91	1.97

### Available standard materials<sup>4)</sup>

Belt		Pin		Nominal belt pull, straight		Weight		Width deviation [%]	Temperature		Certificates	
Material	Color	Material	Color	[N/mm]	[lb/ft]	[kg/m <sup>2</sup> ]	[lb/ft <sup>2</sup> ]		[°C]	[°F]	FDA <sup>2)</sup>	EU <sup>3)</sup>
PE	WT	PE	WT	13	891	7.8	1.6	-0.5	-70/65	-94/149	●	●
PE	LB	PE	LB	13	891	7.8	1.6	-0.5	-70/65	-94/149	●	●
POM	WT	PBT	UC	30	2056	10.8	2.21	-0.5	-45/90	-49/194	●	●
POM	LB	PBT	LB	30	2056	10.8	2.21	-0.5	-45/90	-49/194	●	●
PP	WT	PP	WT	18	1233	6.7	1.37	0.0	5/100	41/212	●	●
PP	LB	PP	LB	18	1233	6.7	1.37	0.0	5/100	41/212	●	●

Mold to width available in: 100 mm (3.94 in), 200 mm (7.87 in), 400 mm (15.75 in)

■ LB (Light blue), □ UC (Uncolored), □ WT (White)

All measurements and tolerances apply at 21 °C; for temperature deviations please see Prolink manual chapter 4.4 "Temperature influence".

All imperial dimensions (inches) are rounded off.

<sup>1)</sup> Flex radii: r1 = side flex, r2 = front flex on roller, r3 = back flex on load bearing roller, r4 = back flex on Hold Down shoe, r5 = back flex on roller

<sup>2)</sup> Complies with FDA 21 CFR

<sup>3)</sup> Complies with (EU) 10/2011 and (EC) 1935/2004 regulations regarding the raw materials used and the migration thresholds

<sup>4)</sup> More materials and colors on request



MOVEMENT SYSTEMS



# SERIES 6.1 | BELT TYPES

siegling prolink  
modular belts

Straight running belt | Pitch 50 mm (1.97 in)

## S6.1-23 FLT | 23% Opening | Flat top

Open area (23%) for excellent air circulation and drainage | 71% contact area (Largest opening: 4.3 x 9.3 mm/0.17 x 0.37 in)  
Smooth surface | Easy-to-clean

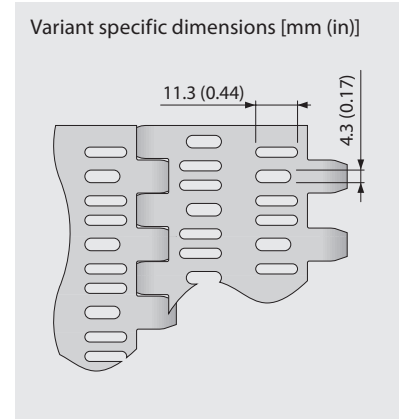
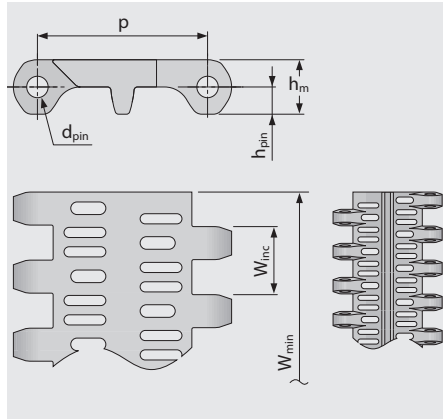
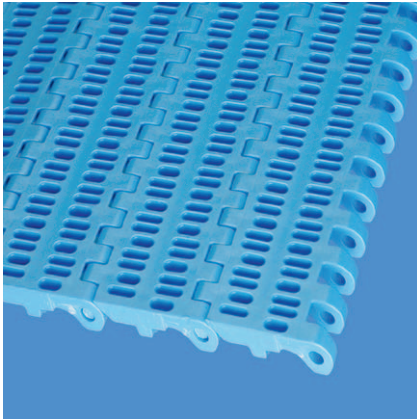

### Belt dimensions

	p	d <sub>pin</sub>	h <sub>m</sub>	h <sub>pin</sub>	h <sub>s</sub>	W <sub>min</sub>	W <sub>inc</sub>	W <sub>tol</sub>	Minimum flex radii <sup>1)</sup>				
	Pitch	Pin Ø	Thickness [mm]	Pin position [mm]	Height [mm]	Width min. [mm]	Width Increment [mm]	Width tolerance [%]	r1	r2	r3	r4	r5
mm	50.0	6.0	16.0	8.0	0.0	40.0	20.0	±0.2	-	50.0	100.0	150.0	50.0
inch	1.97	0.24	0.63	0.31	0.0	1.57	0.79	±0.2	-	1.97	3.94	5.91	1.97

### Available standard materials<sup>4)</sup>

Belt		Pin		Nominal belt pull, straight		Weight		Width deviation	Temperature		Certificates	
Material	Color	Material	Color	[N/mm]	[lb/ft]	[kg/m <sup>2</sup> ]	[lb/ft <sup>2</sup> ]	[%]	[°C]	[°F]	FDA <sup>2)</sup>	EU <sup>3)</sup>
PE	WT	PE	WT	13	891	8.2	1.68	-0.5	-70/65	-94/149	●	●
PE	LB	PE	LB	13	891	8.2	1.68	-0.5	-70/65	-94/149	●	●
POM	WT	PBT	UC	30	2056	11.3	2.31	-0.5	-45/90	-49/194	●	●
POM	LB	PBT	LB	30	2056	11.3	2.31	-0.5	-45/90	-49/194	●	●
PP	WT	PP	WT	18	1233	7.0	1.43	0.0	5/100	41/212	●	●
PP	LB	PP	LB	18	1233	7.0	1.43	0.0	5/100	41/212	●	●

Mold to order belts												
PE-MD	BL	POM-MD	BL	13	891	8.9	1.82	-0.5	-70/65	-94/149	●	●
POM-CR		PBT		30	2056	11.3	2.31	-0.5	-45/90	-49/194	-	-
PE-I	UC	PE	WT	13	891	8.2	1.68	-0.5	-70/65	-94/149	●	●

Mold to width available in: 100 mm (3.94 in), 200 mm (7.87 in), 400 mm (15.75 in)

■ BL (Blue), ■ LB (Light blue), □ UC (Uncolored), □ WT (White)

All measurements and tolerances apply at 21 °C; for temperature deviations please see ProLink manual chapter 4.4 "Temperature influence".

All imperial dimensions (inches) are rounded off.

<sup>1)</sup> Flex radii: r1 = side flex, r2 = front flex on roller, r3 = back flex on load bearing roller, r4 = back flex on Hold Down shoe, r5 = back flex on roller

<sup>2)</sup> Complies with FDA 21 CFR

<sup>3)</sup> Complies with (EU) 10/2011 and (EC) 1935/2004 regulations regarding the raw materials used and the migration thresholds

<sup>4)</sup> More materials and colors on request



MOVEMENT SYSTEMS

# SERIES 6.1 | BELT TYPES

siegling prolink  
modular belts

Straight running belt | Pitch 50 mm (1.97 in)

## S6.1-36 FLT | 36% Opening | Flat top

Open area (36%) for excellent air circulation and drainage | 35% contact area (Largest opening: 11.8 x 15.2 mm/0.46 x 0.6 in)  
Smooth surface | Easy-to-clean

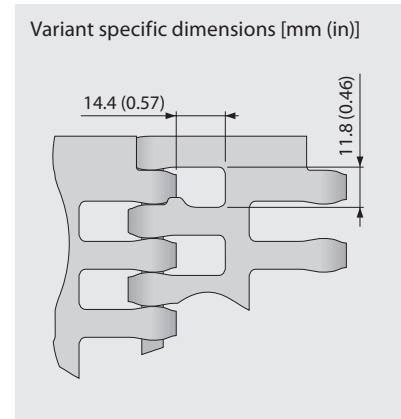
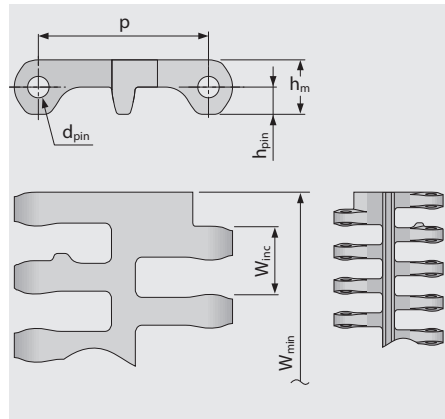
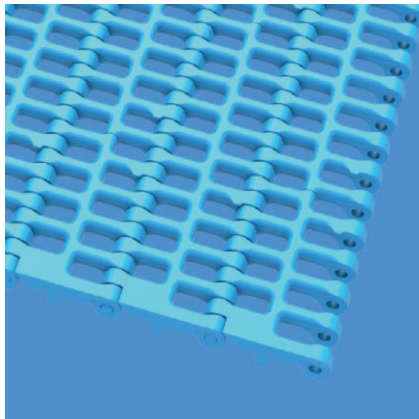

### Belt dimensions

	p	d <sub>pin</sub>	h <sub>m</sub>	h <sub>pin</sub>	h <sub>s</sub>	W <sub>min</sub>	W <sub>inc</sub>	W <sub>tol</sub>	Minimum flex radii <sup>1)</sup>				
	Pitch	Pin Ø	Thickness [mm]	Pin position [mm]	Height [mm]	Width min. [mm]	Width Increment [mm]	Width tolerance [%]	r1	r2	r3	r4	r5
mm	50.0	6.0	16.0	8.0	0.0	40.0	20.0	±0.2	-	50.0	100.0	150.0	50.0
inch	1.97	0.24	0.63	0.31	0.0	1.57	0.79	±0.2	-	1.97	3.94	5.91	1.97

### Available standard materials<sup>4)</sup>

Belt		Pin		Nominal belt pull, straight		Weight		Width deviation	Temperature		Certificates	
Material	Color	Material	Color	[N/mm]	[lb/ft]	[kg/m <sup>2</sup> ]	[lb/ft <sup>2</sup> ]	[%]	[°C]	[°F]	FDA <sup>2)</sup>	EU <sup>3)</sup>
PE	WT	PE	WT	13	891	6.2	1.27	-0.5	-70/65	-94/149	●	●
PE	LB	PE	LB	13	891	6.2	1.27	-0.5	-70/65	-94/149	●	●
POM	WT	PBT	UC	30	2056	9.0	1.84	-0.5	-45/90	-49/194	●	●
POM	LB	PBT	LB	30	2056	9.0	1.84	-0.5	-45/90	-49/194	●	●
PP	WT	PP	WT	18	1233	5.9	1.21	0.0	5/100	41/212	●	●
PP	LB	PP	LB	18	1233	5.9	1.21	0.0	5/100	41/212	●	●

Mold to order belts												
PP-MD	BL	PP-MD	BL	18	1233	6.4	1.31	0.0	5/100	41/212	●	●
PE-MD	BL	POM-MD	BL	13	891	6.7	1.37	-0.5	-70/65	-94/149	●	●
POM-MD	BL	POM-MD	BL	30	2056	9.2	1.88	-0.5	-45/90	-49/194	●	●

**Attention!** Due to the very large surface openings, personnel must be instructed not to place their fingers in or on this belt.

■ BL (Blue), ■ LB (Light blue), □ UC (Uncolored), □ WT (White)

All measurements and tolerances apply at 21 °C; for temperature deviations please see Prolink manual chapter 4.4 "Temperature influence".

All imperial dimensions (inches) are rounded off.

<sup>1)</sup> Flex radii: r1 = side flex, r2 = front flex on roller, r3 = back flex on load bearing roller, r4 = back flex on Hold Down shoe, r5 = back flex on roller

<sup>2)</sup> Complies with FDA 21 CFR

<sup>3)</sup> Complies with (EU) 10/2011 and (EC) 1935/2004 regulations regarding the raw materials used and the migration thresholds

<sup>4)</sup> More materials and colors on request



MOVEMENT SYSTEMS



# SERIES 6.1 | SPROCKETS

siegling prolink  
modular belts

Straight running belt | Pitch 50 mm (1.97 in)

## S6.1 SPR | Sprockets

Special easy-to-clean sprocket with enhanced tooth engagement for excellent force transmission

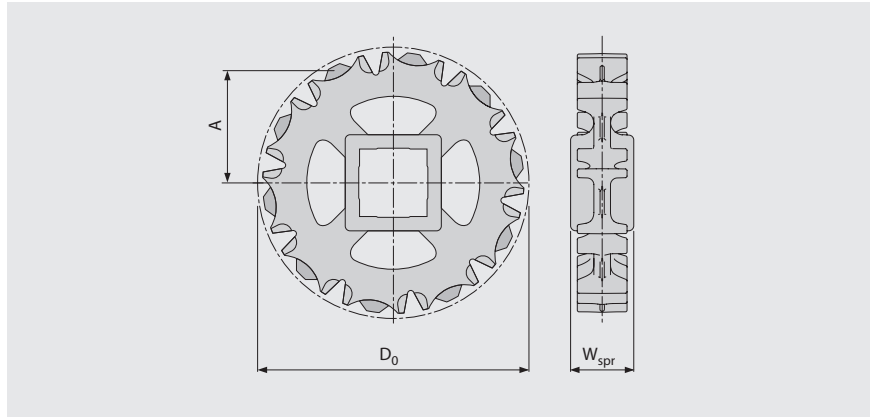

### Main dimensions

Sprocket size (Number of teeth)		Z6	Z8	Z10	Z12	Z16
W <sub>spr</sub>	mm	40.0	40.0	40.0	40.0	40.0
	inch	1.57	1.57	1.57	1.57	1.57
D <sub>0</sub>	mm	101.6	132.9	163.5	195.3	257.8
	inch	4.00	5.23	6.44	7.69	10.15
A <sub>max</sub>	mm	41.6	57.8	73.3	89.3	120.7
	inch	1.64	2.28	2.89	3.52	4.75
A <sub>min</sub>	mm	36.0	53.4	69.7	86.3	118.4
	inch	1.42	2.10	2.74	3.40	4.66

### Shaft bores (● = Round, ■ = Square)

30	mm	●	●	●		
40	mm	■	■	■	■	■
60	mm			■	■	■
1	inch	●	●	●		
1.25	inch		●	●		
1.44	inch			●		
1.5	inch	■	■	■	●/■	■
2	inch			■		■
2.5	inch			■	■	■

Material: PA, Color: LG

■ LG (Light gray)

All measurements and tolerances apply at 21 °C; for temperature deviations please see Prolink manual chapter 4.4 "Temperature influence".

All imperial dimensions (inches) are rounded off.

For detailed sprocket and shaft dimensions see appendix 6.3.



MOVEMENT SYSTEMS

# SERIES 6.1 | PROFILES

siegling prolink  
modular belts

Straight running belt | Pitch 50 mm (1.97 in)

## S6.1-0 FLT PMU/S6.1-0 FLT PMU I40

Flat top surface for dry products

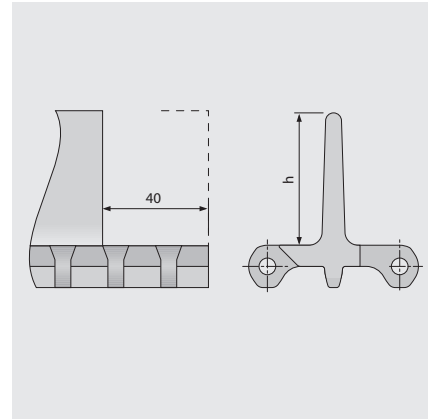

### Basic data

Material	Color	Height (h)		
		50 mm 2 inch	100 mm 4 inch	150 mm 6 inch
PE	LB/WT	●/▲	●/▲	●
POM-CR	LB		●	
POM	LB/WT	●/▲	●/▲	●
POM-MD	BL	●	●	●
PP	LB/WT	●/▲	●/▲	●
PP-MD	BL		●	

● = no indent, ▲ = with indent 40 mm

Molded width: 200 mm (7.9 in)

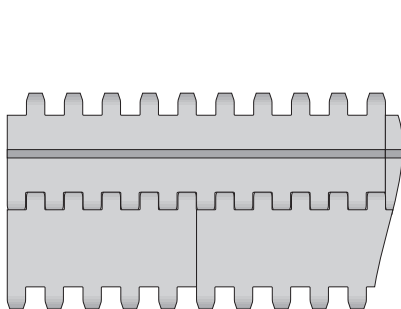

Standard configuration S6.1-0 FLT PMU

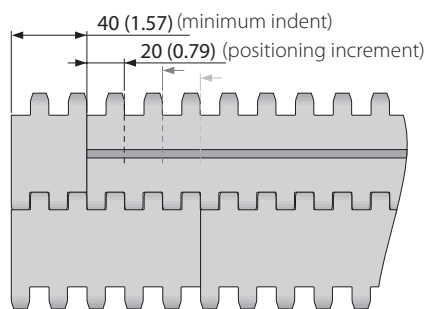

Indent configuration S6.1-0 FLT PMU

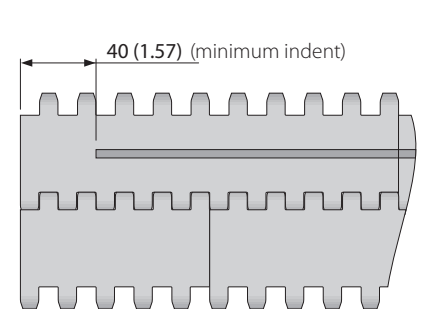

Standard configuration S6.1-0 FLT PMU I40

■ BL (Blue), ■ LB (Light blue), □ WT (White)

All measurements and tolerances apply at 21 °C; for temperature deviations please see Prolink manual chapter 4.4 "Temperature influence".

All imperial dimensions (inches) are rounded off.

Note: Use of accessory in a belt may impact on the minimum design radii. Please see chapter 6.3 for further information.



MOVEMENT SYSTEMS

# SERIES 6.1 | PROFILES

siegling prolink  
modular belts

Straight running belt | Pitch 50 mm (1.97 in)

## S6.1-0 NCL PMU

No cling surface with nub top base to improve release of wet and sticky products

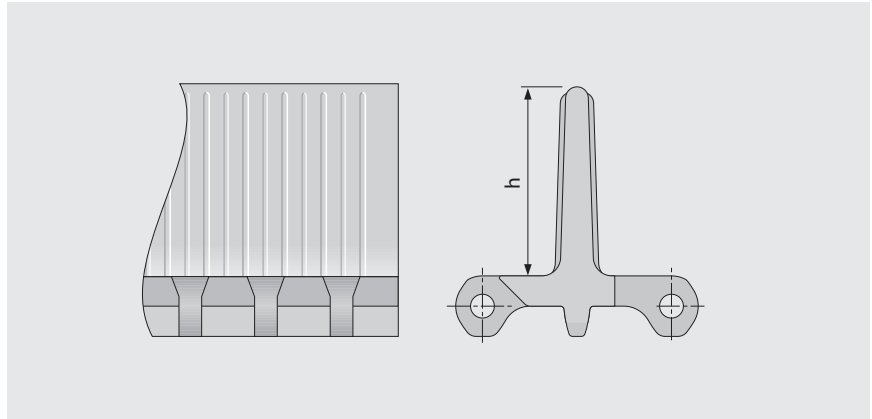

### Basic data

Material	Color	Height (h)
		100 mm 4 inch
PE	LB	●
PE	WT	●

Molded width: 200 mm (7.9 in)

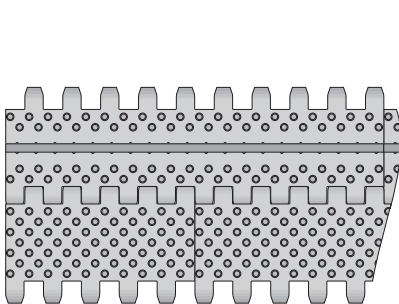

Standard configuration S6.1-0 NCL PMU

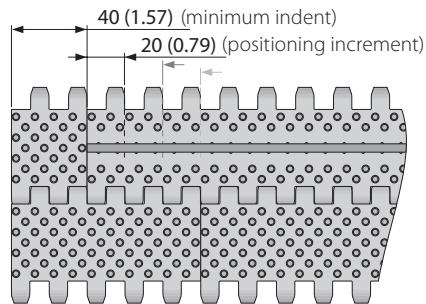

Indent configuration S6.1-0 NCL PMU

■ LB (Light blue), □ WT (White)

All measurements and tolerances apply at 21 °C; for temperature deviations please see Prolink manual chapter 4.4 "Temperature influence".

All imperial dimensions (inches) are rounded off.

Note: Use of accessory in a belt may impact on the minimum design radii. Please see chapter 6.3 for further information.



MOVEMENT SYSTEMS

# SERIES 6.1 | PROFILES

siegling prolink  
modular belts

Straight running belt | Pitch 50 mm (1.97 in)

## S6.1-23 NCL PMU

No cling surface with open area base (23%) to improve release of wet and sticky products

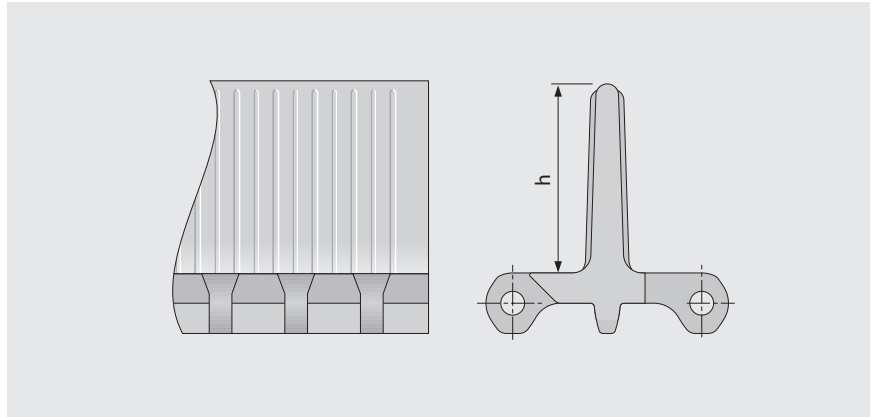

### Basic data

Material	Color	Height (h)
		100 mm 4 inch
PE	LB	●
PE	WT	●
PP	LB	●
PP	WT	●

Molded width: 200 mm (7.9 in)

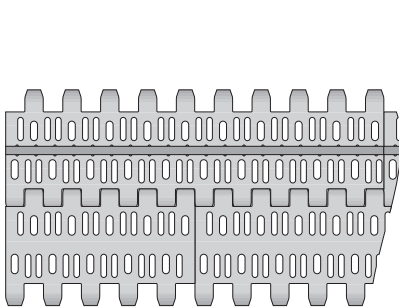

Standard configuration S6.1-23 NCL PMU

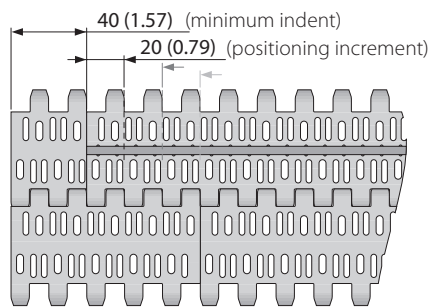

Indent configuration S6.1-23 NCL PMU

■ LB (Light blue), □ WT (White)

All measurements and tolerances apply at 21 °C; for temperature deviations please see ProLink manual chapter 4.4 "Temperature influence".

All imperial dimensions (inches) are rounded off.

Note: Use of accessory in a belt may impact on the minimum design radii. Please see chapter 6.3 for further information.



MOVEMENT SYSTEMS

# SERIES 6.1 | PROFILES

siegling prolink  
modular belts

Straight running belt | Pitch 50 mm (1.97 in)

## S6.1-0 FLT PSU-0

Scooped profiles with a closed, flat top surface for steep incline conveyors

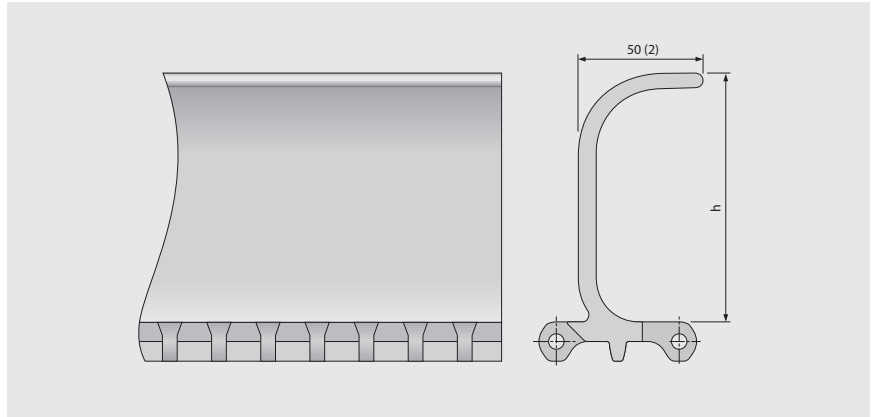
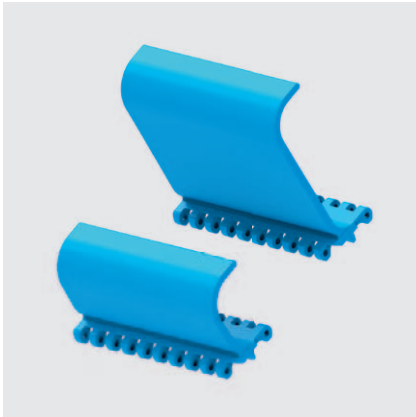

### Basic data

Material	Color	Height (h)		
		76 mm 3 inch	102 mm 4 inch	152 mm 6 inch
PE	LB	●	●	●
PE	WT	●	●	●
POM	LB	●	●	●
POM	WT	●	●	●
PP	LB	●	●	●
PP	WT	●	●	●
PP-MD	BL		●	●

Molded width: 200 mm (7.9 in)

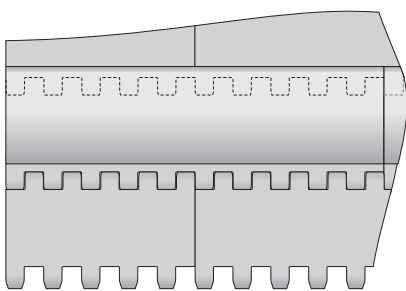

Standard configuration S6.1-0 FLT PSU-0

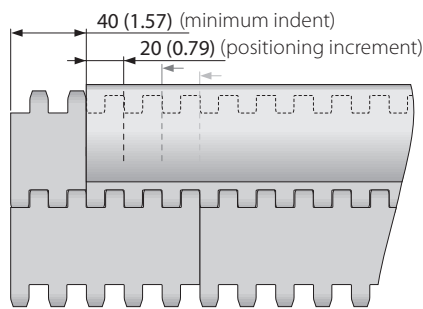

Indent configuration S6.1-0 FLT PSU-0

■ BL (Blue), ■ LB (Light blue), □ WT (White)

All measurements and tolerances apply at 21 °C; for temperature deviations please see ProLink manual chapter 4.4 "Temperature influence".

All imperial dimensions (inches) are rounded off.

Note: Use of accessory in a belt may impact on the minimum design radii. Please see chapter 6.3 for further information.



MOVEMENT SYSTEMS

# SERIES 6.1 | PROFILES

siegling prolink  
modular belts

Straight running belt | Pitch 50 mm (1.97 in)

## S6.1-0 FLT PSU-16

Scooped profiles with 16 % open area and a flat top surface allowing product drainage when conveying up steep inclines

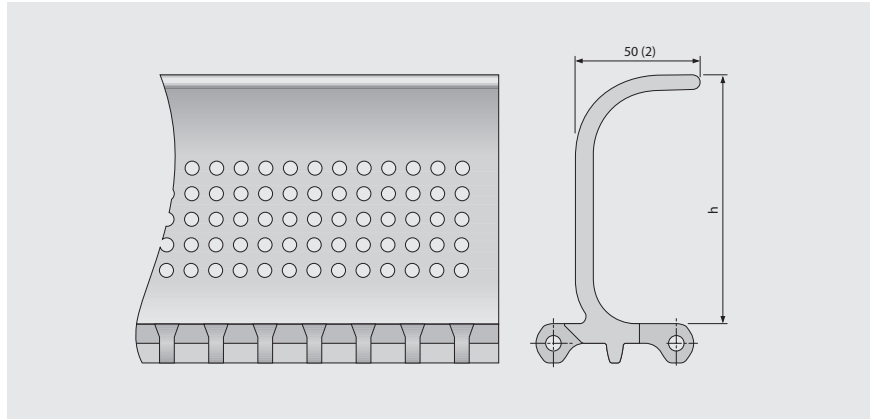

### Basic data

Material	Color	Height (h)	
		102 mm 4 inch	152 mm 6 inch
PE	LB	●	●
PE	WT	●	●
POM	LB	●	●
POM	WT	●	●
PP	LB	●	●
PP	WT	●	●

Molded width: 200 mm (7.9 in)

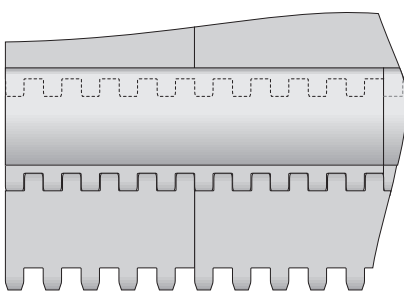

Standard configuration S6.1-0 FLT PSU-16

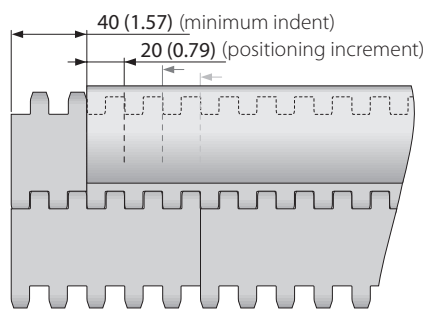

Indent configuration S6.1-0 FLT PSU-16

■ LB (Light blue), □ WT (White)

All measurements and tolerances apply at 21 °C; for temperature deviations please see Prolink manual chapter 4.4 "Temperature influence".

All imperial dimensions (inches) are rounded off.

Note: Use of accessory in a belt may impact on the minimum design radii. Please see chapter 6.3 for further information.



MOVEMENT SYSTEMS



# SERIES 6.1 | PROFILES

siegling prolink  
modular belts

Straight running belt | Pitch 50 mm (1.97 in)

## S6.1-0 FLT BPU

Bucket Profiles for contained conveying of bulk products up steep inclines

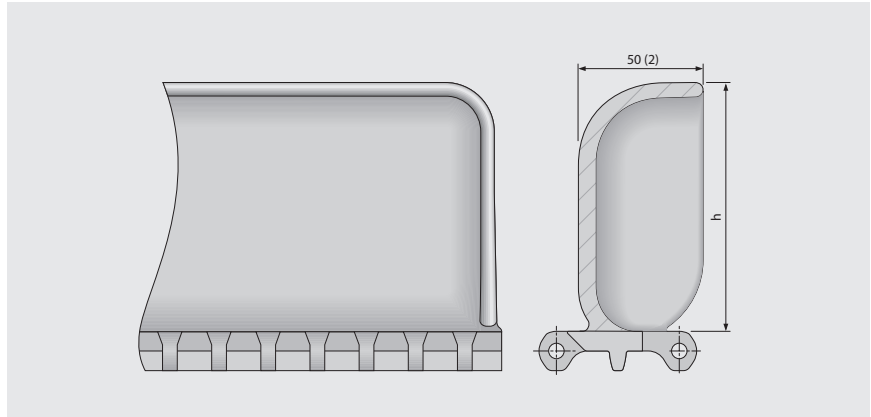

### Basic data

Material	Color	Height (h)	
		102 mm 4 inch	152 mm 6 inch
PE	LB	●	●
PE	WT	●	●
POM	LB	●	●
POM	WT	●	●
PP	LB	●	●
PP	WT	●	●

Molded width: 200 mm (7.9 in)

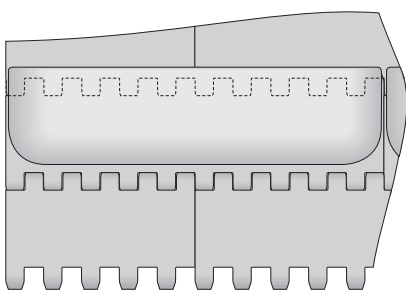

Standard configuration S6.1-0 FLT BPU

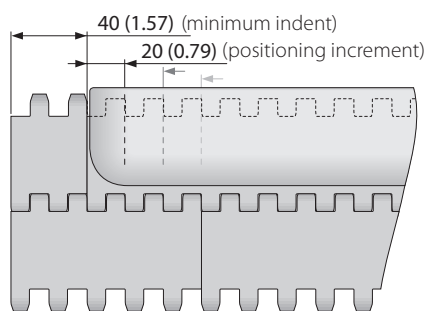

Indent configuration S6.1-0 FLT BPU

■ LB (Light blue), □ WT (White)

All measurements and tolerances apply at 21 °C; for temperature deviations please see Prolink manual chapter 4.4 "Temperature influence".

All imperial dimensions (inches) are rounded off.

Note: Use of accessory in a belt may impact on the minimum design radii. Please see chapter 6.3 for further information.



MOVEMENT SYSTEMS

# SERIES 6.1 | SIDE GUARDS

siegling prolink  
modular belts

Straight running belt | Pitch 50 mm (1.97 in)

## S6.1 SG | Side guards

For retention of bulk products

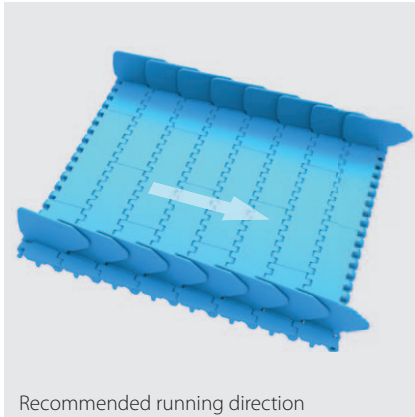

Recommended running direction

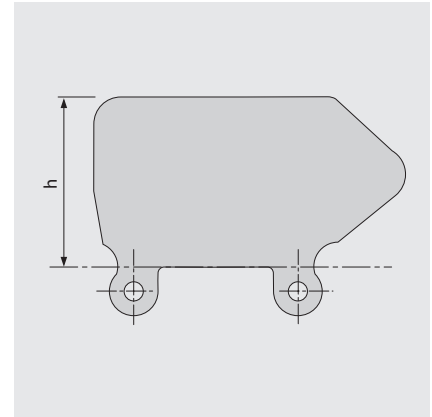

### Basic data

Material	Color	Height (h)			
		25 mm 1 inch	50 mm 2 inch	75 mm 3 inch	100 mm 4 inch
PE	LB	●	●	●	●
PE	WT	●	●	●	●
PE-MD	BL		●	●	●
PP	LB	●	●	●	●
PP	WT	●	●	●	●

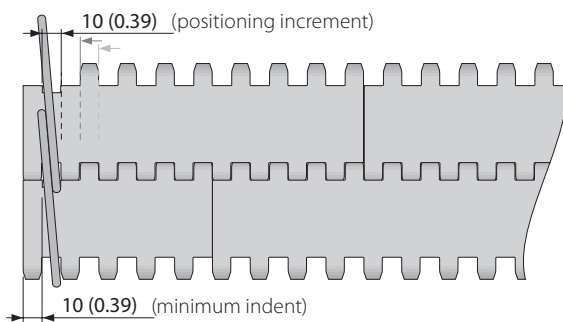

■ BL (Blue), ■ LB (Light blue), □ WT (White)

All measurements and tolerances apply at 21 °C; for temperature deviations please see Prolink manual chapter 4.4 "Temperature influence".

All imperial dimensions (inches) are rounded off.

Note: Use of accessory in a belt may impact on the minimum design radii. Please see chapter 6.3 for further information.



MOVEMENT SYSTEMS

# SERIES 6.1 | HOLD DOWN TABS

siegling prolink  
modular belts

Straight running belt | Pitch 50 mm (1.97 in)

## S6.1 HDT | Hold Down Tabs

Used on wider belts to prevent lift an swan neck conveyors | To improve strength, stability and cleanliness they are moulded on a narrow module

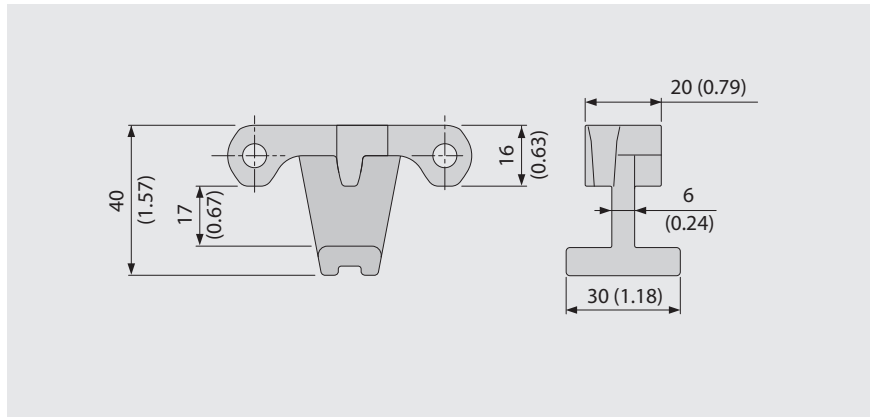

### Basic data

Material	Color
POM	LB
	WT

### Example

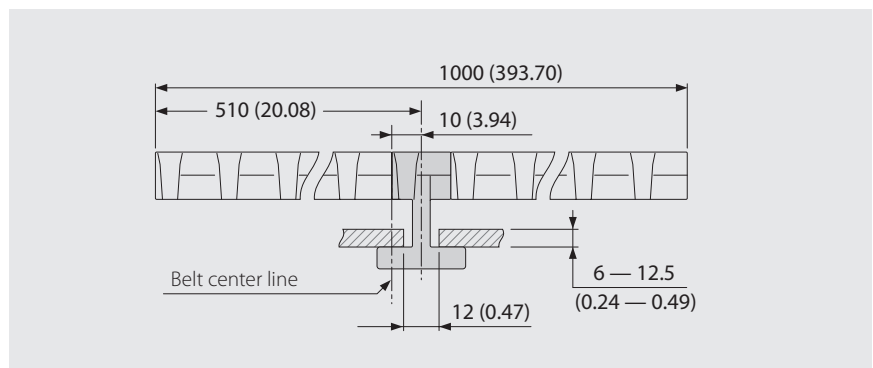

Using Hold Down Tabs results in constraints with regards to sprocket and shaft size to ensure sufficient clearance to the shaft.

### Sprocket options using HDT

Sprocket size (Number of teeth)	Maximum bore round		Maximum bore square	
	[mm]	[inch]	[mm]	[inch]
Z6	20	0.75	15	0.5
Z8	50	1.75	40	1.5
Z10	80	3.0	60	2.5
Z12	110	4.25	85	3.25
Z16	170	6.5	130	5.25

■ LB (Light blue), □ WT (White)

All measurements and tolerances apply at 21 °C; for temperature deviations please see Prolink manual chapter 4.4 "Temperature influence".

All imperial dimensions (inches) are rounded off.

Note: Use of accessory in a belt may impact on the minimum design radii. Please see chapter 6.3 for further information.



MOVEMENT SYSTEMS

# SERIES 6.1 | PRR

siegling prolink  
modular belts

Straight running belt | Pitch 50 mm (1.97 in)

## S6.1 PRR | Pin Retained Rollers

For applications where low back pressure accumulation or product separation is required

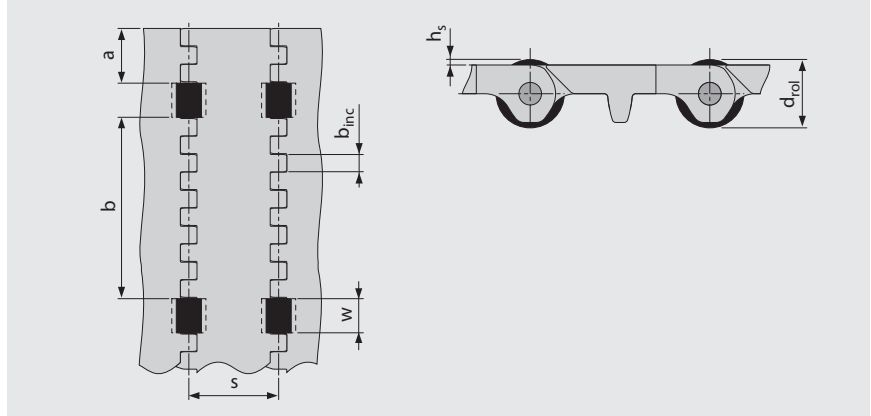
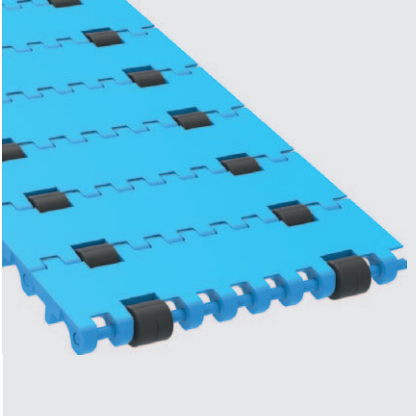

- For low back pressure wearstrips are to be positioned between the rollers
- For product separation the wearstrips are to be positioned below the rollers
- For all materials and surfaces
- Rollers available in POM BK

### Dimensions

w	20 (0.79)	Roller cut out width (roller width 19 mm (0.75 in))
h <sub>s</sub>	2 (0.08)	Height of rollers above surface
d <sub>rol</sub>	20 (0.79)	Roller diameter
a	30 (1.2)	Minimum indent
b	100 (3.9)	Standard distance between rollers across belt width
b <sub>inc</sub>	10 (0.39)	Roller distance increment
s	50 (2.0)	Standard roller spacing in travel direction (every pitch)
n <sub>rol</sub>	Number of rollers across belt width	
W <sub>B</sub>	Belt width	

### Allowable belt pull

To determine admissible belt pull calculate effective belt width  $W_{B,ef}$  by

$$W_{B,ef} = W_B - (w \times n_{rol})$$

Example:  $W_B = 200 \text{ mm (7.87 in)}$ ;  $A = 20 \text{ mm (0.79 in)}$ ;  $l = 2$

$$W_{B,ef} = 200 - (2 \times 20) = 160 \text{ mm}$$

$$W_{B,ef} = 7.87 - (2 \times 0.79) = 6.29 \text{ in}$$

Note sprocket must not be placed inline with rollers.

Coefficient of friction between belt and conveyed product in accumulation mode  $\mu_{acc} = 0.04$ , i.e. the accumulation pressure is approx. 4% of the weight of the backed up product.

All measurements and tolerances apply at 21 °C; for temperature deviations please see Prolink manual chapter 4.4 "Temperature influence".

All imperial dimensions (inches) are rounded off.

Note: Use of accessory in a belt may impact on the minimum design radii. Please see chapter 6.3 for further information.



MOVEMENT SYSTEMS

# LEGEND

## ① Series

S1 ... S15

## ② Open area/Sprocket size

Percentage open area

Format: xx

E.g. 20 = 20%

For sprockets: number of teeth

Format: "Z"xx

E.g. Z12 = 12 teeth

## ③ Surface pattern

**BSL** Base module for slider

**CTP** Cone top

**CUT** Curved top

**FLT** Flat top (smooth)

**FRT-OG** Friction top without High Grip insert

**FRT(X)** Friction top (Design X)

**GRT** Grid top

**LRB** Lateral rib

**MOD** Modified module shape

**NCL** No cling

**NPY** Negative pyramid

**NSK** Non skid

**NTP** Nub top (round studs)

**RAT** Radius top

**RRB** Raised rib

**RSA** Reduced surface area

**RTP** Roller top

**SRS** Slip-resistant surface

## ④ Type

**A90** Angle 90° to conveying direction

**BPU** Bucket profile

**CCW** Counter clockwise

**CLP** Clip

**CM** Center module

**CW** Clockwise

**FPL** Finger plate

**IDL** Idler

**PIN** Coupling rod

**PMC** Profile module center

**PMU** Profile module universal

**PMU lxx** Profile module universal with indent xx = indent in mm

**RI** High Grip insert

**RTR** Retaining ring

**SG** Module with sideguard

**SLI** Slider

**SML** Side module, left

**SMR** Side module, right

**SMU** Side module, universal/both sides

**SPR** Sprocket

**TPL** Turning panel, left

**TPR** Turning panel, right

**UM** Universal module

## ⑤ Style

**BT** Bearing tab

**DR** Double row sprocket

**F1, F2, F3 ...** Collapse factor modules

**G** Guided

**GT** Guiding tabs

**HD** Hold Down

**RG** Reversed guided

**SG** Side guard

**SP** Split sprocket

**ST** Strong

## ⑥ Material

**PA** Polyamide

**PA-HT** Polyamide high temperature

**PBT** Polybutylentere-phthalate

**PE** Polyethylene

**PE-MD** PE metal detectable

**POM** Polyoxymethylene (Polyacetal)

**POM-CR** POM cut resistant

**POM-HC** POM highly conductive

**POM-MD** POM metal detectable

**POM-PE** POM side modules + PE center modules

**POM-PP** POM side modules + PP center modules

**PP** Polypropylene

**PXX-HC** Self-extinguishing highly conductive material

**R1** TPE 80 Shore A, PP

**R2** EPDM 80 Shore A, vulcanized

**R3** TPE 70 Shore A, POM

**R4** TPE 86 Shore A, PP

**R5** TPE 52 Shore A, PP

**R6** TPE 63 Shore A, POM

**R7** TPE 50 Shore A, PP

**R8** TPE 55 Shore A, PE

**SER** Self-extinguishing TPE

**SS** Stainless steel

**TPC1** Thermoplastic Copolyester

**-HA** Supports the HACCP concept

**-HW** High Wear resistant material

## ⑦ Color\*

**AT** Anthracite

**BG** Beige

**BK** Black

**BL** Blue

**DB** Dark blue

**GN** Green

**LB** Light blue

**LG** Light gray

**OR** Orange

**RE** Red

**TQ** Turquoise

**TR** Transparent

**UC** Uncolored

**WT** White

**YL** Yellow

## ⑧ Height/Diameter/ Bore size and style

Height in mm (in)

Format: Hxxx

Pin diameter in mm (in)

Format: Dxxx

Bore size: SQ (= square)

or RD (= round)

either in mm or inches

Format: SQxxMM or RDxxIN

## ⑨ Length/Width

Pins Length in mm (in)

Format: Lxxx

Module width in mm (in)

Format: Wxxx

\* For each series' standard colors please refer to the table of materials for each belt (chapter 1.2). A number of other colors are available on request. Colors can vary from the original due to the print, production processes or material used.