











Prese ad Innesto Rapido - Quick Couplings - Schnellverschluss Kupplungen
 Coupleurs Automatiques - Enchufes Rápidos - Conexões de Engate Rápido

<p>SERIE UNI ISO 6150 A-6</p>  <p>Serie 100 Pag. 15.7 - 15.10</p>	<p>SERIE MIGNON</p>  <p>Serie 110 Pag. 15.11 - 15.16</p>	<p>SERIE UNI ISO 6150 B-12</p>  <p>Serie 120 Pag. 15.17 - 15.22</p>	<p>ITALIAN PROFILE</p>  <p>Serie 120 Pag. 15.23 - 15.28</p>	<p>SERIE UNI ISO 6150 B-15</p>  <p>Serie 130 Pag. 15.29 - 15.33</p>
<p>SERIE UNI ISO 6150 C-10</p>  <p>Serie 140 Pag. 15.34 - 15.39</p>	<p>EUROPEAN PROFILE</p>  <p>Serie 160 Pag. 15.40 - 15.45</p>	<p>SWISS PROFILE</p>  <p>Serie 170 Pag. 15.46 - 15.50</p>	<p>MIGNON PROFILE</p>  <p>Serie 180 Pag. 15.51 - 15.54</p>	<p>MULTISOCKET</p>  <p>Serie 190 - 63190 Pag. 15.55 - 15.61</p>
<p>JAPANESE PROFILE</p>  <p>Serie 400 Pag. 15.62 - 15.64</p>	<p>MINI DN 2,7</p>  <p>Serie 700 Pag. 15.65 - 15.67</p>	<p>SERIE UNI ISO 6150 B-17</p>  <p>Serie 710 Pag. 15.68 - 15.70</p>	<p>B-SOCKET EUROPEAN</p>  <p>Serie 720 Pag. 15.71 - 15.74</p>	<p>EUROPEAN PROFILE New</p>  <p>Serie 730 Pag. 15.75 - 15.80</p>
<p>EUROPEAN PROFILE New</p>  <p>Serie 740 Pag. 15.81 - 15.83</p>				

Prese di Sicurezza ad Innesto Rapido - Safety Quick Couplings - Kupplungen Sicherheit - Coupleurs de Sécurité
 Enchufes de Seguridad - Conexões de Segurança

<p>SERIE UNI ISO 6150 B-12</p>  <p>Serie 620 Pag. 15.87 - 15.88</p>	<p>ITALIAN PROFILE</p>  <p>Serie 650 Pag. 15.89 - 15.90</p>	<p>EUROPEAN PROFILE</p>  <p>Serie 660 Pag. 15.91 - 15.92</p>	<p>SWISS PROFILE</p>  <p>Serie 670 Pag. 15.93 - 15.94</p>	<p>SERIE UNI ISO 6150 B-12 New</p>  <p>Serie 0B120 Pag. 15.97 - 15.99</p>
<p>SERIE UNI ISO 6150 C-10 New</p>  <p>Serie 0B140 Pag. 15.100 - 15.102</p>				

Giunti ad Innesto Rapido per Raffreddamento Stampi - Quick Couplings for Molding Cooling - Schnellkupplungen für Spritzgussanwendungen
 Coupleurs pour Moules D'injection - Enchufes Rápidos para Refrigeración de Moldes - Conexões de Engate Rápido para Resfriamento de Moldes

<p>FRENCH PROFILE DN 8 - DN 12</p>  <p>Series 410-420 - 510 - 520 Pag. 15.104 - 15.110</p>	<p>INTERNATIONAL PROFILE DN 6 - DN 9</p>  <p>Series 430-440 - 530 - 540 Pag. 15.112 - 15.119</p>	<p>EUROPEAN PROFILE DN 6 - DN 9</p>  <p>Series 460-470 - 560 - 570 Pag. 15.120 - 15.127</p>
--	--	---

Pistole di Soffiaggio - Blow Guns - Blaspistolen - Soufflantes - Pistolas Sopladoras - Pistola de Ar

 <p>Series 360 Pag. 15.129 - 15.130</p>	 <p>Series 300 Pag. 15.131 - 15.133</p>	 <p>Spare Parts Pag. 15.134</p>	 <p>Series 340 Pag. 15.135 - 15.136</p>
---	---	---	--

GIUNTI AD INNESTO RAPIDO E PISTOLE AD ARIA

AUTOMATIC QUICK COUPLINGS AND BLOW GUNS

SCHNELLVERSCHLUSS-KUPPLUNGEN UND BLASPISTOLEN

COUPLEURS AUTOMATIQUES ET SOUFFLETTES

ENCHUFES RÁPIDOS Y PISTOLAS DE AIRE

CONEXÕES DE ENGATE RÁPIDO E PISTOLAS DE AR



Serie Quick Couplings

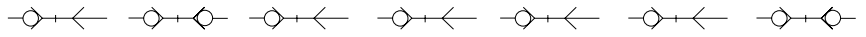

PLUG PROFILE 1:1	STANDARD	SINGLE SHUT OFF	DOUBLE SHUT OFF	STANDARD	MULTI	SAFETY	INOX	DOUBLE SHUT OFF	
	DN 5 MIGNON	210 Pag. 15.11	280 Pag. 15.51	110 Pag. 15.11				180 Pag. 15.51	
	DN 2.5 UNI-ISO 6150-A6	200 Pag. 15.7		100 Pag. 15.7					
	DN 5.5 UNI-ISO 6150-B12 INDUSTRIAL 1/4	220 Pag. 15.17		120 Pag. 15.17	190 Pag. 15.55	620 Pag. 15.87 OB120 Pag. 15.97			
	DN 9 UNI-ISO 6150-B15 INDUSTRIAL 3/8	230 Pag. 15.29		130 Pag. 15.29	720 Pag. 15.71				
	DN 12 UNI-ISO 6150-B17 INDUSTRIAL 1/2	810 Pag. 15.68		710 Pag. 15.68					
	DN 5.5 UNI-ISO 6150-C10	240 Pag. 15.34		140 Pag. 15.34		OB140 Pag. 15.100			
	DN 7.5 - 7.8 EUROPEAN	260 Pag. 15.40	63260 Pag. 15.59	840 Pag. 15.81	160 Pag. 15.40 730 Pag. 15.75	190 Pag. 15.55	660 Pag. 15.91	63190 Pag. 15.59	740 Pag. 15.81
	DN 10 EUROPEAN DN 10	820 Pag. 15.71		720 Pag. 15.71					
	DN 5.5 SWISS	270 Pag. 15.46		170 Pag. 15.46	190 Pag. 15.55	670 Pag. 15.93			
	DN 7.5 JAPANESE	500 Pag. 15.62		400 Pag. 15.62					
	DN 5 ITALIAN	250 Pag. 15.23		120 Pag. 15.23	190 Pag. 15.55	650 Pag. 15.89			
	DN 2.7 MINI	800 Pag. 15.65		700 Pag. 15.65					
	DN 8 FRENCH	510 Pag. 15.106		410 Pag. 15.106					
	DN 12 FRENCH	520 Pag. 15.109		420 Pag. 15.109					
	DN 6 INTERNATIONAL	530 Pag. 15.114		430 Pag. 15.114					
	DN 9 INTERNATIONAL	540 Pag. 15.117		440 Pag. 15.117					
	DN 6 EUROPEAN	560 Pag. 15.122		460 Pag. 15.122					
	DN 9 EUROPEAN	570 Pag. 15.125		470 Pag. 15.125					

RECTUS/PARKER 21/90	CAMOZZI 5050 - 5150	CEJN 200		FESTO KD - KS 2	
RECTUS/LEGRIS 23/24 PARKER 20/30 - 1/4 TEMA 1400	HANSEN 3000	CEJN 310	INDUSTRIAL 1/4	GROMELLE 600	US - MIL SPEC C-4109
RECTUS/LEGRIS 30 PARKER 30 - 3/8	HANSEN 4000	CEJN 430	INDUSTRIAL 3/8	GROMELLE 900	US - MIL SPEC C-4109
RECTUS 37	HANSEN 5000	CEJN 550		GROMELLE 1300	US - MIL SPEC C-4109
RECTUS/LEGRIS 18					
RECTUS/LEGRIS 25/26/1600/1625 TEMA 1600	CAMOZZI 5080 - 5180	CEJN 320		FESTO KD - KS 6 KD - KS 4	
RECTUS/LEGRIS 27		CEJN 410			
RECTUS/LEGRIS 14/22 PARKER 50	HANSEN 210	CEJN 300		ARO 210	
RECTUS/LEGRIS 13	SMC KK130	CEJN 315	NITTO KOHKI 200		
RECTUS/LEGRIS PARKER 20/91				FESTO KD - KS 2	
RECTUS 608					
RECTUS 612					
RECTUS 86	DME 1/4				
RECTUS 87	DME 3/8				
RECTUS 10	HASCO Z80/811HT/9 [Øe 9]	CEJN 220 - 221 - 225			
RECTUS 11	HASCO Z80/811HT/13 [Øe 13.5]				

La gamma dei giunti ad innesto rapidi Aignep permette una risposta adeguata ai molteplici bisogni dei nostri clienti. Le differenti applicazioni, le prestazioni e l'affidabilità, sono i vantaggi dati dall'insieme di questa importantissima gamma.

A semplice o doppia intercettazione in ottone nichelato, in acciaio inox, conformi alle principali norme di riferimento possono essere utilizzati per veicolare molteplici fluidi.

A completamento pistole di soffiaggio.

Principali vantaggi

- Passaggi da DN 2,5 a 12 mm
- Profili normalizzati
- Gamme Multipresa
- Montaggio con una sola mano
- Leggerezza ed ingombro ridotto
- Versioni di sicurezza
- Raffreddamento stampi normalizzati
- Silicon Free

Applicazioni

- Impianti Aria Compressa e Strumenti
- Automazione Pneumatica e Fluidica
- Food & Beverage
- Life & Sciences
- Raffreddamento stampi
- Gas inerti, versioni per vuoto

Aignep range of quick couplings is able to satisfy multiple needs of our customers.

Wide variety of models: single & double shut-off, multisocket, safety.

The most popular profiles and nominal diameters available in nickel-plated brass and stainless steel.

For compressed air and for moulding injection cooling system.

To complete the line a wide range of air blow guns.

Main advantages

- DN 2,5 - 12 mm
- Standard profiles
- Multisocket
- Single handed operation
- Light and compact
- Safety version
- Moulding couplers
- Silicon Free

Applications

- Compressed Air & Tools
- Pneumatic & Fluidtechnology
- Food & Beverage
- Life & Sciences
- Cooling System
- Inert Gases, Vacuum

Die Schnellverschlusskupplungs-Serie von Aignep antwortet auf die vielfältigen Bedürfnisse unserer Kunden. Zahlreiche verschiedene Modelle: Einzel- und Doppelabsperrung, Mehrfachstecker, Sicherheitskupplungen.

Die beliebtesten Profile und Nennweiten sind aus vernickeltem Messing und Edelstahl verfügbar.

Für Druckluft und für Spritzguss-Kühlsysteme zu formen. Zur Vervollständigung der Serie eine große Auswahl an Blaspistolen.

Hauptvorteile

- DN 2,5 – 12 mm
- Standard Profile
- Mehrfachstecker
- Einhändige Bedienung
- Leicht und kompakt
- Sicherheits Versionen
- Spritzwerkzeug-Kühlung
- Silikonfrei

Anwendungen

- Druckluft & Werkzeuge
- Pneumatik und Fluidtechnik
- Lebensmittel & Getränke
- Life Science
- Kühlsysteme
- Inertgase, Vakuum

FR

Les coupleurs rapides Aignep répondent à de nombreuses utilisations. Grande variété de modèles en version simple et double obturation, multiprise, de sécurité. Les profils et les diamètres nominaux les plus courants sont disponibles en laiton nickelé et acier inoxydable 316L.

Pour air comprimé et tous fluides industriels ainsi qu'une gamme dédiée pour le refroidissement des moules dans l'injection plastique. Une large gamme de soufflettes vient compléter notre offre.

Principaux avantages

- DN 2,5 - 12 mm
- Profils standards
- Multisocket
- Opération d'une seule main
- Léger et compact
- Version de sécurité
- Coupleurs pour moule
- Sans silicone

Applications

- Air comprimé
- Outillage pneumatique
- Agro alimentaire
- Sciences de la vie
- Système de refroidissement
- Gaz neutres, vide

ES

La gama de enchufes rápidos Aignep permite una respuesta adecuada a las múltiples necesidades de nuestros clientes. Las diferentes aplicaciones, las prestaciones y la fiabilidad, son las ventajas que ofrece esta importantísima gama.

A simple y doble obturación en latón niquelado, acero inox, conforme a las principales normas de referencia pueden ser utilizados para vehicular múltiples fluidos. Completan esta gama las pistolas de soplado.

Principales ventajas

- Pasos de DN 2,5 a 12 mm
- Perfiles normalizados
- Gama Multipresa
- Montaje con una sola mano
- Ligereza y reducidas dimensiones
- Versión de seguridad
- Refrigeración de moldes normalizados
- Libres de silicona

Aplicaciones

- Instalaciones de aire comprimido y herramientas
- Automatización neumática y fluidica
- Alimentos y bebidas
- Life & Science
- Refrigeración de moldes
- Gases inertes, versiones para vacío

PT

A linha de engates rápidos Aignep pode satisfazer as diferentes necessidades dos consumidores. Ampla gama: fechamento simples ou duplo, multisocket, segurança.

Os itens mais populares e diâmetros nominais estão disponíveis em latão niquelado ou aço inox.

A linha é adequada para ar comprimido e resfriamento de moldagem.

Completam a linha as pistolas de ar.

Principais Vantagens

- DN 2,5 - 12 mm
- Perfil-padrão
- Multisocket
- Instalação fácil - com uma só mão
- Leve e compacta
- Engate de Segurança
- Engates Resfriamento
- Livre de silicone

Aplicação

- Ar Comprimido & Ferramentas
- Pneumática & Tecnologia de Fluidos
- Alimentos e bebidas
- Life & Sciences
- Sistemas de Resfriamento
- Gases Inertes, Vácuo

SERIE 190 MULTISOCKET



Un'unica presa per 4 tipi di innesti **IT**

E' un dato di fatto che sul mercato esistono vari profili di innesti ben distinti sia nella forma che nelle dimensioni e generalmente necessitano di essere assemblati con specifiche prese che di norma non sono intercambiabili fra di loro.

Per poter ovviare a questa incompatibilità AIGNEP propone alla sua clientela una soluzione pratica ed economica, un'unica presa da utilizzare con 4 differenti tipi di profili garantendo per tutti una perfetta tenuta.

One socket for 4 different plugs **GB**

It is a matter of fact that on the market are available various types of plugs well distinguished whether on the shape or on the dimensions, usually they need to be assembled with specific sockets which normally are not interchangeable.

To get round to this incompatibility AIGNEP is proud to offer to its customers a practical and cost-effective solution, a unique socket to be used with 4 different types of plugs, ensuring a perfect tightening.

1 Kupplung Für 4 Typen Von Steckern **DE**

Es ist eine Tatsache, dass die auf dem Markt verfügbaren Kupplungen und Stecker mit verschiedenen, nicht kompatiblen Profilen in Form und Grösse geliefert werden, d.h. sie können nicht untereinander ausgetauscht montiert werden.

Um diese Austauschbarkeit zu ermöglichen, bietet AIGNEP seinen Kunden eine praktische und kostengünstige Lösung an, wo mit einer Kupplung 4 verschiedene Profile (Stecker) verwendet werden können und dennoch eine perfekte Abdichtung gewährleistet ist.

1 Corps pour 4 Embouts **FR**

Le marché met à disposition des utilisateurs des différents types de coupleurs qui varient selon les normes, la forme et les dimensions. Souvent il est nécessaire d'assembler plusieurs types de coupleurs qui ne sont pas interchangeables.

Pour contourner cette incompatibilité AIGNEP est fière d'offrir à ses clients une solution pratique, fiable et rentable où un corps unique pour être utilisé avec 4 embouts différents.

Un único enchufe para 4 tipos de adaptador **ES**

Es un dato a remarcar que en el mercado existen varios tipos de adaptadores distintos, ya sea en la forma como en las dimensiones, que generalmente necesitan de enchufes específicos no intercambiables entre ellos.

Para solucionar este problema AIGNEP, propone una solución práctica y económica de intercambiabilidad con todos los adaptadores homologados en el mercado europeo, garantizando para todos una perfecta estanqueidad.

Um único soquete p/ 4 tipos de plugs **PT**

É um fato que no mercado existem vários perfis de plug bem diferentes entre si, seja no seu formato ou com relação às suas medidas e que, por isto normalmente não são intercambiáveis, necessitando de um soquete específico para cada diferente tipo de plug.

Para fugir desta incompatibilidade de tipos de modelos a AIGNEP propõe a seus clientes uma solução prática e econômica: um único soquete para ser utilizado com 4 diferentes tipos de perfis, garantindo para todos uma vedação perfeita.

PROFIL SWISS
SERIE 270

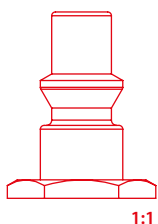

1:1

DN
5.5 mm

Pag. 15.45

PROFIL EUROPEAN
SERIE 260

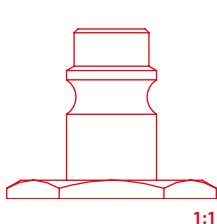

1:1

DN
7.5 - 7.8 mm

Pag. 15.39

PROFIL ITALIAN
SERIE 250

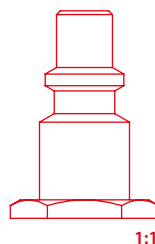

1:1

DN
5 mm

Pag. 15.23

PROFIL UNI ISO 6150 B-12
SERIE 220

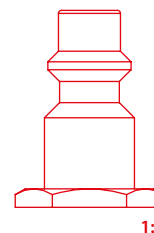

1:1

DN
5.5 mm

Pag. 15.17



CARATTERISTICHE TECNICHE
 TECHNICAL CHARACTERISTICS
 TECHNISCHE ANGABEN
 CARACTÉRISTIQUES TECHNIQUES
 CARACTERÍSTICAS TÉCNICAS
 CARACTERÍSTICAS TÉCNICAS



Norma di Riferimento
 Reference standard
 Entspricht der Norm
 Norme de référence
 Normativa de referencia
 Norma de referència

1907/2006 REACH ✓	2011/65/CE RoHS ✓
PED 2014/68/UE	SILICON FREE

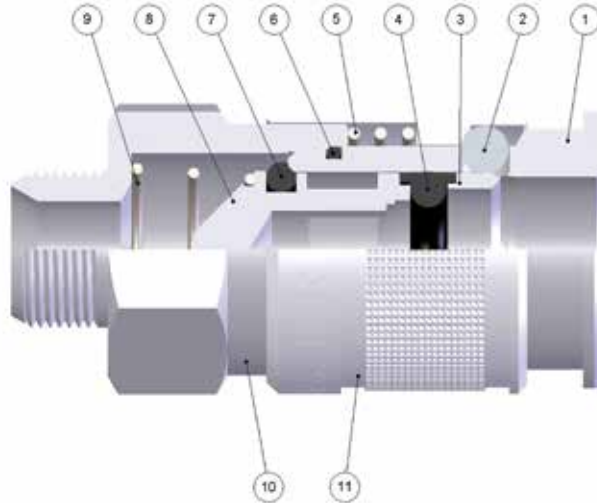

FKM A RICHIESTA
 IF REQUESTED FKM
 FKM AUF ANFRAGE
 FKM SUR DEMANDE
 FKM BAJO DEMANDA
 FKM SOB ENCOMENDA

Materiali e Componenti	IT	Component Parts and Materials	GB	Komponenten und Materialien	DE
1 Corpo in Ottone Nichelato		1 Nickel-Plated Brass Body		1 Körper Messing Vernickelt	
2 Sfera in Acciaio AISI 420		2 Stainless Steel AISI 420 Balls		2 Kugel Edelstahl AISI 420	
3 Anello Guida Innesto in Ottone Nichelato		3 Nickel-Plated Brass Guide Ring Coupling		3 Ring Aus Messing	
4 Guarnizione O-Ring in NBR		4 NBR O-Ring Seals		4 O-Ring NBR	
5 Molla Ghiera in Acciaio AISI 302		5 Stainless Steel AISI 302 Ring Nut Spring		5 Entriegelungsfeder Edelstahl AISI 302	
6 Guarnizione O-Ring in NBR		6 NBR O-Ring Seals		6 O-Ring NBR	
7 Guarnizione O-Ring in NBR		7 NBR O-Ring Seals		7 O-Ring NBR	
8 Otturatore in Ottone Nichelato		8 Nickel-Plated Brass Shutter		8 Verschluss Messing Vernickelt	
9 Molla Otturatore in Acciaio AISI 302		9 Stainless Steel AISI 302 Shutter Spring		9 Verschlussfeder Edelstahl AISI 302	
10 Attacco Terminale in Ottone Nichelato		10 Nickel-Plated Brass Coupling Back Part		10 Einschraubkörper Messing Vernickelt	
11 Ghiera in Ottone Nichelato		11 Nickel-Plated Brass Sleeve		11 Entriegelungshülse Messing Vernickelt	

Matériaux et Composants	FR	Materiales y Componentes	ES	Materialis e Componentes	PT
1 Corps: Laiton Nickelé		1 Cuerpo en latón niquelado		1 Corpo em latão niquelado	
2 Bille: Acier Inoxydable AISI 420		2 Esfera en acero AISI 420		2 Esfera em aço AISI 420	
3 Bague en Laiton		3 Anillo guía enchufe en latón niquelado		3 Anel guia do plug em latão niquelado	
4 Joint Torique en NBR		4 Junta tórica en NBR		4 Vedação O-Ring em NBR	
5 Ressort de Bague: Acier Inoxydable AISI 302		5 Muelle tuerca en acero AISI 302		5 Mola de porca em aço AISI 302	
6 Joint Torique en NBR		6 Junta tórica en NBR		6 Vedação O-Ring em NBR	
7 Joint Torique en NBR		7 Junta tórica en NBR		7 Vedação O-Ring em NBR	
8 Clapet en Laiton Nickelé		8 Obturador en latón niquelado		8 Obturador em latão niquelado	
9 Ressort de Clapet: Acier Inoxydable AISI 302		9 Muelle obturador en acero AISI 302		9 Mola do obturador em aço AISI 302	
10 Corps: Laiton Nickelé		10 Conexión terminal en latón niquelado		10 Conexão terminal em latão niquelado	
11 Bague: Laiton Nickelé		11 Tuerca en latón niquelado		11 Porca em latão niquelado	



Temperature
 Temperatures
 Temperatur
 Températures
 Temperaturas
 Temperaturas

- 20 °C
+ 80 °C

Con O-ring in FKM
 With FKM O-ring
 Mit O-ring in FKM
 Avec Joints en FKM
 Con Junta tórica en FKM
 Com O-ring em FKM

- 10 °C
+ 200 °C



Fluidi compatibili
 Aria compressa
 Fluids
 Compressed air
 Geeignete Medien
 Druckluft

Fluides compatibles
 Air comprimé

Fluidos compatibles
 Aire comprimido

Fluidos compatíveis
 Ar comprimido

Per altri fluidi, consultare l'ufficio tecnico Aignep.
 For other fluids, consult the technical department Aignep.
 Für andere Flüssigkeiten, kontaktieren Sie uns.
 Pour d'autres fluides, veuillez nous consulter.
 Para otros fluidos póngase en contacto con el departamento técnico Aignep.
 Para outros fluidos consulte o departamento técnico da Aignep.



Pressione d'esercizio

Working Pressures

Betriebsdruck

Pression de service

Presión de Ejercicio

Pressão de Trabalho

0 bar

16 bar



Max pressione statica (no pulsazioni)

Maximum static pressure (no pulsations)

Maximaler statischer Betriebsdruck (ohne pulsations)

Pression statique maximale (sans pulsation)

Presión estática máxima (sin pulsaciones)

Pressão estática máxima (sem pulsações)

35 bar



Portata

NI/min

Flow Rate

Durchflusswerte

Débit

Caudal de Flujo

Vazão

Innesto Plug Stecker Embout Adaptador Plug	6 bar Δ 1	6 bar Δ 0.5	6 bar Δ 0*
220	900	700	1450
250	800	700	1300
260 (7.5)	1350	1000	2150
260 (7.8)	1510	1200	2250
270	1100	750	1600

* Scarico libero - Exhaust Free - Kostenlose Auspuff - Échappement libre - Escape Libre - Descarga livree.



Filettatura

IT

Threads

GB

Gewindearten

DE

Gas cilindrica conforme ISO 228 Classe A.

Parallel gas in conformity with ISO 228 Class A.

Zylindrisches Gewinde nach Norm ISO 228 Classe A.

Filetages

FR

Roscas

ES

Roscas

PT

Filetage cylindrique conforme: ISO 228 Classe A.

Gas cilindrica conforme ISO 228 Clase A.

Gas paralela conforme ISO 228 Classe A.

191

PRESA MASCHIO

MALE SOCKET

VERSCHLUSS-KUPPLUNG MIT AUSSENGEWINDE

COUPLEUR MÂLE

ENCHUFE MACHO

SOQUETE COM ROSCA MACHO

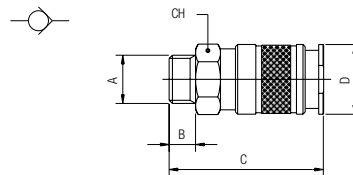

Code	A	B	C	D	CH	Pack.
00191 00 001	1/4	8	49	24	21	10
00191 00 002	3/8	9	50	24	21	10
00191 00 003	1/2	10	51	24	24	10

192

PRESA FEMMINA

FEMALE SOCKET

VERSCHLUSS-KUPPLUNG MIT INNENGEWINDE

COUPLEUR FEMELLE

ENCHUFE HEMBRA

SOQUETE COM ROSCA FÊMEA

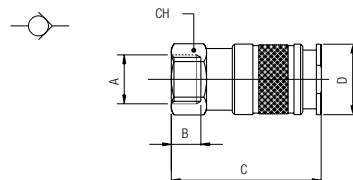

Code	A	B	C	D	CH	Pack.
00192 00 001	1/4	11	51	24	21	10
00192 00 002	3/8	11.5	51	24	21	10
00192 00 003	1/2	14	55	24	24	10

193

PRESA A CALZAMIENTO CON MOLLA

COMPRESSION SOCKET WITH SPRING
 VERSCHLUSS-KUPPLUNG MIT KNICKSCHUTZFEDER
 COUPLEUR AVEC RESSORT DE PROTECTION
 ENCHUFE TUBO CON MUELLE
 SOQUETE COM CONEXÃO PUSH-ON COM MOLA

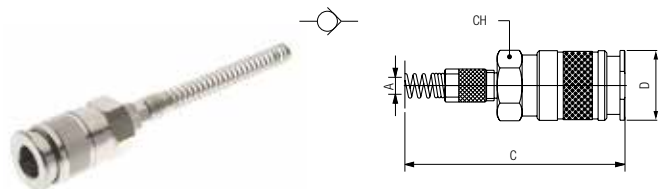

Code	A	B	C	D	CH	Pack.
00193 00 001	6/4	-	138	24	21	10
00193 00 002	8/6	-	144.5	24	21	10
00193 00 004	10/6.5	-	153.5	24	21	10
00193 00 003	10/8	-	153.5	24	21	10
00193 00 005	12/10	-	159	24	21	10

194

PRESA A CALZAMIENTO

COMPRESSION SOCKET
 VERSCHLUSS-KUPPLUNG MIT ÜBERWURFVERSCHRAUBUNG
 COUPLEUR RACCORD À COIFFE
 ENCHUFE TUBO
 SOQUETE COM CONEXÃO PUSH-ON

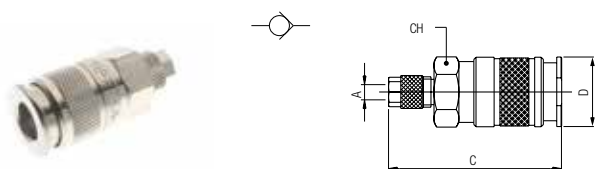

Code	A	B	C	D	CH	Pack.
00194 00 001	6/4	-	55	24	21	10
00194 00 002	8/6	-	55	24	21	10
00194 00 003	10/8	-	55	24	21	10
00194 00 007	12/10	-	57.5	24	21	10

195

PRESA CON PORTAGOMMA A RESCA

SOCKET WITH REST FOR RUBBER HOSE
 VERSCHLUSS-KUPPLUNG MIT SCHLAUCHTÜLLE
 COUPLEUR À DOUILLE ANNELÉE POUR TUBE
 ENCHUFE EPIGA
 SOQUETE COM EPIGÃO PARA MANGUEIRA DE BORRACHA

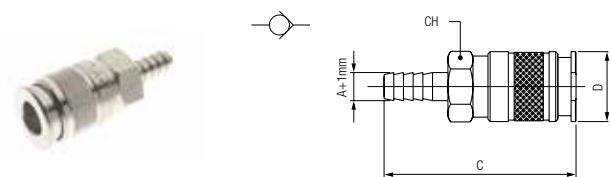

Code	A	B	C	D	CH	Pack.
00195 00 001	6	-	61	24	21	10
00195 00 002	8	-	61	24	21	10
00195 00 003	10	-	61	24	21	10
00195 00 004	12	-	61	24	21	10

196

PRESA CON PORTAGOMMA

SOCKET FOR RUBBER HOSE
 VERSCHLUSS-KUPPLUNG FÜR GUMMISCHLAUCH
 COUPLEUR À DOUILLE ANNELÉE POUR TUBE
 ENCHUFE COM PORTAGOMA
 SOQUETE COM EPIGÃO PARA TUBO DE BORRACHA

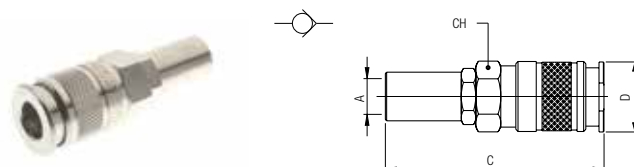

Code	A	B	C	D	CH	Pack.
00196 00 001	14/6	-	71	24	21	10
00196 00 002	17/8	-	71	24	21	10
00196 00 003	19/10	-	71	24	21	10

SERIE 120 UNI ISO 6150 B-12

DN
5.5 mm

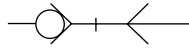

UNI ISO 6150 B-12

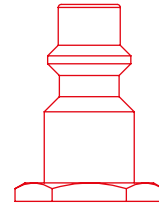

1:1

221

INNESTO MASCHIO

MALE PLUG
STECKER MIT AUSSENGEWINDE
EMBOUT MÂLE
ADAPTADOR MACHO
PLUG COM ROSCA MACHO

Code	A	B	C	D	CH	Pack.
00221 00 01 03 NB	1/4	8	36.5	-	17	10
00221 00 01 04 NB	3/8	9	37.5	-	19	10
00221 00 01 05 NB	1/2	10	39	-	24	10

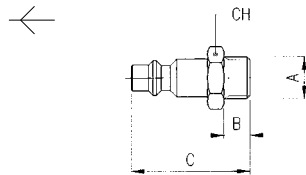

221AC

INNESTO IN ACCIAIO MASCHIO

STEEL MALE PLUG
STECKER MIT AUSSENGEWINDE AUS STAHL
EMBOUT MÂLE EN ACIER
ADAPTADOR EN ACERO MACHO
PLUG EM AÇO COM ROSCA MACHO

Code	A	B	C	D	CH	Pack.
221AC 00 51 03 ZI	1/4	8	36.5	-	17	10
221AC 00 51 04 ZI	3/8	9	37.5	-	19	10
221AC 00 51 05 ZI	1/2	10	39	-	24	10

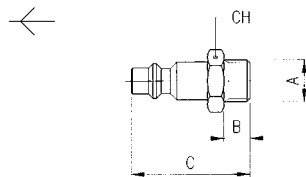

ACCIAIO INDURITO
HARDENED STEEL
GEHÄRTETEM STAHL
ACIER TREMPÉ
ACERO CURTIDO
AÇO ENDURECIDO

222

INNESTO FEMMINA

FEMALE PLUG
STECKER MIT INNENGEWINDE
EMBOUT FEMELLE
ADAPTADOR HEMBRA
PLUG COM ROSCA FÊMEA

Code	A	B	C	D	CH	Pack.
00222 00 01 03 NB	1/4	11	36.5	-	17	10
00222 00 01 04 NB	3/8	11.5	37	-	19	10
00222 00 01 05 NB	1/2	14	39.5	-	24	10

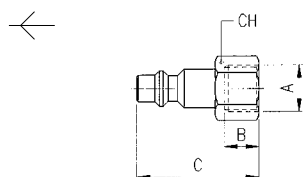

222AC

INNESTO IN ACCIAIO FEMMINA

STEEL FEMALE PLUG
 STECKER MIT INNENGEWINDE AUS STAHL
 EMBOUT FEMELLE EN ACIER
 ADAPTADOR EN ACERO HEMBRA
 PLUG EM AÇO COM ROSCA FÊMEA



Code	A	B	C	D	CH	Pack.
222AC 00 51 03 ZI	1/4	11	36.5	-	17	10
222AC 00 51 04 ZI	3/8	11.5	37	-	19	10
222AC 00 51 05 ZI	1/2	14	39.5	-	24	10

ACCIAIO INDURITO
 HARDENED STEEL
 GEHÄRTETEM STAHL
 ACIER TREMPÉ
 ACERO CURTIDO
 AÇO ENDURECIDO

223

INNESTO A CALZAMENTO CON MOLLA

COMPRESSION PLUG WITH SPRING
 STECKER MIT KNICKSCHUTZFEDER
 EMBOUT AVEC RESSORT DE PROTECTION
 ADAPTADOR TUBO CON MUELLE
 PLUG COM CONEXÃO PUSH-ON COM MOLA



Code	A	B	C	D	CH	Pack.
00223 00 001	6/4	-	123	-	13	10
00223 00 002	8/6	-	128.5	-	13	10
00223 00 003	10/8	-	136	-	14	10
00223 00 004	12/10	-	142	-	16	10

224

INNESTO A CALZAMENTO

COMPRESSION PLUG
 STECKER MIT ÜBERWURFVERSCHRÄUBUNG
 EMBOUT À RACCORD À COIFFE
 ADAPTADOR TUBO
 PLUG COM CONEXÃO PUSH-ON



Code	A	B	C	D	CH	Pack.
00224 00 001	6/4	-	41	-	13	10
00224 00 002	8/6	-	41	-	13	10
00224 00 003	10/8	-	43	-	14	10
00224 00 004	12/10	-	45	-	16	10

225

INNESTO CON PORTAGOMMA A RESCA

PLUG WITH REST FOR RUBBER HOSE
 STECKER MIT SCHLAUCHTÜLLE
 EMBOUT À DOUILLE ANNELÉE POUR TUBE
 ADAPTADOR ESPIGA
 PLUG COM ESPIGÃO PARA TUBO DE BORRACHA

Code	A	B	C	D	CH	Pack.
00225 00 01 X4 NB	6	-	43.5	12	-	10
00225 00 01 X7 NB	8	-	43.5	12	-	10
00225 00 01 X9 NB	10	-	46	14	-	10
00225 00 01 Y1 NB	12	-	46	16	-	10

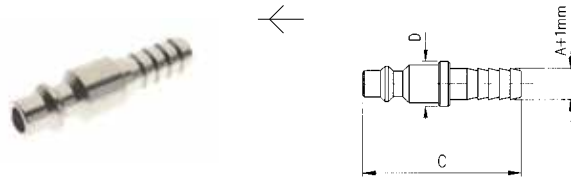

225AC

INNESTO IN ACCIAIO CON PORTAGOMMA A RESCA

STEEL PLUG WITH REST FOR RUBBER HOSE
 STECKER MIT SCHLAUCHTÜLLE AUS STAHL
 EMBOUT À DOUILLE ANNELÉE POUR TUBE EN ACIER
 ADAPTADOR EN ACERO ESPIGA
 PLUG EM AÇO COM ESPIGÃO PARA TUBO DE BORRACHA

Code	A	B	C	D	CH	Pack.
225AC 00 51 X4 ZI	6	-	43.5	12	-	10
225AC 00 51 X7 ZI	8	-	43.5	12	-	10
225AC 00 51 X9 ZI	10	-	46	14	-	10
225AC 00 51 Y1 ZI	12	-	46	16	-	10

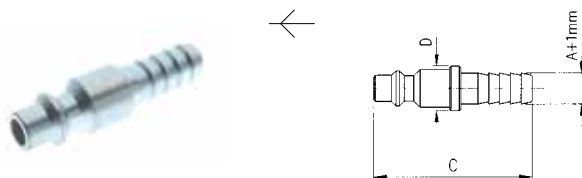

ACCIAIO INDURITO
 HARDENED STEEL
 GEHÄRTETEM STAHL
 ACIER TREMPÉ
 ACERO CURTIDO
 AÇO ENDURECIDO

227

INNESTO A BAIONETTA

BAYONET PLUG
 STECKER MIT BAJONETT-VERSCHLUSS
 EMBOUT À RACCORD À BAIONNETTE
 ADAPTADOR BAYONETA
 PLUG COM CONEXÃO TIPO BAIONETA

Code	A	B	C	D	CH	Pack.
00227 00 001	15	-	37	-	15	10

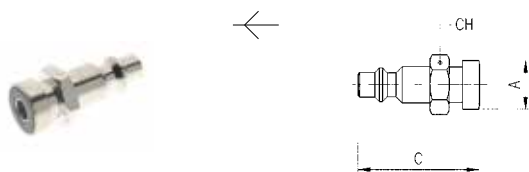

228

INNESTO A SCARICO PROGRESSIVO

PLUG WITH GRADUAL EXHAUST
 STECKER MIT PROGRESSIVER ENTLASTUNG
 EMBOUT À PASSAGE PROGRESSIF
 ADAPTADOR DE DESCARGA PROGRESIVA
 PLUG COM ESCAPE PROGRESSIVO

Code	A	B	C	CH	Pack.
00228 00 001	1/4	11	45	17	10

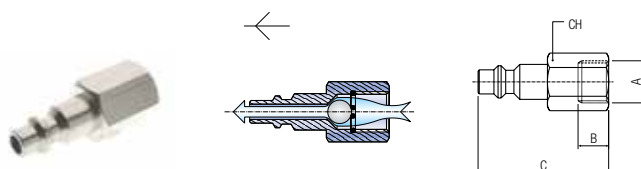

SERIE 120 ITALIAN PROFILE

DN
5 mm

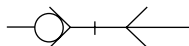

ITALIAN

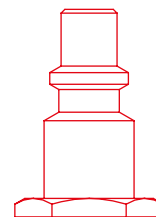

1:1

251
INNESTO MASCHIO

MALE PLUG
 STECKER MIT AUSSENGEWINDE
 EMBOUT MÂLE
 ADAPTADOR MACHO
 PLUG COM ROSCA MACHO

Code	A	B	C	D	CH	Pack.
00251 00 01 03 NB	1/4	8	38	-	17	10
00251 00 01 04 NB	3/8	9	39	-	19	10
00251 00 01 05 NB	1/2	10	40.5	-	24	10

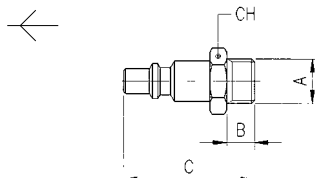
251AC
INNESTO IN ACCIAIO MASCHIO

STEEL MALE PLUG
 STECKER MIT AUSSENGEWINDE AUS STAHL
 EMBOUT MÂLE EN ACIER
 ADAPTADOR EN ACERO MACHO
 PLUG EM AÇO COM ROSCA MACHO

Code	A	B	C	D	CH	Pack.
251AC 00 51 03 ZI	1/4	8	38	-	17	10
251AC 00 51 04 ZI	3/8	9	39	-	19	10
251AC 00 51 05 ZI	1/2	10	40.5	-	24	10

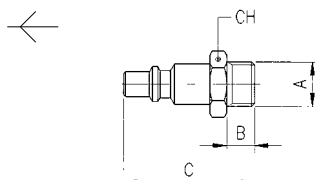

ACCIAIO INDURITO
 HARDENED STEEL
 GEHÄRTETEM STAHL
 ACIER TREMPÉ
 ACERO CURTIDO
 AÇO ENDURECIDO

252
INNESTO FEMMINA

FEMALE PLUG
 STECKER MIT INNENGEWINDE
 EMBOUT FEMELLE
 ADAPTADOR HEMBRA
 PLUG COM ROSCA FÊMEA

Code	A	B	C	D	CH	Pack.
00252 00 01 03 NB	1/4	11	38	-	17	10
00252 00 01 04 NB	3/8	11.5	38.5	-	19	10
00252 00 01 05 NB	1/2	14	41	-	24	10

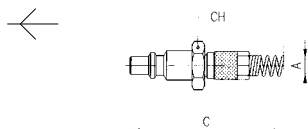

252AC

INNESTO IN ACCIAIO FEMMINA

STEEL FEMALE PLUG

STECKER MIT INNENGEWINDE AUS STAHL

EMBOUT FEMELLE EN ACIER

ADAPTADOR EN ACERO HEMBRA

PLUG EM AÇO COM ROSCA FÊMEA

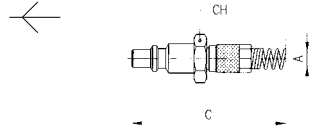

Code	A	B	C	D	CH	Pack.
252AC 00 51 03 ZI	1/4	11	38	-	17	10
252AC 00 51 04 ZI	3/8	11.5	38.5	-	19	10
252AC 00 51 05 ZI	1/2	14	41	-	24	10

ACCIAIO INDURITO
HARDENED STEEL
GEHÄRTETEM STAHL
ACIER TREMPÉ
ACERO CURTIDO
AÇO ENDURECIDO

253

INNESTO A CALZAMENTO CON MOLLA

COMPRESSION PLUG WITH SPRING

STECKER MIT KNICKSCHUTZFEDER

EMBOUT AVEC RESSORT DE PROTECTION

ADAPTADOR TUBO CON MUELLE

PLUG COM CONEXÃO PUSH-ON COM MOLA

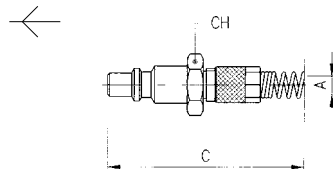

Code	A	B	C	D	CH	Pack.
00253 00 001	6/4	-	124.5	-	13	10
00253 00 002	8/6	-	130	-	13	10
00253 00 003	10/8	-	137.5	-	14	10
00253 00 004	12/10	-	143	-	16	10

254

INNESTO A CALZAMENTO

COMPRESSION PLUG

STECKER MIT ÜBERWURFVERSCHRÄUBUNG

EMBOUT À RACCORD À COIFFE

ADAPTADOR TUBO

PLUG COM CONEXÃO PUSH-ON

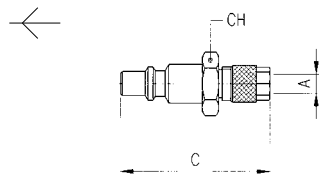

Code	A	B	C	D	CH	Pack.
00254 00 001	6/4	-	43.5	-	13	10
00254 00 002	8/6	-	43.5	-	13	10
00254 00 003	10/8	-	44.5	-	14	10
00254 00 004	12/10	-	46	-	16	10

255

INNESTO CON PORTAGOMMA A RESCA

PLUG WITH REST FOR RUBBER HOSE
 STECKER MIT SCHLAUCHTÜLLE
 EMBOUT À DOUILLE ANNELÉE POUR TUBE
 ADAPTADOR ESPIGA
 PLUG COM ESPIGÃO PARA TUBO DE BORRACHA



Code	A	B	C	D	CH	Pack.
00255 00 01 X4 NB	6	-	44.5	12	-	10
00255 00 01 X7 NB	8	-	44.5	12	-	10
00255 00 01 X9 NB	10	-	47.5	14	-	10
00255 00 01 Y1 NB	12	-	47.5	16	-	10

255AC

INNESTO IN ACCIAIO CON PORTAGOMMA A RESCA

STEEL PLUG WITH REST FOR RUBBER HOSE
 STECKER MIT SCHLAUCHTÜLLE AUS STAHL
 EMBOUT À DOUILLE ANNELÉE POUR TUBE EN ACIER
 ADAPTADOR EN ACERO ESPIGA
 PLUG EM AÇOÙ COM ESPIGÃO PARA TUBO DE BORRACHA



Code	A	B	C	D	CH	Pack.
255AC 00 51 X4 ZI	6	-	44.5	12	-	10
255AC 00 51 X7 ZI	8	-	44.5	12	-	10
255AC 00 51 X9 ZI	10	-	47.5	14	-	10
255AC 00 51 Y1 ZI	12	-	47.5	16	-	10

ACCIAIO INDURITO
 HARDENED STEEL
 GEHÄRTETEM STAHL
 ACIER TREMPÉ
 ACERO CURTIDO
 AÇO ENDURECIDO

256

INNESTO CON PORTAGOMMA

PLUG FOR RUBBER HOSE
 STECKER FÜR GUMMISCHLAUCH
 EMBOUT POUR TUBE
 ADAPTADOR CON PORTAGOMA
 PLUG COM ESPIGÃO PARA TUBO DE BORRACHA

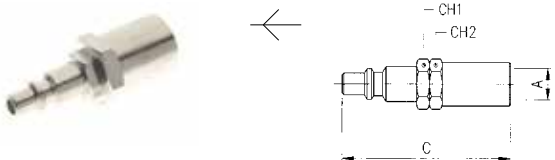

Code	A	B	C	CH1	CH2	Pack.
00256 00 001	14/6	-	60	15	17	10
00256 00 002	17/8	-	60	15	20	10
00256 00 003	19/10	-	60	15	22	10

257

INNESTO A BAIONETTA

BAYONET PLUG
 STECKER MIT BAJONETT-VERSCHLUSS
 EMBOUT À RACCORD À BAIONNETTE
 ADAPTADOR BAYONETA
 PLUG COM CONEXÃO TIPO BAIONETA

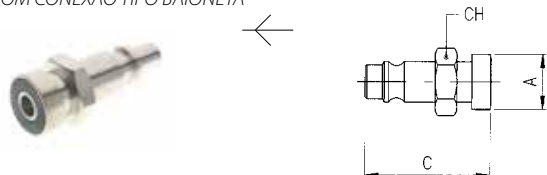

Code	A	B	C	D	CH	Pack.
00257 00 001	15	-	38.5	-	15	10

258

INNESTO A SCARICO PROGRESSIVO

PLUG WITH GRADUAL EXHAUST
 STECKER MIT PROGRESSIVER ENTLASTUNG
 EMBOUT À PASSAGE PROGRESSIF
 ADAPTADOR DE DESCARGA PROGRESIVA
 PLUG COM ESCAPE PROGRESSIVO

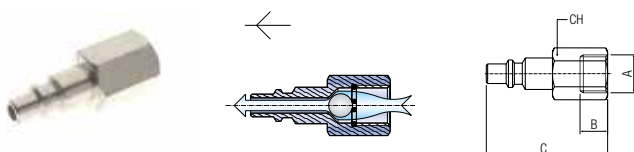

Code	A	B	C	CH	Pack.
00258 00 001	1/4	11	46.5	17	10

SERIE 160 EUROPEAN PROFILE

DN
7.5 - 7.8 mm

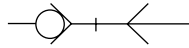

EUROPEAN

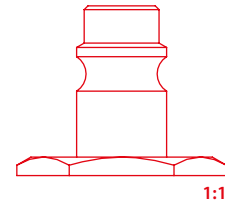

261

INNESTO MASCHIO

MALE PLUG
STECKER MIT AUSSENGEWINDE
EMBOUT MÂLE
ADAPTADOR MACHO
PLUG COM ROSCA MACHO

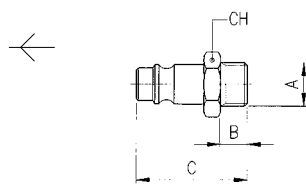

Code	A	B	C	D	CH	Pack.
00261 00 01 03 NB	1/4	8	33	-	17	10
00261 00 01 04 NB	3/8	9	34	-	19	10
00261 00 01 05 NB	1/2	10	35.5	-	24	10

261AC DN 7.8

INNESTO IN ACCIAIO MASCHIO

STEEL MALE PLUG
STECKER MIT AUSSENGEWINDE AUS STAHL
EMBOUT MÂLE EN ACIER
ADAPTADOR EN ACERO MACHO
PLUG EM AÇO COM ROSCA MACHO

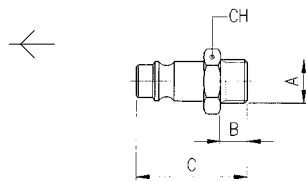

Code	A	B	C	D	CH	Pack.
261AC 00 51 03 ZI	1/4	8	33	-	17	10
261AC 00 51 04 ZI	3/8	9	34	-	19	10
261AC 00 51 05 ZI	1/2	10	35.5	-	24	10

ACCIAIO INDURITO
HARDENED STEEL
GEHÄRTETEM STAHL
ACIER TREMPÉ
ACERO CURTIDO
AÇO ENDURECIDO

262

INNESTO FEMMINA

FEMALE PLUG
STECKER MIT INNENGEWINDE
EMBOUT FEMELLE
ADAPTADOR HEMBRA
PLUG COM ROSCA FÊMEA

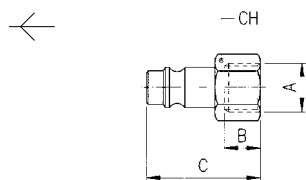

Code	A	B	C	D	CH	Pack.
00262 00 01 03 NB	1/4	11	33	-	17	10
00262 00 01 04 NB	3/8	11.5	33.5	-	19	10
00262 00 01 05 NB	1/2	14	36	-	24	10

262AC DN 7.8

INNESTO IN ACCIAIO FEMMINA

STEEL FEMALE PLUG

STECKER MIT INNENGEWINDE AUS STAHL

EMBOUT FEMELLE EN ACIER

ADAPTADOR EN ACERO HEMBRA

PLUG EM AÇO COM ROSCA FÊMEA

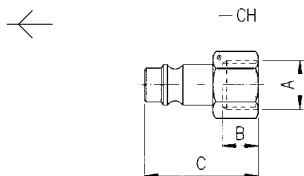

Code	A	B	C	D	CH	Pack.
262AC 00 51 03 ZI	1/4	11	33	-	17	10
262AC 00 51 04 ZI	3/8	11.5	33.5	-	19	10
262AC 00 51 05 ZI	1/2	14	36	-	24	10

ACCIAIO INDURITO
HARDENED STEEL
GEHÄRTETEM STAHL
ACIER TREMPÉ
ACERO CURTIDO
AÇO ENDURECIDO

263

INNESTO A CALZAMENTO CON MOLLA

COMPRESSION PLUG WITH SPRING

STECKER MIT KNICKSCHUTZFEDER

EMBOUT AVEC RESSORT DE PROTECTION

ADAPTADOR TUBO CON MUELLE

PLUG COM CONEXÃO PUSH-ON COM MOLA

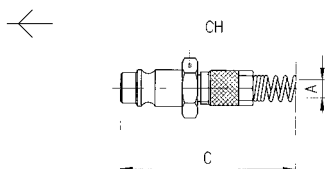

Code	A	B	C	D	CH	Pack.
00263 00 001	6/4	-	124.5	-	13	10
00263 00 002	8/6	-	130	-	13	10
00263 00 003	10/8	-	137.5	-	14	10
00263 00 004	12/10	-	143	-	16	10

264

INNESTO A CALZAMENTO

COMPRESSION PLUG

STECKER MIT ÜBERWURFVERSCHRAUBUNG

EMBOUT À RACCORD À COIFFE

ADAPTADOR TUBO

PLUG COM CONEXÃO PUSH-ON

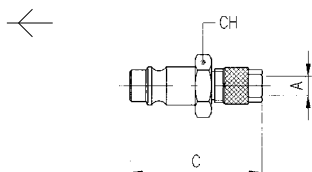

Code	A	B	C	D	CH	Pack.
00264 00 001	6/4	-	36	-	13	10
00264 00 002	8/6	-	36.5	-	13	10
00264 00 003	10/8	-	38.5	-	14	10
00264 00 004	12/10	-	47.5	-	16	10

265

INNESTO CON PORTAGOMMA A RESCA

PLUG WITH REST FOR RUBBER HOSE

STECKER MIT SCHLAUCHTÜLLE

EMBOUT À DOUILLE ANNELÉE POUR TUBE

ADAPTADOR ESPIGA

PLUG COM ESPIGÃO PARA TUBO DE BORRACHA

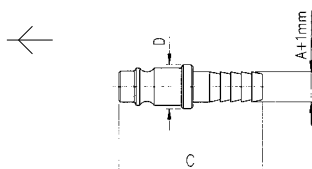

Code	A	B	C	D	CH	Pack.
00265 00 01 X4 NB	6	-	39.5	12	-	10
00265 00 01 X7 NB	8	-	39.5	12	-	10
00265 00 01 X9 NB	10	-	42.5	14	-	10
00265 00 01 Y1 NB	12	-	42.5	16	-	10

265AC DN 7.8

INNESTO IN ACCIAIO CON PORTAGOMMA A RESCA

STEEL PLUG WITH REST FOR RUBBER HOSE

STECKER MIT SCHLAUCHTÜLLE AUS STAHL

EMBOUT À DOUILLE ANNELÉE POUR TUBE EN ACIER

ADAPTADOR EN ACERO ESPIGA

PLUG EM AÇO COM ESPIGÃO PARA TUBO DE BORRACHA

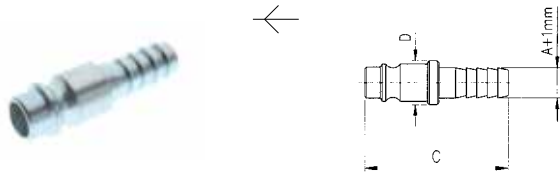

Code	A	B	C	D	CH	Pack.
265AC 00 51 X4 ZI	6	-	39.5	12	-	10
265AC 00 51 X7 ZI	8	-	39.5	12	-	10
265AC 00 51 X9 ZI	10	-	42.5	14	-	10
265AC 00 51 Y1 ZI	12	-	42.5	16	-	10

ACCIAIO INDURITO
HARDENED STEEL
GEHÄRTETEM STAHL
ACIER TREMPÉ
ACERO CURTIDO
AÇO ENDURECIDO

266

INNESTO CON PORTAGOMMA

PLUG FOR RUBBER HOSE

STECKER FÜR GUMMISCHLAUCH

EMBOUT POUR TUBE

ADAPTADOR CON PORTAGOMA

PLUG COM ESPIGÃO PARA TUBO DE BORRACHA

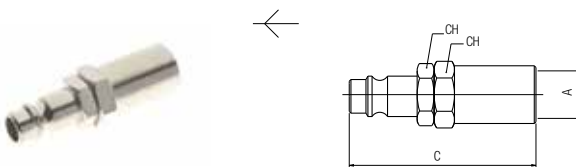

Code	A	B	C	CH1	CH2	Pack.
00266 00 001	14/6	-	55	15	17	10
00266 00 002	17/8	-	55	15	20	10
00266 00 003	19/10	-	55	15	22	10

267

INNESTO A BAIONETTA

BAYONET PLUG

STECKER MIT BAJONETT-VERSCHLUSS

EMBOUT À BAIONNETTE

ADAPTADOR BAYONETA

PLUG COM CONEXÃO TIPO BAIONETA

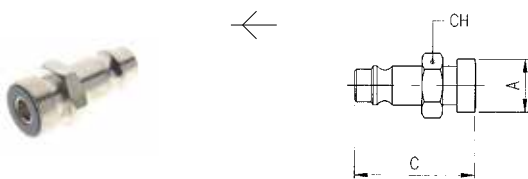

Code	A	B	C	D	CH	Pack.
00267 00 001	15	-	33.5	-	15	10

268

INNESTO A SCARICO PROGRESSIVO

PLUG WITH GRADUAL EXHAUST

STECKER MIT PROGRESSIVER ENTLASTUNG

EMBOUT À PASSAGE PROGRESSIF

ADAPTADOR DE DESCARGA PROGRESIVA

PLUG COM ESCAPE PROGRESSIVO

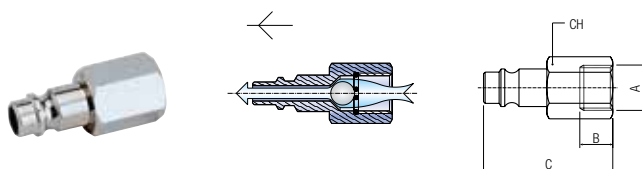

Code	A	B	C	CH	Pack.
00268 00 001	1/4	11	41.5	17	10

SERIE 170 SWISS PROFILE

 DN

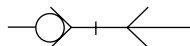
 5.5 mm

SWISS

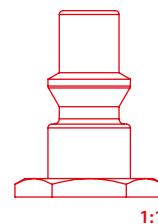
271
INNESTO MASCHIO

MALE PLUG
 STECKER MIT AUSSENGEWINDE
 EMBOUT MÂLE
 ADAPTADOR MACHO
 PLUG COM ROSCA MACHO

Code	A	B	C	D	CH	Pack.
00271 00 01 03 NB	1/4	8	36	-	17	10
00271 00 01 04 NB	3/8	9	37	-	19	10
00271 00 01 05 NB	1/2	10	38.5	-	24	10

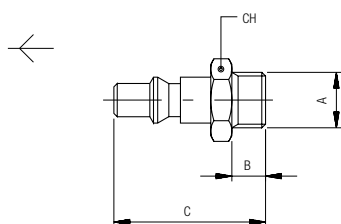
271AC
INNESTO IN ACCIAIO MASCHIO

STEEL MALE PLUG
 STECKER MIT AUSSENGEWINDE AUS STAHL
 EMBOUT MÂLE EN ACIER
 ADAPTADOR EN ACERO MACHO
 PLUG EM AÇO COM ROSCA MACHO

Code	A	B	C	D	CH	Pack.
271AC 00 51 03 ZI	1/4	8	36	-	17	10
271AC 00 51 04 ZI	3/8	9	37	-	19	10
271AC 00 51 05 ZI	1/2	10	38.5	-	24	10

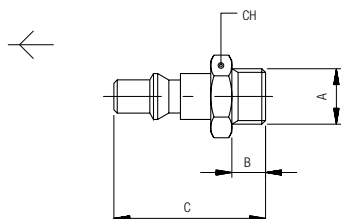

ACCIAIO INDURITO
 HARDENED STEEL
 GEHÄRTETEM STAHL
 ACIER TREMPÉ
 ACERO CURTIDO
 AÇO ENDURECIDO

272
INNESTO FEMMINA

FEMALE PLUG
 STECKER MIT INNENGEWINDE
 EMBOUT FEMELLE
 ADAPTADOR HEMBRA
 PLUG COM ROSCA FÊMEA

Code	A	B	C	D	CH	Pack.
00272 00 01 03 NB	1/4	11	36	-	17	10
00272 00 01 04 NB	3/8	11.5	36.5	-	19	10
00272 00 01 05 NB	1/2	14	39	-	24	10

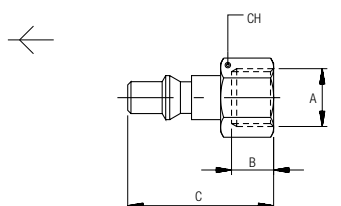

272AC

INNESTO IN ACCIAIO FEMMINA

STEEL FEMALE PLUG
 STECKER MIT INNENGEWINDE AUS STAHL
 EMBOUT FEMELLE EN ACIER
 ADAPTADOR EN ACERO HEMBRA
 PLUG EM AÇO COM ROSCA FÊMEA

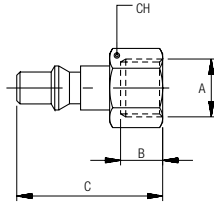

Code	A	B	C	D	CH	Pack.
272AC 00 51 03 ZI	1/4	11	36	-	17	10
272AC 00 51 04 ZI	3/8	11.5	36.5	-	19	10
272AC 00 51 05 ZI	1/2	14	39	-	24	10

ACCIAIO INDURITO
 HARDENED STEEL
 GEHÄRTETEM STAHL
 ACIER TREMPÉ
 ACERO CURTIDO
 AÇO ENDURECIDO

273

INNESTO A CALZAMENTO CON MOLLA

COMPRESSION PLUG WITH SPRINGS
 STECKER MIT KNICKSCHUTZFEDER
 EMBOUT AVEC RESSORT DE PROTECTION
 ADAPTADOR TUBO CON MUELLE
 PLUG COM CONEXÃO PUSH-ON COM MOLA

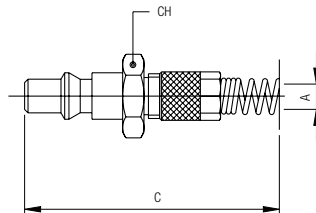

Code	A	B	C	D	CH	Pack.
00273 00 001	6/4	-	122.5	-	13	10
00273 00 002	8/6	-	128	-	13	10
00273 00 003	10/8	-	135.5	-	14	10
00273 00 004	12/10	-	146	-	16	10

274

INNESTO A CALZAMENTO

COMPRESSION PLUG
 STECKER MIT ÜBERWURFVERSCHRÄUBUNG
 EMBOUT À RACCORD À COIFFE
 ADAPTADOR TUBO
 PLUG COM CONEXÃO PUSH-ON

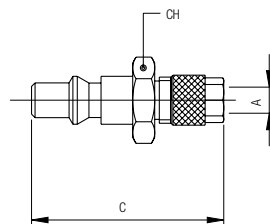

Code	A	B	C	D	CH	Pack.
00274 00 001	6/4	-	41.5	-	13	10
00274 00 002	8/6	-	41.5	-	13	10
00274 00 003	10/8	-	42.5	-	14	10
00274 00 004	12/10	-	44.5	-	16	10

275

INNESTO CON PORTAGOMMA A RESCA

PLUG WITH REST FOR RUBBER HOSE
 STECKER MIT SCHLAUCHTÜLLE
 EMBOUT À DOUILLE ANNELÉE POUR TUBE
 ADAPTADOR ESPIGA
 PLUG COM ESPIGÃO PARA TUBO DE BORRACHA

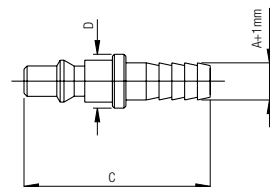

Code	A	B	C	D	CH	Pack.
00275 00 01 X4 NB	6	-	42.5	11	-	10
00275 00 01 X7 NB	8	-	42.5	11	-	10
00275 00 01 X9 NB	10	-	45.5	14	-	10
00275 00 01 Y1 NB	12	-	45.5	16	-	10

275AC

INNESTO IN ACCIAIO CON PORTAGOMMA A RESCA

STEEL PLUG WITH REST FOR RUBBER HOSE

STECKER MIT SCHLAUCHTÜLLE AUS STAHL

EMBOUT À DOUILLE ANNELÉE POUR TUBE EN ACIER

ADAPTADOR EN ACERO ESPIGA

PLUG EM AÇO COM ESPIGÃO PARA TUBO DE BORRACHA

Code	A	B	C	D	CH	Pack.
275AC 00 51 X4 ZI	6	-	42.5	11	-	10
275AC 00 51 X7 ZI	8	-	42.5	11	-	10
275AC 00 51 X9 ZI	10	-	45.5	14	-	10
275AC 00 51 Y1 ZI	12	-	45.5	16	-	10

ACCIAIO INDURITO
HARDENED STEEL
GEHÄRTETEM STAHL
ACIER TREMPÉ
ACERO CURTIDO
AÇO ENDURECIDO

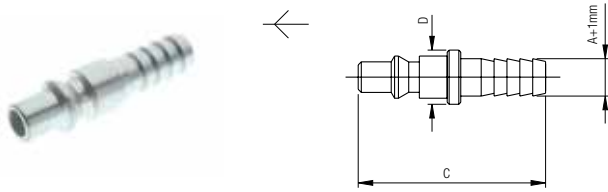

277

INNESTO A BAIONETTA

BAYONET PLUG

STECKER MIT BAJONETT-VERSCHLUSS

EMBOUT À RACCORD À BAIONNETTE

ADAPTADOR BAYONETA

PLUG COM CONEXÃO TIPO BAIONETA

Code	A	B	C	D	CH	Pack.
00277 00 001	15	-	36.5	-	15	10

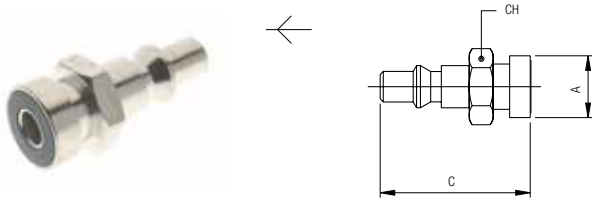

278

INNESTO A SCARICO PROGRESSIVO

PLUG WITH GRADUAL EXHAUST

STECKER MIT PROGRESSIVER ENTLASTUNG

EMBOUT À PASSAGE PROGRESSIF

ADAPTADOR DE DESCARGA PROGRESIVA

PLUG COM ESCAPE PROGRESSIVO

Code	A	B	C	CH	Pack.
00278 00 001	1/4	11	44.5	17	10

