

General points

The stair-nosing is a colored strip with thin and close grooves. The tread has wide and spaced out grooves.

The stair-nosing should have a minimum 12 cm radius rounded form. It should not have an overhanging lipping (bird's beak). The rounded form should be completely straight and regular.

The steps should be level and the treads horizontally aligned.

In a roll width, you can make two regular steps.

As the treads are opposite, the roll width can cover with the same cutting:

- till 32 cm deep fliers,
- from 0 to 55 cm deep balanced steps.

The minimal temperature of the premises and subfloor is at least 10°C.

Preparation

The surfaces must be flat, sound, smooth, clean and permanently dry.

The nose radius of the step must be greater than 12mm.

Skim the tread and riser of each step thoroughly with a stopper compound as laid down in the specifications.

Preparing and cutting the first and last Sarlon Complete Step (contrast)

- Pre-cut the riser part to ensure at least 100mm of contrast will be visible against the rest of the step covering
- Cut out the same shape in the contrasting material, using the original off-cut as a pattern
- Hot weld the two pieces of covering before fitting the step covering, ensuring that it is flat.

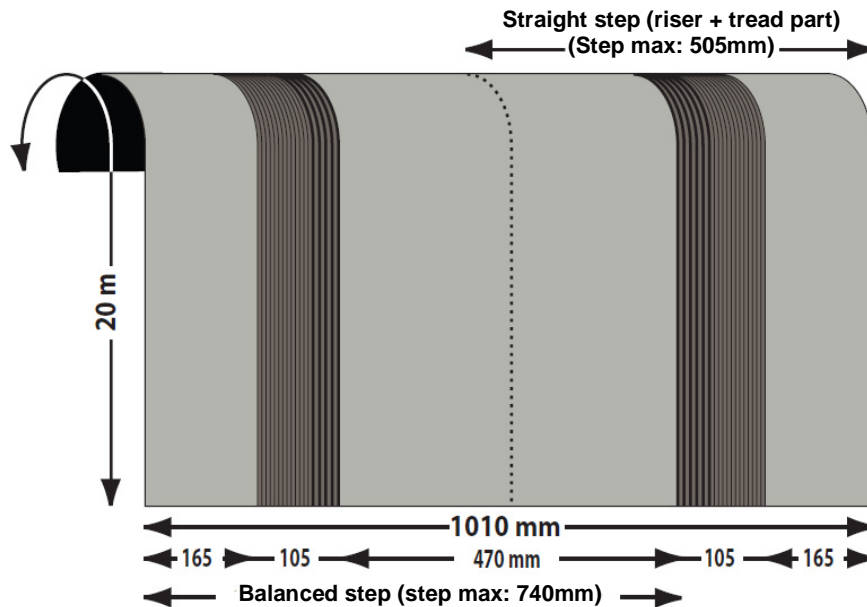

Glue-spreading

- Before the glue-spreading, sweep up and Hoover up the surfaces to glue (subfloor and floor covering back).
- Make a double spreading (subfloor and complete step) using a contact adhesive such as PU M25 in order to prevent any adhesive or subfloor moving.

Adhesive : Refer to the adhesive recommended by the manufacturer : PU M25 by Forbo Sarlino and respect the quantity: 300g/m² double spreading (150g on the subfloor and 150g on the backing of the floor covering) with a notched trowel or a brush.

Open time: around 10 minutes. The adhesive will not stick to the fingers anymore.

Neoprene adhesives are not allowed for Sarlon Complete Step installation because of high risk of migration of polychloroprene component through layers of the vinyl floorcovering.

Installing the first and last step

The first and last step coverings must have a riser with a minimum depth of 100mm that contrasts visibly with the rest of the step covering.

Step nosing's must meet the following requirements:

- Visible contrast with the rest of the staircase
- Non-slip
- No excessive overhang above the riser.

Installing the Sarlon Complete Step

- Start laying the covering from the foot of the stairs.
- Identify the rib in the step coverings that will be positioned at the start of the nosing radius and mark it with a chalked string line on the back of the covering (Line A below).

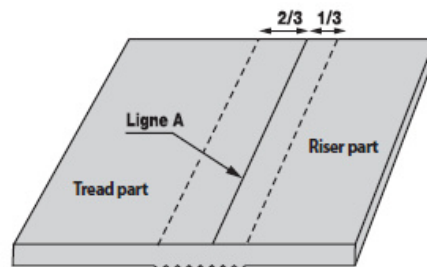

- Using a smooth spatula, apply contact adhesive to the back of the step covering and the step surface in a quantity of 150g/m² per face as explained before.
- After observing the tack time, roll the step covering into position, first aligning the nosing and then rolling it out whilst checking that the nosing guideline remains properly aligned.

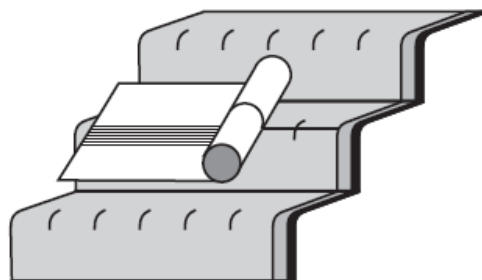

- Press down firmly and in the following order:

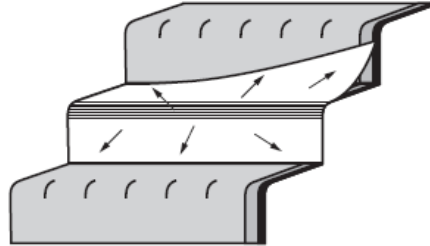

1. The ribs on the tread part, pressing longitudinally
2. The tread part, from the centre to the edges
3. The rounded part of the ribs, from the riser edge downwards
4. The riser itself, from the centre to the edges
5. Trim the step covering in the flat angles of the tread/riser against the side strips.

Seams

Wait 24 hours to make a cold welding on step bottom. You can make a hot welding using a 4 mm welding rod. Make a hand groove using a grooving gouge. Then, cut with a diameter 6 cutting gouge.

The landing tread jointing with the landing sheet is hot welded. In case of a thickness difference between the two materials, cut using a flat blade cutting gouge.

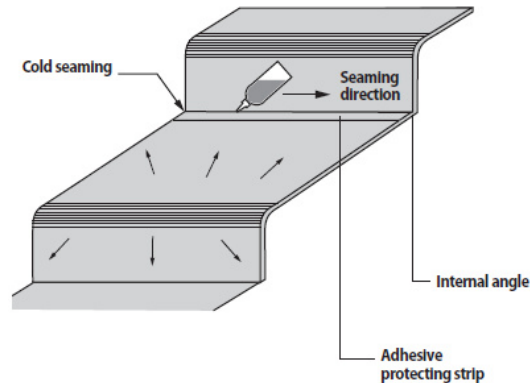

Before opening

24 hours after the installation

Maintenance

Cleaning at least 48 hours after the end of the works.